

*US CUSTOMARY UNITS*

**D262100**

**F.A. PROJECT**

---

# **PROPOSAL**

---

**Proposal Description:**

Replacement of (2) I-84 Bridges (precast concrete) over Dingle Ridge Road in the Town of Southeast

**Letting of 11/1/2012 @ 10:30 A.M.**

Submitted in accordance with Standard Specifications officially adopted May 1, 2008 and the Highway Law.

## **Book 3 of 3**



Blank Page



## SECTION 649 - AUDIBLE ROADWAY DELINEATORS

Make the following changes to the Standard Specifications of May 1, 2008:

**Delete** Section 649 (VACANT) and **replace** with the following:

## SECTION 649 – AUDIBLE ROADWAY DELINEATORS

**649-1 DESCRIPTION.** Audible delineators are depressions placed on the road surface to serve as driving aids. This work shall consist of installing audible roadway delineators where indicated on the contract documents.

**649-2 MATERIALS.** None specified.

## 649-3 CONSTRUCTION DETAILS

**Milled-In Audible Roadway Delineators (MIARDs).**

**A. Equipment.** The construction equipment shall include a rotary type cutting head capable of cutting the MIARD depressions to the dimensions and at the spacing indicated on the Standard Sheets. The pattern of cutting tips on the head shall be arranged to produce a relatively smooth cut with approximately 1/16 inch between peaks and valleys. Prior to beginning full production work on asphalt shoulders, the Contractor shall demonstrate to the Engineer the ability to achieve the desired surface without tearing or snagging the asphalt to be milled.

The cutting head shall be on its own suspension system, independent from that of the power unit, to allow the head to align itself with the slope of the shoulder and/or any irregularities in the shoulder surface. The cutting tool shall be equipped with guides or a guidance system, clearly visible to the operator, to provide for consistent alignment of each MIARD at the offsets from traveled way indicated on the project plans. Where directed by the Plans or EIC to mill in MIARDs in areas marked with crosshatching, the spacing of the MIARDs shall be adjusted to minimize damage to the markings. No milling shall be done within 4 inches of transverse joints.

**B. Installation and Dimensions.** The finished MIARDs shall conform to the dimensions and spacing shown on the Standard Sheets. The milling machine shall be capable of grinding to within 3 feet of an obstruction. The offset from traveled way may be changed at the EIC's discretion.

At the end of each working day, the Contractor shall remove all equipment to a location where it does not present a hazard to traffic. The pavement shall be cleaned by sweeping and the work area shall be reopened to traffic. The milled material shall be thoroughly removed from the shoulders. In uncurbed areas, the millings may be swept off the shoulder to serve as shoulder back-up material. In curbed areas, millings shall be removed from the project and disposed of in an acceptable manner.

**Centerline Audible Roadway Delineators (CARDs).**

**A. Scheduling and Coordination.** Because of the need to promptly replace pavement markings and reopen the highway to traffic, milling of CARDs shall not be conducted when conditions would not allow pavement markings to be placed soon after. To facilitate prompt placement of pavement markings by either the Department's pavement marking crews or the Contractor as indicated in the contract documents, all work shall be done between April 1 and November 30 Downstate (in the counties of Dutchess, Orange, Rockland, Putnam, Westchester, Nassau, Suffolk, and the City of New York) and between May 1 and October 31 Upstate (all other counties). If the contract documents indicate that pavement markings will be installed by the Department, the Contractor shall inform the Engineer of the planned work schedule and the Engineer will coordinate with the Department's pavement marking crew chief. If the contract documents indicate that pavement markings will be installed by the Contractor, pavement markings shall be installed

**SECTION 649 - AUDIBLE ROADWAY DELINEATORS**

within three calendar days, measuring from the date on which the markings at that point were first removed.

Gaps: Prior to milling, the Contractor shall obtain EIC approval on where CARDS are to be installed and where gaps are to be included.

**B. Timing of CARD Placements.** New asphalt pavement should be allowed to harden for at least 24 hours before CARDS are milled in, so that the milling machine does not tear the asphalt and so that asphalt does not build up on the cutters. Temporary Pavement Markings, in conformance with Section 619-3.06, shall be installed during this hardening period. If tape is used, it shall be removed before milling commences. After the CARDS have been milled and the millings have been removed, the permanent pavement markings can be installed.

**C. Equipment.** The construction equipment shall include a rotary type cutting head capable of cutting the CARD depressions to the dimensions and at the spacing indicated on the Standard Sheets. The pattern of cutting tips on the head shall be arranged to produce a relatively smooth cut with approximately 1/16 inch between peaks and valleys. Prior to beginning full production work, the contractor shall demonstrate to the Engineer the ability to achieve the desired surface without tearing or snagging the asphalt.

The cutting head shall be on its own suspension system, independent from that of the power unit, to allow the head to align itself with the slope of the pavement and/or any irregularities in the surface. The cutting tool shall be equipped with guides or a guidance system, clearly visible to the operator, to provide for consistent alignment of each CARD relative to the centerline markings.

**D. Installation and Dimensions.** The Contractor shall provide Maintenance and Protection of Traffic as indicated in the contract documents.

CARDS shall be installed within the limits indicated in the contract documents. Unless indicated otherwise in the contract documents, CARDS shall be centered on the middle of the centerline marking pattern. No milling shall be done within 4 inches of sawn and sealed transverse joints. CARDS shall not be carried through any intersection where the CARD's direction of travel is controlled by a yield sign, stop sign, or traffic light, or would encounter crosswalks. In those instances, the CARD shall stop before any stop line or crosswalk. CARDS shall not be carried through any crosswalks or across any concrete bridge deck or concrete culvert surface. Treatment for left turn lanes shall be as shown on the Standard Sheets.

At the end of each working day, the Contractor shall remove all equipment to a location where it does not present a hazard to traffic. The pavement shall be cleaned by sweeping and the work area shall be reopened to traffic. Millings shall be thoroughly removed from the work area and disposed of in an acceptable manner.

**649-4 METHOD OF MEASUREMENT.** Audible Roadway Delineators will be measured as the sum of the lengths in linear feet of the individual segments where audible roadway delineators have been satisfactorily installed. Individual gaps and exclusions under 100 feet in length will be included in segments identified for payment. Individual gaps and exclusions 100 feet or more in length will be excluded from segments identified for payment.

For milled-in audible roadway delineators, lengths will be measured along the inside edge of the shoulder from the center of the first milled-in audible roadway delineator in a segment to the center of the last milled-in audible roadway delineator in that segment. Where milled-in audible roadway delineators are provided on more than one shoulder, lengths will be measured separately for each segment and added to the sum.

For centerline audible roadway delineators, lengths will be measured along the centerline of the CARDS from the

## SECTION 649 - AUDIBLE ROADWAY DELINEATORS

center of the first centerline audible roadway delineator in a segment to the center of the last centerline audible roadway delineator in that segment.

**649-5 BASIS OF PAYMENT.** The unit price bid shall include the cost of all materials, equipment and labor necessary to satisfactorily complete the work.

***Payment will be made under:***

<b>Item No.</b>	<b>Item</b>	<b>Pay Unit</b>
649.01	Milled-In Audible Road Delineators (MIARDs)	Linear Foot
649.11	Centerline Audible Road Delineators (CARDs)	Linear Foot

## Frames, Grates and Covers

Make the following changes to the Standard Specifications of May 4, 2006/May 1, 2008:

**Delete** 655-4 METHOD OF MEASUREMENT & 655-5 BASIS OF PAYMENT in their entirety and replace them with the following:

### “655-4 METHOD OF MEASUREMENT

**655-4.01 Frames and Grates.** The quantity to be measured for payment will be the number of frames and grates satisfactorily installed.

### 655-5 BASIS OF PAYMENT

**655-5.01 Frames and Grates.** The unit price bid for each frame and grate shall include the cost of furnishing all labor, materials and equipment necessary to satisfactorily complete the work, including the cost of any field repair work for improperly fitting castings or to render the frame and grate non-rocking.

#### *Payment will be made under:*

<i>Item No.</i>	<i>Item Description</i>	<i>Pay Unit</i>
655.0701	Cast Frame F1, Mountable Curb Box CM1 & Reticuline Grate G1	Each
655.0702	Cast Frame F2, Mountable Curb Box CM2 & Reticuline Grate G2	Each
655.0703	Cast Frame F3, Mountable Curb Box CM3 & Reticuline Grate G3	Each
655.0704	Cast Frame F1, UnMountable Curb Box CU1 & Reticuline Grate G1	Each
655.0705	Cast Frame F2, UnMountable Curb Box CU2 & Reticuline Grate G2	Each
655.0706	Cast Frame F3, UnMountable Curb Box CU3 & Reticuline Grate G3	Each
655.0801	Cast Frame F1, Mountable Curb Box CM1 & Parallel Bar Grate 6 PCB	Each
655.0802	Cast Frame F2, Mountable Curb Box CM2 & Parallel Bar Grate 7 PCB	Each
655.0803	Cast Frame F3, Mountable Curb Box CM3 & Parallel Bar Grate 8 PCB	Each
655.0804	Cast Frame F1, UnMountable Curb Box CU1 & Parallel Bar Grate 6 PCB	Each
655.0805	Cast Frame F2, UnMountable Curb Box CU2 & Parallel Bar Grate 7 PCB	Each
655.0806	Cast Frame F3, UnMountable Curb Box CU3 & Parallel Bar Grate 8 PCB	Each
655.0901	Parallel Bar Frame 10 PCB & Parallel Bar Grate 10 PCB	Each
655.0902	Parallel Bar Frame 11 PCB & Parallel Bar Grate 11 PCB	Each
655.0903	Parallel Bar Frame 12 PCB & Parallel Bar Grate 12 PCB	Each
655.1003	Welded Frame & Rectangular Grate 3	Each
655.1006	Welded Frame & Rectangular Grate 6	Each
655.1011	Welded Frame & Rectangular Grate 11	Each
655.1016	Welded Frame & Rectangular Grate 16	Each
655.1022	Welded Frame & Rectangular Grate 22	Each
655.1103	Welded Frame & Reticuline Grate 3	Each
655.1106	Welded Frame & Reticuline Grate 6	Each
655.1111	Welded Frame & Reticuline Grate 11	Each
655.1116	Welded Frame & Reticuline Grate 16	Each
655.1122	Welded Frame & Reticuline Grate 22	Each
655.1201	Manhole Frame & Grate	Each
655.1202	Manhole Frame & Cover	Each
655.1301	Telescoping Manhole Frame & Grate	Each
655.1302	Telescoping Manhole Frame & Cover	Each"

**D262100**  
**CONTRACTOR CHARGES**

Make the following changes to the Standard Specification of May 4, 2006 / May 1, 2008:

**Delete** Sections 689 thru 696 and **Replace** them with the following:

**SECTIONS 689 THRU 695 (VACANT)**

**SECTION 696 CONTRACTOR CHARGES**

**696-1 DESCRIPTION.** This section will provide for the accounting of charges assessed against the Contractor in accordance with the contract documents.

**696-2 MATERIALS.** None specified.

**696-3 CONSTRUCTION DETAILS.** The Department may assess the Contractor charges for Engineering Charges and/or Liquidated Damages against monies due the Contractor in accordance with §108-03 *Failure to Complete Work On Time*, or may make other charges in accordance with the contract. These charges will be assessed using the contract pay items in this section.

**696-4 METHOD OF MEASUREMENT.** These contract pay items will not be shown in the itemized proposal. Contractor charges will be measured on a Dollars-Cents basis.

**696-5 BASIS OF PAYMENT.** Should the Contractor be assessed charges, the amounts will be accounted for using the contract pay items in this section. Assessed charges will be deducted from a contract payment processed after the determination that charges will be made, or, if the Contractor is not due monies sufficient to recover the assessed charges, the State may utilize other methods of recovery.

*Payment will be made under:*

<b>Item No.</b>	<b>Item</b>	<b>Pay Unit</b>
696.01	Engineering Charges	Dollars Cents
696.02	Liquidated Damages	Dollars Cents
696.03	Contractor Charges – Other	Dollars Cents



## PRICE ADJUSTMENTS

Make the following changes to the Standard Specifications dated May 1, 2008.  
Page 749 **Delete** Section 698 *Price Adjustments* and **Replace** it with the following:

### SECTION 698 PRICE ADJUSTMENTS

**698-1 DESCRIPTION.** This section will provide for additional compensation to the Contractor for increases, or repayment by the Contractor for decreases, in the price of asphalt, fuel, or steel/iron products.

**698-1.01 Asphalt Price Adjustment.** This item will enable the Department to make price adjustments to account for changes in asphalt prices. Price adjustments will be made for eligible work listed in the contract proposal.

**698-1.02 Fuel Price Adjustment.** This item will enable the Department to make price adjustments to account for changes in fuel prices. Price adjustments will be made for eligible work listed in the contract proposal.

**698-1.03 Steel/Iron Price Adjustment.** This item will enable the Department to make price adjustments to account for changes in steel/iron product prices for materials eligible and identified by the Contractor which will be permanently incorporated into the work.

**698-2 MATERIALS.** None specified.

**698-3 CONSTRUCTION DETAILS.** No adjustment will be provided for any new or additional work paid for by force account. Additional quantities of existing contract pay items at original bid prices will be considered eligible work. Additional work added by agreed price will be considered eligible work. Work performed by the Contractor at its own expense will not be eligible for price adjustment.

The monthly average asphalt prices, monthly average fuel prices, steel cost basis and steel index values will be posted in the Engineering Bulletin entitled *Fuel, Asphalt and Steel Price Adjustments*.

If eligible items are installed after the contract completion date, when an extension of time without the assessment of engineering charges and/or liquidated damages is approved, the monthly average posted price or monthly steel index value will be used to compute price adjustments.

If eligible items are installed after the contract completion date, when an extension of time was approved with the assessment of engineering charges and/or liquidated damages, the monthly average posted price or monthly steel index in effect on the last contract completion date without the assessment of engineering charges and/or liquidated damages, or the value for the month of installation/purchase, whichever is less, will be used to compute price adjustments.

**698-3.01 Asphalt Price Adjustment.** The asphalt price adjustment will be based solely on the price changes for asphalt as determined by the formulas below. No adjustment will be made if the monthly average posted price is within \$15.00 of the asphalt index price. No consideration will be given to the situation where an individual supplier's price exceeds the monthly average posted price.

**A. Prices.** The asphalt index price and the monthly average posted price are defined as follows:

**1. Asphalt Index Price.** The asphalt index price is a price per ton of Performance Graded Binder (PGB) used solely as a basis from which to compute asphalt price adjustments. The

## PRICE ADJUSTMENTS

asphalt index price for original contract bid price items and additional work at the original contract bid price will be the monthly average posted price for the month of the bid letting. The asphalt index price for additional work at agreed price will be the monthly average posted price for the month the agreed price was submitted to the Engineer.

**2. Monthly Average Posted Price.** The average terminal price for unmodified PG 64-22 binder, without anti-stripping agent, determined by the Department, based on prices of approved primary sources of PGB.

**B. Quantity.** The quantity of asphalt in tons considered for adjustment will be determined by multiplying the quantity of eligible work completed by the conversion factors listed in the Special Note entitled *Asphalt Price Adjustment*.

**C. Adjustment.** Asphalt price adjustment will be based on the following formulas:

**1. When price increases:** Price Adjustment = (Quantity of Asphalt) x (Monthly Average Posted Price - PGB Index Price - \$15.00)

**2. When price decreases:** Price Adjustment = (Quantity of Asphalt) x (Monthly Average Posted Price - PGB Index Price + \$15.00)

**698-3.02 Fuel Price Adjustment.** The fuel price adjustment will be based solely on the price changes for fuel as determined by the formulas below. No adjustment will be made if the monthly average posted price is within \$0.10 per gallon of the fuel index price. No consideration will be given to the situation where an individual supplier's price exceeds the monthly average posted price,

**A. Prices.** The fuel index price and the monthly average posted price are defined as follows:

**1. Fuel Index Price.** A price per gallon of fuel used solely as a basis from which to compute fuel price adjustments. The fuel index price for original contract bid price items and additional work at the original contract bid price will be the monthly average posted price for the month of the bid letting. The fuel index price for additional work at agreed price will be the monthly average posted price for the month the agreed price was submitted to the Engineer.

**2. Monthly Average Posted Price.** An average refinery or terminal price based on prices for ultra low sulfur diesel (ULSD) and gasoline.

**B. Quantity.** The quantity of fuel in gallons considered for adjustment will be determined by multiplying the quantity of eligible work completed by the fuel usage factor listed in the Special Note entitled *Fuel Price Adjustment*.

**C. Adjustment.** Fuel price adjustment will be based on the following formulas:

**1. When price increases:** Price Adjustment = (Quantity of Fuel) x (Monthly Average Posted Price - Fuel Index Price - \$0.10)

**2. When price decreases:** Price Adjustment = (Quantity of Fuel) x (Monthly Average Posted

## PRICE ADJUSTMENTS

Price - Fuel Index Price + \$0.10)

**698-3.03 Steel/Iron Price Adjustment.** Within 30 calendar days after award, the Contractor shall provide the Engineer with a list of materials to which the Contractor opts to apply the steel price adjustment, identifying the materials by groups of similar material content within a core (3 digit) contract pay item (e.g. 564 *Structural Steel* or 603.05xxxx *Corrugated Steel Pipe*). For each material listed, the Contractor shall also identify the parties whose relationship establishes the invoice date. If the two parties are known, they shall be identified by name. If the two parties are not known, they shall be identified by role (Contractor, Subcontractor, Material Supplier, Fabricator, Manufacturer, Mill, etc.). Different parties may be identified for individual or groups of contract pay items for the purposes of establishing an invoice date. If the Contractor does not provide a list of materials to which to apply the steel price adjustment, no steel price adjustment will be made.

If the percentage change for a given month does not exceed 5% plus or minus, from the benchmark steel index, no adjustments will be made for materials invoiced that month. For lump sum or each items that are assembled from numerous components, such as overhead sign structures, the percentage change will be determined for the assembled contract pay item using the month that the largest value of materials were invoiced. For unit price items such as guiderail that are assembled from numerous components, the percentage change will be determined for a given quantity of the contract pay item using the month that the largest value of component materials for that quantity of the contract pay item were invoiced.

The weight of the steel and/or iron shall exclude minor appurtenances individually weighing less than 5 lbs (i.e., nuts, bolts, washers, etc.). Precast or prestressed concrete items shall have total reinforcing steel weight listed on the approved shop drawings. The following sources shall be used, in declining order of precedence, to determine the weight of steel/iron: Department established weights of steel/iron by contract pay item per pay unit; approved shop drawings; verified shipping documents; contract documents; Standard Sheets; industry standards (i.e., AISC Manual of Steel Construction, AWWA Standards, etc.); and manufacturer's data.

**A. Indexes and Prices.** Adjustments are based on the Producer Price Index (PPI) for *Semifinished Steel Mill Products* (WPU 101702). PPI values are published by the US Department of Labor, Bureau of Labor Statistics (BLS). Recent PPI values are posted on the Office of Construction website at [www.dot.ny.gov](http://www.dot.ny.gov). A complete listing of PPI values can be found on the BLS website at <http://data.bls.gov/PDQ/outside.jsp?survey=wp>. The Cost Basis, Benchmark Steel Index, Monthly Steel Index, and the Percentage Change are defined as follows:

**1. Cost Basis (CB).** An average price of steel products in dollars per ton used solely as a cost basis from which to compute steel/iron price adjustments. The cost basis for original contract bid price items and additional work at the original contract bid price will be the cost basis listed for the month of the bid letting. The cost basis for additional work at agreed price will be the value of the cost basis for the month the agreed price was submitted to the Engineer.

**2. Benchmark Steel Index (BI).** The benchmark steel index for original contract bid price items and additional work at the original contract bid price will be the value of the preliminary PPI for the month of the bid letting. The benchmark steel index for additional work at agreed price will be the value of the preliminary PPI for the month the agreed price was submitted to the Engineer.

## PRICE ADJUSTMENTS

**3. Monthly Steel Index (MI).** Value of the preliminary PPI for the month the material is invoiced. If a preliminary PPI is not posted for a given month, the value will be the average of the preceding and following months that are posted.

**4. Percent Change.** The percent change in any given month will be determined as follows:

$$\text{Percentage Change} = \left( \frac{MI - BI}{BI} \right) \times 100$$

**B. Quantity.** The quantity of steel and/or iron for adjustment for each core (3-digit) contract pay item number (e.g., 564 – *Structural Steel*) will be measured to the nearest 0.1 Tons.

**1. Percent Change Greater Than +5%.** If the Percentage Change is greater than +5% from the benchmark steel index, Price Adjustments will be made for materials invoiced that month. The Contractor shall provide the Engineer a detailed list of the weight of eligible materials within 60 calendar days after installation, including: the contract pay item, the weight of steel/iron, the month(s) of invoice, the source used to determine the weight, and if requested by the Engineer, copies of invoices to verify the month of invoice.

**2. Percent Change -5% to +5%.** If the Percentage Change is between -5% and +5%, inclusive, from the benchmark steel index, no adjustments will be made for materials invoiced that month.

**3. Percent Change Lower Than -5%.** If the Percentage Change is lower than -5% from the benchmark steel index, a Price Adjustment will be charged to the Contractor for materials invoiced that month. The Contractor shall provide the Engineer a detailed list of the weight of eligible materials within 60 calendar days after installation, including: the contract pay item, the weight of steel/iron, the month(s) of invoice, the source used to determine the weight, and copies of invoices to verify the month of invoice.

**C. Adjustment.** Steel/Iron price adjustment will be made for the materials which the Contractor opted to apply the steel price adjustment, based on the following formulas:

1. When price increases:

$$\text{Price Adjustment} = \left[ \left( \frac{MI - BI}{BI} \right) - 0.05 \right] (CB) Qty$$

2. When price decreases:

$$\text{Price Adjustment} = - \left[ \left( \frac{MI - BI}{BI} \right) + 0.05 \right] (CB) Qty$$

**698-4 METHOD OF MEASUREMENT. 698-4.01 Asphalt Price Adjustment.** Asphalt price adjustments will be measured on a Dollar Cents basis.

**698-4.02 Fuel Price Adjustment.** Fuel price adjustments will be measured on a Dollar Cents basis.

**PRICE ADJUSTMENTS**

**698-4.03 Steel/Iron Price Adjustment.** Steel/Iron price adjustments will be measured on a Dollar Cents basis.

**698-5 BASIS OF PAYMENT.** The unit price shown in the itemized proposal will be considered the unit price bid, although actual payment will be calculated based on changes in posted material prices. Should the amount shown be altered, the altered figures will be disregarded and the original price will be used to determine the total contract bid amount.

If price adjustments are based on estimated material quantities, and a revision to the estimated material quantity is made in a subsequent or final estimate, an appropriate addition or deduction will be made to the price adjustment previously calculated. The addition or deduction will be based on the adjustment factors initially used to calculate the price adjustment. If the installation dates of the revised material quantity cannot be determined, the addition or deduction will be based on the adjustment factors in effect during the last month in which any portion of the material quantity was installed.

**698-5.01 Asphalt Price Adjustment.** The asphalt price adjustment will be based on the monthly average posted price in effect at the time the work is completed, calculated using the price adjustment formula described above.

**698-5.02 Fuel Price Adjustment.** The fuel price adjustment will be based on the monthly average posted price in effect at the time the work is completed, calculated using the price adjustment formula described above.

**698-5.03 Steel/Iron Price Adjustment.** The steel/iron price adjustment will be based on the monthly steel index in effect at the time of invoice between the two parties previously identified by the Contractor, calculated using the price adjustment formula described above.

***Payment will be made under:***

<b>Item No.</b>	<b>Item</b>	<b>Pay Unit</b>
698.04	Asphalt Price Adjustment	Dollars Cents
698.05	Fuel Price Adjustment	Dollars Cents
698.06	Steel/Iron Price Adjustment	Dollars Cents

## SECTION 701 – HYDRAULIC CEMENTS

Make the following changes to the Standard Specifications of May 1, 2008:

**Page 758** Under ' **701-04 CONCRETE REPAIR MATERIAL**, *delete* the section in its entirety, and *replace* it with the following:

**701-04 CONCRETE REPAIR MATERIAL**

**SCOPE.** The material covered in this specification is generally used for shallow repairs of portland cement concrete, including repair of precast concrete products, such as pipe, cribbing, manholes, etc...

**GENERAL.** The use of this material is limited to repair areas smaller than 5 ft<sup>2</sup> and not deeper than 2 in. This material is meant to be applied and finished with a trowel in a horizontal position. The Department will test the material in accordance with Test Method NY 701-13P,C following the manufacturer's proportioning and mixing instructions printed on the package. Material meeting the requirements of this specification will be placed on the Approved List. For field use, follow the manufacturers mixing and curing recommendations.

**MATERIAL REQUIREMENTS.** The material shall be a prepackaged dry component: to which water or emulsified compound is added, used for concrete repair, containing no metallic expansion aides, to which no aggregate may be added, meeting the requirements of Table 701-04. When being used for aesthetic purposes the material's color shall be within the Munsell Neutral Scale range stated in Table 701-04.

<b>TABLE 701-04 CONCRETE REPAIR MATERIAL</b>		
<b>TEST REQUIREMENT</b>	<b>Min.</b>	<b>Max.</b>
Initial Set (minutes)	10	60
Expansion (%)	-	0.4
Contraction (%)	-	0.0
1 Day Compressive Strength (psi)	3000	-
7 Day Compressive Strength (psi)	5000	-
28 Day Compressive Strength (psi)	6000	-
1 Day Bond Strength (psi)	200	-
Freeze/Thaw Loss % (25 cycles)	-	1.0
Total Chloride Content (% by weight)	-	0.05
Total Sulfate Content (% by weight)	-	5.0
Color, Munsell Neutral Scale	4.0	8.5

**SECTION 701 – HYDRAULIC CEMENTS**

**BASIS OF APPROVAL.** Application for material approval shall be submitted to the Materials Bureau by the manufacturer. The application shall be accompanied by a labeled 50 lb production sample of the product; however the Materials Bureau will approve other packaging quantities on a case-by-case basis. The Department will test the material according to Test Method NY 701-13P,C following the manufacturer's proportioning and mixing instructions printed on the package. Upon approval, the product brand name, manufacturing location and shelf life will be placed on the Approved List. The Department must receive a letter from the manufacturer annually certifying that no changes have been made in the formulation, manufacturing process, or manufacturing location. In the event that a letter is not received, the product may be removed from the Approved List. Furthermore, the material may be removed from the Approved List at any time if the Department is not notified in writing of any material changes as stated above. The Department reserves the right to sample and test the material at any time.

**BASIS OF ACCEPTANCE.** Products will be accepted on the basis of the brand name and manufacturing location appearing on the Approved List. Such products will then be accepted on the basis of the brand name and manufacturing location printed on the sealed, non reusable container along with the month and year (i.e. 05/2011) of when the material was manufactured. The manufacturer is required to print the shelf life on the container if it is less than 12 months. The expiration date of acceptance for this material shall be one calendar year from the date of manufacture or as stated in the Approved List, whichever is less.

**Page 758** Under ' **701-05 CONCRETE GROUTING MATERIAL**, *delete* the section in its entirety, and *replace* it with the following:

**701-05 CONCRETE GROUTING AND ANCHORING MATERIAL**

**SCOPE.** This specification covers the requirements for grouting material used to grout anchor bolts, dowels and other items in portland cement concrete. This material can also be used for forming mortar pads under bridge rail supports.

**GENERAL.** This material should not be used in layers thicker than 2 in. The Department will test the material according to Test Method NY 701-11P,C following the manufacturer's proportioning and mixing instructions printed on the package. Material meeting the requirements of this specification will be placed on the Approved List. For field use, follow the manufacturers mixing and curing recommendations.

**MATERIAL REQUIREMENTS.** The material shall be a prepackaged, dry component: to which water or emulsified compound is added, used for concrete repair, containing no metallic expansion aides, to which no aggregate may be added, meeting the requirements of Table 701-05.

<b>TABLE 701-05 CONCRETE GROUTING AND ANCHORING MATERIAL</b>		
<b>TEST REQUIREMENT</b>	<b>Min.</b>	<b>Max.</b>
Initial Set (minutes)	30	-
Expansion (%)	-	0.4

## SECTION 701 – HYDRAULIC CEMENTS

Contraction (%)	-	0.0
1 Day Compressive Strength (psi)	3000	-
7 Day Compressive Strength (psi)	6000	-
Pullout Strength (lbs)	10000	-
Freeze-Thaw Loss % (25 cycles)	-	1.0
Total Chloride Content (% by weight)	-	0.05
Total Sulfate Content (% by weight)	-	5.0

**BASIS OF APPROVAL.** Application for material approval shall be submitted to the Materials Bureau by the manufacturer. The application shall be accompanied by a labeled 50 lb production sample of the product; however the Materials Bureau will approve other packaging quantities on a case-by-case basis. The Department will test the material according to Test Method NY 701-11P,C following the manufacturer's proportioning and mixing instructions printed on the package. Upon approval, the product brand name, manufacturing location and shelf life will be placed on the Approved List. The Department must receive a letter from the manufacturer annually certifying that no changes have been made in the formulation, manufacturing process, or manufacturing location. In the event that a letter is not received, the product may be removed from the Approved List. Furthermore, the material may be removed from the Approved List at any time if the Department is not notified in writing of any material changes as stated above. The Department reserves the right to sample and test the material at any time.

**BASIS OF ACCEPTANCE.** Products will be accepted on the basis of the brand name and manufacturing location appearing on the Approved List. Such products will then be accepted on the basis of the brand name and manufacturing location printed on the sealed, non reusable container along with the month and year (i.e. 05/2011) of when the material was manufactured. The manufacturer is required to print the shelf life on the container if it is less than 12 months. The expiration date of acceptance for this material shall be one calendar year from the date of manufacture or as stated in the Approved List, whichever is less.

**Page 759** Under ' **701-06 CEMENT BASED GROUT MATERIALS FOR SHEAR KEYS**, *delete* the section in its entirety, and *replace* it with the following:

**701-06 SHEAR KEY GROUT**

**SCOPE.** This specification covers the requirements for grout to be placed in shear keys between precast concrete structural units.

**GENERAL.** The material must be flowable to fill the shear key with no voids. The Department will test the material in accordance with Test Method NY 701-12P,C following the manufacturer's proportioning and mixing instructions printed on the package. Material meeting the requirements of this specification will be placed on the Approved List. The Approved List titled: Shear Key Grout will state the precise water-grout ratio by weight. This ratio shall not be altered. For field use, follow the manufacturers mixing and curing recommendations.



## SECTION 701 – HYDRAULIC CEMENTS

**MATERIAL REQUIREMENTS.** The material shall be a prepackaged dry component: to which water or emulsified compound is added, used for concrete repair, containing no metallic expansion aides, to which no aggregate may be added. The material must meet the shear key pourability test as per Test Method NY 701-12P,C and the requirements of Table 701-06.

<b>TABLE 701-06 SHEAR KEY GROUT</b>		
<b>TEST REQUIREMENT</b>	<b>Min.</b>	<b>Max.</b>
Initial Set (minutes)	120	-
Expansion (%)	0.02	1.0
Contraction (%)	-	0.0
7 Day Compressive Strength (psi)	6000	-
Freeze-Thaw Loss % (25 cycles)	-	1.0
Total Chloride Content (% by weight)	-	0.05
Total Sulfate Content (% by weight)	-	5.0

**BASIS OF APPROVAL.** Application for material approval shall be submitted to the Materials Bureau by the manufacturer. The application shall be accompanied by a labeled 50 lb production sample of the product; however the Materials Bureau will approve other packaging quantities on a case-by-case basis. The Department will test the material according to Test Method NY 701-12P,C following the manufacturer's proportioning and mixing instructions printed on the package. Upon approval, the product brand name, manufacturing location and shelf life will be placed on the Approved List. The Department must receive a letter from the manufacturer annually certifying that no changes have been made in the formulation, manufacturing process, or manufacturing location. In the event that a letter is not received, the product may be removed from the Approved List. Furthermore, the material may be removed from the Approved List at any time if the Department is not notified in writing of any material changes as stated above. The Department reserves the right to sample and test the material at any time.

**BASIS OF ACCEPTANCE.** Products will be accepted on the basis of the brand name and manufacturing location appearing on the Approved List. Such products will then be accepted on the basis of the brand name and manufacturing location printed on the sealed, non reusable container along with the month and year (i.e. 05/2011) of when the material was manufactured. The manufacturer is required to print the shelf life on the container if it is less than 12 months. The expiration date of acceptance for this material shall be one calendar year from the date of manufacture or as stated in the Approved List, whichever is less.

**Page 761** Under ' **701-08 VERTICAL AND OVERHEAD PATCHING MATERIAL**, *delete* the section in its entirety, and *replace* it with the following:

## SECTION 701 – HYDRAULIC CEMENTS

## 701-08 VERTICAL AND OVERHEAD REPAIR MATERIAL

**SCOPE.** This specification covers the requirements for Vertical and Overhead Repair Material for placement in structural concrete repairs.

**GENERAL.** The use of this material is limited to repair areas smaller than 4 ft<sup>2</sup> and not deeper than 2 in, and is meant to be applied and finished with a trowel. The Materials Bureau will consider other application techniques on a case by case basis. The Department will test the material in accordance with Test Method NY 701-17P,C following the manufacturer's proportioning and mixing instructions printed on the package. Material meeting the requirements of this specification will be placed on the Approved List. For field use, follow the manufacturers mixing and curing recommendations.

**MATERIAL REQUIREMENTS.** The material shall be a prepackaged dry component: to which water or emulsified compound is added, used for concrete repair, containing no metallic expansion aides, to which no aggregate may be added. The material shall be able to be placed in layers of at least 1 inch on overhead applications without the use of formwork or anchoring devices. When being used for aesthetic purposes the material's color shall be within the Munsell Neutral Scale range stated in Table 701-08.

<b>TABLE 701-08 VERTICAL AND OVERHEAD REPAIR MATERIAL</b>		
<b>TEST REQUIREMENT</b>	<b>Min.</b>	<b>Max.</b>
Initial Set (minutes)	15	-
Expansion (%)	-	0.4
Contraction (%)	-	0.0
7 Day Compressive Strength (psi)	4000	-
28 Day Compressive Strength (psi)	5000	
1 Day Bond Strength (psi)	200	-
Freeze-Thaw Loss % (25 cycles)	-	1.0
Total Chloride Content (% by weight)	-	0.05
Total Sulfate Content (% by weight)	-	5.0
Color, Munsell Neutral Scale	4.0	8.5

**BASIS OF APPROVAL.** Application for material approval shall be submitted to the Materials Bureau by the manufacturer. The application shall be accompanied by a labeled 50 lb production sample of the product; however the Materials Bureau will approve other packaging quantities on a case-by-case basis. The Department will test the material according to Test Method NY 701-17P,C following the manufacturer's proportioning and mixing instructions printed on the package. Upon approval, the product brand name, manufacturing location and shelf life will be placed on the Approved List. The Department must receive a letter from the manufacturer annually certifying that no changes have been made in the

**SECTION 701 – HYDRAULIC CEMENTS**

formulation, manufacturing process, or manufacturing location. In the event that a letter is not received, the product may be removed from the Approved List. Furthermore, the material may be removed from the Approved List at any time if the Department is not notified in writing of any material changes as stated above. The Department reserves the right to sample and test the material at any time.

**BASIS OF ACCEPTANCE.** Products will be accepted on the basis of the brand name and manufacturing location appearing on the Approved List. Such products will then be accepted on the basis of the brand name and manufacturing location printed on the sealed, non reusable container along with the month and year (i.e. 05/2011) of when the material was manufactured. The manufacturer is required to print the shelf life on the container if it is less than 12 months. The expiration date of acceptance for this material shall be one calendar year from the date of manufacture or as stated in the Approved List, whichever is less.

**Page 762** Under ' **701-09 RAPID HARDENING CONCRETE REPAIR MATERIAL (Normal Weather)**, *delete* the section in its entirety, and *replace* it with the following:

**701-09 CONCRETE REPAIR MATERIAL - RAPID HARDENING**

**SCOPE.** This specification covers the requirements for material to repair portland cement concrete where rapid strength gain is required.

**GENERAL.** Its use is limited to areas no larger than 10 ft<sup>2</sup> or 5 ft<sup>3</sup> in volume for a single patch. This material is intended for partial or full depth repairs. This material may be extended with dried Department approved CA1 coarse aggregate. This product must provide the ability to accept traffic loads within 1 hour of placement. The Department will test the material neat except where noted in Table 701-09 to test neat and extended according to Test Method NY 701-21P,C following the manufacturer's proportioning and mixing instructions printed on the package. Material meeting the requirements of this specification when tested (Neat and Extended), will be placed on the Approved List.

**MATERIAL REQUIREMENTS.** This material shall be a prepackaged, multi-component powdered material, containing no metallic expansion aides, and must remain workable when a minimum of 60% extended by weight with Department approved CA1 coarse aggregate and meets the requirements of Table 701-09. When being used for aesthetic purposes the material's color shall be within the Munsell Neutral Scale range stated in Table 701-09.

<b>TABLE 701-09 CONCRETE REPAIR MATERIAL - RAPID HARDENING</b>		
<b>TEST REQUIREMENT</b>	<b>Min.</b>	<b>Max.</b>
Initial Set (minutes)	5	-
Expansion (%)	-	0.4
Contraction (%)	-	0.0
1 Hour Compressive Strength (psi)	2000	-

## SECTION 701 – HYDRAULIC CEMENTS

3 Hour Compressive Strength (psi) **	3000	-
7 Day Compressive Strength (psi)	6000	-
1 Day Bond Strength (psi)	200	-
Freeze-Thaw Loss % (25 cycles)**	-	1.0
Total Chloride Content (% by weight)	-	0.05
Total Sulfate Content (% by weight)	-	5.0
Color, Munsell Neutral Scale	4.0	8.5

\*\* Neat and Extended

**BASIS OF APPROVAL.** Application for material approval shall be submitted to the Materials Bureau by the manufacturer. The application shall be accompanied by a labeled 50 lb production sample of the product; however the Materials Bureau will approve other packaging quantities on a case-by-case basis. The Department will test the material according to Test Method NY 701-21P,C following the manufacturer's proportioning and mixing instructions printed on the package. Upon approval, the product brand name, manufacturing location and shelf life will be placed on the Approved List. The Department must receive a letter from the manufacturer annually certifying that no changes have been made in the formulation, manufacturing process, or manufacturing location. In the event that a letter is not received, the product may be removed from the Approved List. Furthermore, the material may be removed from the Approved List at any time if the Department is not notified in writing of any material changes as stated above. The Department reserves the right to sample and test the material at any time.

**BASIS OF ACCEPTANCE.** Products will be accepted on the basis of the brand name and manufacturing location appearing on the Approved List. Such products will then be accepted on the basis of the brand name and manufacturing location printed on the sealed, non reusable container along with the month and year (i.e. 05/2011) of when the material was manufactured. The manufacturer is required to print the shelf life on the container if it is less than 12 months. The expiration date of acceptance for this material shall be one calendar year from the date of manufacture or as stated in the Approved List, whichever is less.

Make the following changes to the Standard Specifications of May 1, 2008:

Page 781, **remove** 704-02 in its entirety and **replace** it with the following:

**“704-02 CONCRETE BRICK**

**SCOPE.** This specification covers the material and quality requirements for concrete brick produced in accordance with the current Materials Procedure for Concrete Masonry QC/QA titled “Procedures for Achieving and Maintaining Concrete Masonry Units Approved List Status”. Item 704-02 can be used in brick masonry construction, altering drainage structures, leaching-basins and manholes (section 604).

**MATERIAL REQUIREMENTS.** Concrete brick shall conform to the requirements of ASTM C936, except as noted herein. Certain aggregates appear in the Approved List of Sources of Fine and Coarse Aggregates that have use limitations with high alkali Portland Cement. Materials used in the manufacture of concrete brick shall meet the requirements of the following subsections:

Portland Cement	701-01
Coarse Aggregate	703-02
Mortar Sand	703-03
Grout Sand	703-04
Concrete Sand	703-07
Fly Ash	711-10
Ground, Granulated Blast-Furnace Slag	711-12
Water	712-01

Fly ash or ground, granulated blast-furnace slag may be substituted up to a maximum of 20% by weight of the total amount of cement plus pozzolan in the mix. Pigments used for integral coloring shall meet the requirements of ASTM C979. Other materials may be used in the manufacture as approved by the Director, Materials Bureau. The nominal dimensions of the brick shall be 8 inches long, 4 inches wide, and 2⅔ inches in height.

**Physical Properties.** Concrete brick shall meet the compressive strength and absorption requirements in ASTM C936. In addition, the maximum acceptable average freeze/thaw loss of five paver samples, subjected to 25 freeze/thaw cycles in a 10% NaCl solution, is 1.0%, with no individual sample exceeding 1.5%.

**SAMPLING AND TESTING.** When samples are requested by the Department, they will be randomly selected from production-run material. A total of 15 concrete bricks of the same size and style will be required. Five samples will be tested for compressive strength and five for absorption, in accordance with ASTM C140. Five samples will be tested for freeze/thaw durability in accordance with NYSDOT test methods.

**BASIS OF ACCEPTANCE.** Concrete brick will be accepted on the job site based on the following:

- The manufacturer's name must appear on the Department's Approved List for the item being supplied.
- A manufacturer's certification.
- An acceptable product evaluation made by the Engineer.”

**D262100**  
**SECTION 704 – MASONRY UNITS**

Page 788, **remove** 704-04 in its entirety and **replace** with the following:

**"704-04 CONCRETE BLOCK (SLOPE PAVING)**

**SCOPE.** This specification covers the material details and quality requirements for concrete block for use in concrete block slope paving and produced in accordance with the current Materials Procedure for Concrete Masonry QC/QA titled "Procedures for Achieving and Maintaining Concrete Masonry Units Approved List Status".

**MATERIAL REQUIREMENTS.** Certain aggregates appear in the Approved List of Sources of Fine and Coarse Aggregates that have use limitations with high alkali Portland Cement. Materials used in the manufacture of concrete block shall meet the requirements of the following subsections:

Portland Cement	701-01
Coarse Aggregate	703-02
Mortar Sand	703-03
Grout Sand	703-04
Concrete Sand	703-07
Fly Ash	711-10
Ground, Granulated Blast-Furnace Slag	711-12
Water	712-01

Fly ash or ground granulated blast furnace slag may be substituted for up to a maximum of 20% by weight of the total amount of cement plus pozzolan in the mix. Pigments used for integral coloring shall meet the requirements of ASTM C979. Other materials may be used in the manufacture as approved by the Director, Materials Bureau.

**Physical Properties.** The minimum acceptable average compressive strength of five-block samples is 6000 psi, with no individual block less than 5500 psi. The maximum acceptable average freeze/thaw loss of five-block samples, subjected to 42 freeze/thaw cycles in a 3% NaCl solution, shall not exceed 1.0%, with no individual sample exceeding 1.5%.

Block dimensions shall be as required in the contract documents. Dimensions shall not vary by more than ¼ inch from those specified. Blocks shall be sound and free from cracks or other defects that would interfere with their proper placement or performance.

**SAMPLING AND TESTING.** When samples are requested by the Department, they will be randomly selected from production-run material. A minimum of five samples, prepared by the manufacturer in accordance with ASTM C1262, will be required for freeze/thaw testing.

Samples will be tested for compressive strength in accordance with ASTM C140. Samples will be tested for freeze/thaw durability in accordance with ASTM C1262.

**BASIS OF ACCEPTANCE.** Concrete block will be accepted on the job site based on the following:

- The manufacturer's name must appear on the Department's Approved List for the item being supplied.
- A manufacturer's certification.
- An acceptable product evaluation made by the Engineer."

Page 790, **remove** 704-07 in its entirety and **replace** with the following:

**“704-07 SEGMENTAL RETAINING WALL BLOCKS**

**SCOPE.** This specification covers the material details and quality requirements for segmental retaining wall blocks produced in accordance with the current Materials Procedure for Concrete Masonry QC/QA titled “Procedures for Achieving and Maintaining Concrete Masonry Units Approved List Status”.

**MATERIAL REQUIREMENTS.** Provide segmental retaining wall block meeting the style and color requirements in the contract documents. Certain aggregates appear in the Approved List of Sources of Fine and Coarse Aggregates that have use limitations with high alkali Portland cement. Use materials, meeting the following requirements, in the manufacture of segmental retaining wall blocks:

Portland Cement	701-01
Coarse Aggregate	703-02
Mortar Sand	703-03
Grout Sand	703-04
Concrete Sand	703-07
Fly Ash	711-10
Ground, Granulated Blast-Furnace Slag	711-12
Water	712-01

Fly ash or ground, granulated blast-furnace slag may be substituted for up to a maximum of 20% by weight of the total amount of cement plus pozzolan in the mix. Use integral coloring pigments, when required, meeting the requirements of ASTM C979. Other materials may be used in the manufacture as approved by the Director, Materials Bureau.

**Physical Properties.** The minimum acceptable average compressive strength of five-block samples is 6000 psi, with no individual block sample less than 5500 psi. The maximum acceptable average freeze/thaw loss of five-block samples, subjected to 42 freeze/thaw cycles in a 3% NaCl solution, is 1.0%, with no individual sample exceeding 1.5%.

The formed dimensions of concrete retaining wall block units will not differ more than ¼ inch from the nominal dimensions shown on the approved Materials Detail Drawing. Provide sound blocks, free from cracks or other defects that would interfere with the proper placing, performance, or appearance of the blocks.

**Materials Details.** At the time of application to the Approved List, submit Materials Details Drawings to the Director, Materials Bureau for approval. Prepare and submit drawings in accordance with Departmental procedural directives. Submit a unique drawing(s) for each block style under consideration.

**SAMPLING AND TESTING.** When samples are requested by the Department, they will be randomly selected from production-run material. A minimum of 5 samples, prepared by the manufacturer in accordance with ASTM C140, will be required for compression testing. A minimum of five samples, prepared by the manufacturer in accordance with ASTM C1262, will be required for freeze/thaw testing.

Samples will be tested for compressive strength in accordance with ASTM C140. Samples will be tested for freeze/thaw durability in accordance with ASTM C1262.

**BASIS OF ACCEPTANCE.** Segmental retaining wall blocks will be accepted on the job site based on

**D262100**  
**SECTION 704 – MASONRY UNITS**

the following:

- The manufacturer's name and block style must appear on the Department's Approved List for the item being supplied.
- A manufacturer's certification.
- Conformance to the approved material detail drawing(s).
- An acceptable product evaluation made by the Engineer."

Page 792, **remove** 704-10 in its entirety and **replace** with the following:

**“704-10 SPLIT-FACED CONCRETE BRICK**

**SCOPE.** This specification covers the material details and quality requirements for split faced concrete brick for use in facing structural walls and produced in accordance with the current Materials Procedure for Concrete Masonry QC/QA titled “Procedures for Achieving and Maintaining Concrete Masonry Units Approved List Status”.

**MATERIAL REQUIREMENTS.** Split-faced concrete brick shall conform to the requirements of ASTM C90, except as noted herein. The shape, size, and color of split-faced concrete brick shall be as shown in the contract documents. The splitting operation shall leave relatively sharp, straight and parallel edges. Certain aggregates appear in the Approved List of Sources of Fine and Coarse Aggregates that have use limitations with high alkali Portland Cement. Materials used in the manufacture of split-faced concrete brick shall meet the requirements of the following subsections:

Portland Cement	701-01
Coarse Aggregate	703-02
Mortar Sand	703-03
Grout Sand	703-04
Concrete Sand	703-07
Fly Ash	711-10
Ground, Granulated Blast-Furnace Slag	711-12
Water	712-01

Fly ash or ground, granulated blast-furnace slag may be substituted for up to a maximum of 20% by weight of the total amount of cement plus pozzolan in the mix. Pigments used for integral coloring shall meet the requirements of ASTM C979. Other materials may be used in the manufacture as approved by the Director, Materials Bureau.

**SAMPLING AND TESTING.** When samples are requested by the Department, they will be randomly selected from production-run material. A minimum of 10 full-size, split-faced bricks of the same size and style will be required. Five samples will be tested for compressive strength and five for absorption, in accordance with ASTM C140.

The manufacturer shall be responsible for having brick tested for linear drying shrinkage in accordance with ASTM C90. A copy of the test report shall be included with the samples submitted to the Department for compression and absorption testing.

**BASIS OF ACCEPTANCE.** Split-faced concrete brick will be accepted on the job site based on the following:

- The manufacturer's name must appear on the Department's Approved List for the item being



supplied.

- A manufacturer’s certification.
- An acceptable product evaluation made by the Engineer.”

Page 793, **remove** 704-12 in its **entirety** and replace with the following:

**“704-12 CONCRETE BLOCK**

**SCOPE.** This specification covers the material and quality requirements for concrete block for use in structural walls and produced in accordance with the current Materials Procedure for Concrete Masonry QC/QA titled “Procedures for Achieving and Maintaining Concrete Masonry Units Approved List Status”.

**MATERIAL REQUIREMENTS.** Concrete block shall conform to the requirements of ASTM C90 except as noted herein. The shape, size, and color of concrete block shall be as shown in the contract documents. Certain aggregates appear in the Approved List of Sources of Fine and Coarse Aggregates that have use limitations with high alkali Portland Cement. Materials used in the manufacture of concrete block shall meet the requirements of the following subsections:

Portland Cement	701-01
Coarse Aggregate	703-02
Mortar Sand	703-03
Grout Sand	703-04
Concrete Sand	703-07
Fly Ash	711-10
Ground, Granulated Blast-Furnace Slag	711-12
Water	712-01

Fly ash or ground, granulated blast-furnace slag may be substituted for up to a maximum of 20% by weight of the total amount of cement plus pozzolan in the mix. Pigments used for integral coloring shall meet the requirements of ASTM C979. Other materials may be used in the manufacture as approved by the Director, Materials Bureau.

**SAMPLING AND TESTING.** When samples are requested by the Department, they will be randomly selected from production-run material. A minimum of 10 full-size concrete blocks of the same size and style will be required. Five samples will be tested for compressive strength and five for absorption, in accordance with ASTM C140.

The manufacturer shall be responsible for having block tested for linear drying shrinkage in accordance with ASTM C90. A copy of the test report shall be included with the samples submitted to the Department for compression and absorption testing.

**BASIS OF ACCEPTANCE.** Concrete block will be accepted on the job site based on the following:

- The manufacturer’s name must appear on the Department’s Approved List for the item being supplied.
- A manufacturer’s certification.
- An acceptable product evaluation made by the Engineer.”

Page 794, **remove** 704-13 in its **entirety** and **replace** with the following:

**D262100**  
**SECTION 704 – MASONRY UNITS**

**“704-13 PRECAST CONCRETE DRIVEWAY AND SIDEWALK PAVERS**

**SCOPE.** This specification covers the material details and quality requirements for precast concrete pavers used for driveway and sidewalk paving and produced in accordance with the current Materials Procedure for Concrete Masonry QC/QA titled “Procedures for Achieving and Maintaining Concrete Masonry Units Approved List Status”.

**MATERIAL REQUIREMENTS.** Precast concrete pavers shall meet the requirements of ASTM C936 except as noted herein. The shape, size, and color of precast concrete pavers shall be as shown in the Contract documents. Certain aggregates appear in the Approved List of Sources of Fine and Coarse Aggregates that have use limitations with high alkali Portland Cement. Materials used in the manufacture of precast concrete pavers shall meet the requirements of the following subsections:

Portland Cement	701-01
Coarse Aggregate	703-02
Mortar Sand	703-03
Grout Sand	703-04
Concrete Sand	703-07
Fly Ash	711-10
Ground, Granulated Blast-Furnace Slag	711-12
Water	712-01

Fly ash or ground, granulated blast-furnace slag may be substituted for up to a maximum of 20% by weight of the total amount of cement plus pozzolan in the mix. Pigments used for integral coloring shall meet the requirements of ASTM C979. Other materials may be used in the manufacture as approved by the Director, Materials Bureau.

**Physical Properties.** Precast concrete pavers shall meet the compressive strength and absorption requirements of ASTM C936. In addition, the maximum acceptable average freeze/thaw loss of five paver samples, subjected to 25 freeze/thaw cycles in a 10% NaCl solution, is 1.0%, with no individual sample exceeding 1.5%.

**SAMPLING AND TESTING.** When samples are requested by the Department, they will be randomly selected from production-run material. A total of 15 precast concrete pavers of the same size and style will be required. Five samples will be tested for compressive strength and five for absorption, in accordance with ASTM C140. Five samples will be tested for freeze/thaw durability in accordance with NYSDOT test methods.

**BASIS OF ACCEPTANCE.** Precast concrete driveway and sidewalk pavers will be accepted on the job site based on the following:

- The manufacturer's name must appear on the Department's Approved List for the item being supplied.
- A manufacturer's certification.
- An acceptable product evaluation made by the Engineer.”

Page 798, **remove** 704-23 in its entirety and **replace** with the following:

**“704-23 PRECAST CONCRETE STREET PAVERS**

**SCOPE.** This specification covers the material and quality requirements for precast concrete pavers used for street paving and produced in accordance with the current Materials Procedure for Concrete Masonry QC/QA titled “Procedures for Achieving and Maintaining Concrete Masonry Units Approved List Status”.

**MATERIAL REQUIREMENTS.** Precast concrete pavers shall meet the requirements of ASTM C936 except as noted herein. The shape, size, and color of precast concrete pavers shall be as shown in the contract documents. Minimum thickness for precast concrete street pavers shall be 3 1/8 inches. Certain aggregates appear in the Approved List of Sources of Fine and Coarse Aggregates that have use limitations with high alkali Portland cement. Materials used in the manufacturing of precast concrete pavers shall meet the requirements of the following subsections:

Portland Cement	701-01
Coarse Aggregate*	703-02
Mortar Sand*	703-03
Grout Sand*	703-04
Concrete Sand*	703-07
Fly Ash	711-10
Ground, Granulated Blast-Furnace Slag	711-12
Water	712-01

\* **Aggregates.** For precast concrete pavers or equivalent products placed in concrete highway wearing surfaces, use aggregate from a source or sources on the “Approved List of Sources of Fine and Coarse Aggregate.” All aggregate must be approved for use in concrete. Fine aggregate, natural or manufactured sand, must meet the requirements of §703-01, Fine Aggregate. Crushed stone, crushed gravel, or crushed slag from a coarse aggregate source must meet the requirements of §703-02, Coarse Aggregate.

Aggregate friction requirements: Sample and test aggregate for friction characteristics according to the procedures of Materials Method 28 “Friction Aggregate Control and Test Procedures”, PCC Sand. The Engineer will identify pavement areas, if any, represented by failing samples according to the procedures of Materials Method 28 “Friction Aggregate Control and Test Procedures.”

Aggregate must contain at least 25.0% acid-insoluble residue in the plus No. 30 size fraction and in the minus No. 30, plus No. 200 size fraction. If more than one source of aggregate is used, aggregate from each source must meet the acid-insoluble residue requirements.

Fly ash or ground, granulated blast-furnace slag may be substituted up to a maximum of 20% by weight of the total amount of cement plus pozzolan in the mix. Pigments used for integral coloring shall meet the requirements of ASTM C979. Other materials may be used in the manufacture as approved by the Director, Materials Bureau.

**Physical Properties.** Precast concrete pavers shall meet the compressive strength and absorption requirements of ASTM C936. In addition, the maximum acceptable average freeze/thaw loss of five paver samples, subjected to 25 freeze/thaw cycles in a 10% NaCl solution, is 1.0%, with no individual

**D262100**  
**SECTION 704 – MASONRY UNITS**

sample exceeding 1.5%.

**SAMPLING AND TESTING.** When samples are requested by the Department, they will be randomly selected from production-run material. A total of 15 precast concrete pavers of the same size and style will be required. Five samples will be tested for compressive strength and five for absorption, in accordance with ASTM C140. Five samples will be tested for freeze/thaw durability in accordance with NYSDOT test methods.

**BASIS OF ACCEPTANCE.** Precast Concrete Street pavers will be accepted on the job site based on the following:

- The manufacturer's name must appear on the Department's Approved List for the item being supplied.
- A manufacturer's certification.
- An acceptable product evaluation made by the Engineer."

**704-24 - PRECAST CONCRETE PANELS**

Make the following changes to the Standard Specifications dated May 1, 2008:

**Page 799 Add** the following:

**704-24 - PRECAST CONCRETE PANELS**

**SCOPE.** This specification covers the material and fabrication requirements for precast concrete panels.

**MATERIAL REQUIREMENTS.** The Material Requirements contained in §704-03 shall apply.

**DRAWINGS.** The Drawing requirements contained in §704-03 shall apply.

**FABRICATION.** The Fabrication requirements contained in §704-03 shall apply.

**SAMPLING AND TESTING.** The Sampling And Testing requirements contained in §704-03 shall apply.

**MARKING.** The Marking requirements contained in §704-03 shall apply.

**FINAL PRODUCTION INSPECTION.** The Final Production Inspection requirements contained in §704-03 shall apply.

**SHIPPING.** The Shipping requirements contained in §704-03 shall apply.

**BASIS OF ACCEPTANCE.** The Basis Of Acceptance requirements contained in §704-03 shall apply.

**709-15 GROUTED REINFORCING BAR SPLICE SLEEVES**

Make the following changes to Standard Specifications Construction and Materials of May 1, 2008.

**Page 352, §556-2 MATERIALS:** add the following to the list of materials:

Grouted Reinforcing Bar Splice Sleeves                      709-15

**Page 379, §563-2 MATERIALS:** add the following before **§563-3 CONSTRUCTION DETAILS:**

563-2.07 Grouted Reinforcing Bar Splice Sleeves shall meet the requirements of §709-15 Grouted Reinforcing Bar Splice Sleeves.

**Page 852,** before **SECTION 710- FENCE AND GUIDE RAIL,** add the following:

**709-15 GROUTED REINFORCING BAR SPLICE SLEEVES**

**SCOPE.** This specification covers the material requirements for Grouted Splice Sleeves. The splice sleeve and the grout constitute a system, and both parts of the system will appear together on the Approved List.

**MATERIAL REQUIREMENTS**

Grouted splice sleeves may be made of plain steel, stainless steel, or steel with epoxy coating. Grouted splice sleeves made of plain steel shall not be used with epoxy coated reinforcement. Grouted splice sleeves will be tested for the following parameters using California Test 670. The total slip shall be a maximum of:

#3 to #6	0.010 in.
#7 to #9	0.015 in.
#10 to #11	0.020 in.
#14	0.025 in.
#18	0.030 in.

The tensile strength of the splice shall be at least 125% of the yield strength of the reinforcing bar as tested according to ASTM A370.

In addition, the manufacturer shall submit test data as set forth in AASHTO LRFD 5.5.3.4 for grout-filled sleeves. The results shall show that the fatigue resistance of the splice meets the set criteria. The sample preparation, testing methodology, and data analysis shall all be conducted by a certified and independent laboratory using the same methodology as that used in NCHRP 10-35.

The grout shall be as supplied by the manufacturer of the splice sleeve, and shall be the same grout that appears on the Approved List.

**BASIS OF ACCEPTANCE.** Grouted Reinforcing Bar Splice Sleeve systems will be accepted on the basis of the manufacturer's name and location appearing on the Department's Approved List and a material certification that states the product conforms to this specification or, at the discretion of the Department, based on sampling and testing in accordance with the procedural directives of the Materials Bureau. *Buy America requirements apply.*

## §711-08 – ADMIXTURES- NON-CHLORIDE ACCELERATORS

Make the following changes to the Standard Specifications, dated May 1, 2008:

**Page 872** under **711-08 ADMIXTURES**, *delete* the paragraph **SCOPE**, and *replace* with the following:

“**SCOPE.** These specifications cover the material requirements for air-entraining, water-reducing and retarding, water-reducing (normal range and high range), and non-chloride accelerating admixtures used in the manufacture of Portland Cement concrete.”

**Page 874**, *after* paragraph **E. Length Change**, *add* the following:

“**Non-Chloride Accelerating Admixtures.** Non-chloride accelerating admixtures shall conform to the requirements outlined in ASTM C494 for Type C or Type E admixtures.”

**Page 874**, *delete* the paragraph **SAMPLING AND TESTING**, and *replace* with the following:

“**SAMPLING AND TESTING.** A one quart sample of admixture shall be submitted to the Materials Bureau by the manufacturer applying for approval, except that for Water-reducing (High Range) admixtures, two quarts will be required. The manufacturer shall submit information on the formulation of the product including the raw materials from which it is compounded, data from tests performed in accordance with these specifications and a description of the manufacturing process. Data from tests performed in accordance with ASTM C260 for air-entraining agents and ASTM C494 for water-reducing and retarding, water-reducing (normal range and high range), and non-chloride accelerating admixtures may be substituted.

The Department will test the submitted admixture sample according to written Department instructions. The test procedures are available from the Materials Bureau upon request.

The Department reserves the right to monitor the performance of any previously approved admixture. Samples of admixture may be taken from actual concrete operations and retested by the Materials Bureau.”

**Page 875**, *delete* the paragraph **BASIS OF ACCEPTANCE**, and *replace* with the following:

“**BASIS OF APPROVAL.** The approval of the admixture shall be based upon the submitted information and tests performed by the Materials Bureau. Upon approval by the Materials Bureau, the name of the product will be placed on the Approved List.

**BASIS OF ACCEPTANCE.** Admixtures will be accepted on the basis of the brand name appearing on the Approved List and the product containers plainly labeled with the brand name.

Any admixtures sampled from actual concrete operations and retested in the Materials Bureau shall give substantially the same results, at the same dosage rate, as the original tests. Any significant change will be cause for rejection of that material and may require a resubmission of the admixture by the manufacturer for a complete retest to determine specification compliance. The admixture may be withdrawn from the Approved List during the retest period.”

**SOIL EROSION AND SEDIMENT CONTROL**

Make the following changes to the Standard Specifications of May 1, 2008:

**Page 901, delete Class IV Soil Stabilizers** in its entirety and replace with the following:

**Class IV Soil Stabilizers.** Soil stabilizers are short-term duration, erosion control products. When used alone, they shall be used on slopes 1:2 or flatter. They shall not be used in channels or in areas of concentrated flow.

**Type A.** A soil binding system consisting of one of the following:

- Cementitious soil binder which is added to wood cellulose fiber mulch, a Bonded Fiber Matrix (BFM). Intended to form a thick, heavy-bodied crust or mat-like barrier that controls storm water and wind induced erosion. BFMs last up to six months and require a cure time up to 48 hours, without rain, to develop intimate soil contact.
- Soil stabilizing polymer which is added to wood cellulose fiber mulch, a Polymer Stabilized Fiber Matrix (PSFM). Intended to form a matrix that is designed to work directly with soil to maintain its stability by preserving existing soil structure, flocculating fine sediment being dislodged by storm water or wind, and to prevent splash erosion. PSFMs last up to six months and require a cure time up to 24 hours.

**Type B.** An anionic polyacrylamide (PAM) and calcium solution intended to reduce the erodibility of bare soils during construction activities or to enhance the performance of mulching on permanent slopes. Soil stabilizers, Type B, shall bond soil particles and shall effectively increase the soil particle size to 3/64 inch or larger. Soil stabilizers, Type B, shall reduce the movement of soil due to chemical bonding, thereby increasing the particle size rendering silt fence/sediment trapping devices more effective, and increase the water absorption of the soil.

**Type C.** A soil binder which may be made up of wood fibers, straw fibers, cotton fibers, interlocking fibers, polymers and hydro-colloid tackifiers, a Flexible Growth Medium (FGM) or Cotton Fiber Reinforcement Matrix (C-FRM). Intended to form a thick, heavy-bodied crust or mat-like barrier that controls storm water and wind induced erosion. FGMs/C-FRMs last up to a year and require no cure time to develop intimate soil contact.

Type A, B, and C soil stabilizers may be used alone or in combination with Class III, Types A and B Turf Reinforcement Materials where those products are used on slope applications.



**PAVEMENT MARKING MATERIALS**

Make the following changes to the Standard Specifications of May 1, 2008.  
 Page 1006, **Delete** Section 727 *Pavement Marking Materials* and **Replace** it with the following:

**SECTION 727 - PAVEMENT MARKING MATERIALS**

**727-01 EXTRUDED THERMOPLASTIC**

**SCOPE.** This specification covers the material requirements for thermoplastic that is extruded, in a molten state, onto a pavement surface. Following a surface application of reflective beads the resultant marking is a reflectorized stripe.

**MATERIAL REQUIREMENTS.** Unless otherwise noted, all samples are to be prepared and tested at an ambient temperature of 73°F ± 3°F.

**General.**

- Formulated for application at temperatures greater than 400°F.
- Show no significant breakdown or deterioration at 475°F.
- Pigment, beads and filler uniformly dispersed in the binder resin.
- Be free from all skins, dirt and foreign objects.
- Comply with the following requirements:

<b>TABLE 727-01-1 THERMOPLASTIC PROPERTIES</b>		
<b>Component</b>	<b>% by Weight</b>	
	<b>White</b>	<b>Yellow</b>
Binder	17.0 min	17.0 min.
Titanium Dioxide	10.0 min	---
Reflective Beads	30-40	30-40
Calcium Carbonate & Inert Fillers	43.0 max	*
Yellow Pigments	---	*

\* Amount and type of yellow pigment, calcium carbonate and inert fillers at the option of the manufacturer, providing the other composition requirements are met and the yellow pigment is lead chromate free.

**Physical Properties.**

- A. Color.** (ASTM D1535) When viewed under North Standard Daylight:  
 White: Approximate visual color match to Munsell Book Notation N 9.5/0.  
 Yellow: Approximate visual color match to Munsell Book Notation 10YR8/14.

- B. Yellowness Index.** (ASTM D1925 at 2° Observer angle and C Illuminate)  
 White thermoplastic: 0.12 maximum

- C. Softening Point.** (ASTM E28) Softening point: 194°F minimum.

## PAVEMENT MARKING MATERIALS

**D. Specific Gravity.** Between 1.8 and 2.2 as determined by a water displacement method at 77°F.

**E. Field Drying Time.** At 70°F, and thickness between 1/8 inch and 3/16 inch: Completely solid and showing no damaging effect from traffic after 10 minutes.

### Thermoplastic Primer.

- Specifically designed to enhance the bond of thermoplastic pavement markings to HMA and/or PCC pavements.
- Be either a one-component or two-component, cold- or hot-applied material of the type recommended by the manufacturer.
- Conform to current Federal, State and Local air pollution regulations, including those for the control (emission) of volatile organic compounds (VOC) as established by the U.S. EPA, and the NYSDEC.

**PACKAGING AND SHIPPING.** Shipped to the job site in strong, substantial containers, clearly marked with the following and including:

- Manufacturer's Name
- Name of Product
- Material Specification Number
- Lot/Batch Number
- Manufacture Date
- Expiration Date
- Quantity
- Two-component primer containers clearly identified as "Part A" and "Part B"
- Primers accompanied with written instructions for use

**BASIS OF APPROVAL.** Application for approval shall be submitted to the Materials Bureau by the manufacturer, accompanied by samples of each color (white and yellow) of the product and applicable glass beads in accordance with §727-05 *Glass Beads For Pavement Markings*, independent lab test results in accordance to this specification or in conjunction with the National Transportation Product Evaluation Program (NTPEP), and a certification that the product conforms to this specification.

Upon approval by the Materials Bureau, the product will be placed on the Approved List.

**BASIS OF ACCEPTANCE.** Extruded Thermoplastic will be accepted on the basis of the product appearing on the Approved List and a material certification that the product is the same as the one appearing on the Approved List and that it conforms to this specification.

## 727-02 REMOVABLE RAISED PAVEMENT MARKERS

**SCOPE.** This specification covers the material requirements for removable raised pavement markers for use as interim and temporary pavement markings.

### MATERIAL REQUIREMENTS

**General.** Removable raised pavement markers shall be:

Designed as single units consisting of an acrylic plastic or another type of durable casing, containing one or two reflective faces.

**PAVEMENT MARKING MATERIALS**

Approximately square in shape.  
 Capable of providing daytime delineation.  
 Adhere to HMA or PCC surfaces using adhesives and/or methods recommended by the manufacturer.  
 Removable from HMA and PCC pavements, intact or in substantially large pieces, without the use of heat, solvents, grinding or blasting.  
 Free from dirt or any other contaminants.

**Physical Properties.**

**A. Color.** (ASTM D1535) When viewed under North Standard Daylight:  
 White: Approximate visual color match to Munsell Book Notation N 9.5/0  
 Yellow: Approximate visual color match to Munsell Book Notation 10YR8/14

**B. Size.**  
 1. Casing. Minimum: 4 x 4 x 3/4 inch.  
 2. Reflective Lens. Minimum area of the reflective lens: 0.38 square inches.

**C. Reflectance.** Initial average reflectance values, when measured with incident light parallel to the base of the marker, at an observation angle of 0.2°.

<b>TABLE 727-02-1 REFLECTIVE MARKER LENSES REFLECTANCE</b>				
Color	White		Yellow	
Entrance Angle	0°	20°	0°	20°
Specific Intensity (cd/fc)	1.0	0.4	0.6	0.24

**NOTES:**

1. Observation Angle: The angle at the reflector between the observer's line of sight and the direction of light incident on the reflector.
2. Entrance Angle: The angle in the horizontal plane between the direction of incident light and the normal to the leading edge of reflective marker.
3. Specific Intensity: The luminous intensity (candelas) of returned light at the chosen observation and entrance angles for each footcandle of illumination at the reflector on a plane perpendicular to the incident light.
4. Photometric Test Procedure: The reflective marker to be tested shall be located with the center of the reflective lens at a distance of 5 feet from a uniformly bright light source, having an effective diameter of 0.2 in. The return of light shall be measured using an annular ring photocell (3/8 inch I.D. x 1/2 inch O.D.). The photocell shall be shielded to eliminate stray light. The distance from the light source center to the photocell center shall be 0.21 inches. If a test distance of other than 5 feet is used, the source and receiver shall be modified in the same proportion as the test distance.

**BASIS OF APPROVAL.** Application for approval shall be submitted to the Materials Bureau by the manufacturer, accompanied by samples of each color (white and yellow) of the product, independent lab test results in accordance with this specification or in conjunction with the National Transportation Product Evaluation Program (NTPEP), and certification that the product conforms to this specification. Additional field tests will be carried out in accordance with Materials Bureau Directives.

## PAVEMENT MARKING MATERIALS

Upon approval by the Materials Bureau, the product will be placed on the Approved List.

**BASIS OF ACCEPTANCE.** Removable Raised Pavement Markers for Interim Pavement Markings will be accepted on the basis of the product appearing on the Approved List and a material certification that the product is the same as the one appearing on the Approved List and that it conforms to this specification.

Removable Raised Pavement Markers used for Temporary Pavement Markings will be accepted on the basis of the product appearing on the Approved List. Upon request, the Contractor shall provide a material certification that the product is the same as the one appearing on the Approved List and that it conforms to this specification.

### 727-03 EPOXY PAINT

**SCOPE.** This specification covers the material requirements for epoxy pavement marking paint that is applied onto pavement, followed by a surface application of retroreflective beads for use as interim and permanent pavement markings.

### MATERIAL REQUIREMENTS

**General.** Epoxy paint shall be:

Formulated for use as a pavement marking material and for hot-spray application at elevated temperatures.

Two-component (Part A and Part B), 100% solids type system formulated and designed to provide a simple volumetric mixing ratio (e.g., two volumes of Part A to one volume of Part B).

VOC compliant and lead chromate free.

Use organic yellow pigments, Color Index Pigment Yellow 65 (C.I. 11740) and/or 74 (C.I. 11741).

Have a consistent target value of epoxy in Part A, based on ASTM D1652. Tested on a pigment free basis and calculated as the weight per epoxy equivalent (WPE).

Have a consistent total amine value of Part B based on ASTM D2074, or an alternate test method for determining the amine value specified by the manufacturer subject to the approval of the Director, Materials Bureau.

Display no bleeding on the surface upon which the paint is applied.

Conform to current Federal, State and Local air pollution regulations, including those for the control (emission) of volatile organic compounds (VOC) as established by the U.S. EPA and the NYSDEC.

### Physical Properties.

**A. % Pigment - Part A.** (ASTM D2371) Yellow: 23% minimum

White: 18% minimum

% TiO<sub>2</sub> (100% Purity) (NYS Test Method 727-20C) White: 16.5% minimum

**B. % Resin – Part A.** (ASTM D2371) Yellow: 70% - 77%

White: 75% - 82%

**C. Color.** (ASTM D1535) When viewed under North Standard Daylight, at a 15 ± 1 mil wet film thickness with no glass beads applied:

White: Approximate visual color match to Munsell Book Notation N 9.5/0

### PAVEMENT MARKING MATERIALS

Yellow: Approximate visual color match to Munsell Book Notation 10YR8/14 and within the following chromaticity coordinate limits when tested under ASTM E1347.

Coordinate	1	2	3	4
x	0.485	0.526	0.504	0.468
y	0.426	0.472	0.481	0.450

**D. Directional Reflectance.** (ASTM E1347) White: 84% minimum  
Yellow: 54% minimum

**E. Yellowness Index.** (ASTM D1925 at 2° Observer angle and C Illuminate)  
White Epoxy Paint: 0.12 maximum

**F. Drying Time – Laboratory.** (ASTM D711) Dry to no-pick-up time in 3 minutes maximum at an application rate of 15 ± 1 mils wet-film thickness and glass-sphere application rate of 20 lb/gal.

**G. Hardness.** (ASTM D2240) Samples cured for 72 to 96 hours prior to testing.  
Shore D Hardness: 75 - 100.

**H. Infrared Spectrophotometer Analysis.** (ASTM D2621) The spectrum of each component will be analyzed and maintained as a base record. Any subsequent samples taken from a Department contract must be a reasonable match to the original formulation spectrum accepted by the Materials Bureau for the Approved List.

**Placement Properties.** The material shall be capable of being placed using standard epoxy pavement marking equipment and have a maximum field no track time of 30 minutes when installed at 77°F.

**PACKAGING AND SHIPPING.** Shipped to the job site in strong, substantial containers, clearly marked with the following information:

- Manufacturer's Name
- Name of Product
- Material Specification Number
- Lot/Batch Number
- Date of Manufacture
- Expiration Date
- The Statement (as appropriate):  
“Part A Contains Pigment and Epoxy Resin,” or “Part B Contains Catalyst”
- Quantity

**BASIS OF APPROVAL.** Application for approval shall be submitted to the Materials Bureau by the manufacturer, accompanied by two 1/2 pint samples of each color (white and yellow) of Part A and one 1/2 pint of Part B for each color, independent lab test results in accordance with this specification or in conjunction with the National Transportation Product Evaluation Program (NTPEP), and certification that

## PAVEMENT MARKING MATERIALS

the product conforms to this specification. Additional field tests will be carried out in accordance with Materials Bureau Directives.

Upon approval by the Materials Bureau, the product will be placed on the Approved List.

**BASIS OF ACCEPTANCE.** Epoxy Paint for Permanent and/or Interim Pavement Markings will be accepted on the basis of the product appearing on the Approved List and a material certification that the product is the same as the one appearing on the Approved List and that it conforms to this specification.

Epoxy Paint used for Temporary Pavement Markings will be accepted on the basis of the product appearing on the Approved List. Upon request, the Contractor shall provide a material certification that the product is the same as the one appearing on the Approved List and that it conforms to this specification.

### 727-04 PERMANENT PAVEMENT TAPE

**SCOPE.** This specification covers the material requirements for preformed pavement marking tape that is applied to the pavement for use as permanent pavement markings.

**GENERAL.** Permanent pavement tape shall be:

Designed to provide immediate and continuous retroreflection.

Meet all the requirements of ASTM D4505.

Composed of a mixture of plastics or polymeric materials, resins, pigments, and reflective beads that are uniformly distributed throughout the thickness of the material.

Have a layer of reflective beads bonded to, or embedded in the top surface.

Pre-coated, on its bottom side, with a pressure-sensitive adhesive for adherence to HMA or PCC surfaces.

Of the specified dimension and shape with clean-cut, well-defined edges, of good appearance, and free of cracks or other defects.

Weather resistant and through normal traffic wear shall show no appreciable fading, lifting or shrinkage.

Capable of molding itself to the contours, breaks and faults of HMA or PCC surfaces.

Show no significant tearing, rollback, lifting or other signs of poor adhesion.

Free from dirt and any other contaminants.

**MATERIAL REQUIREMENTS.** Unless otherwise noted, all samples are to be prepared and tested at an ambient temperature of  $73^{\circ} \pm 3^{\circ}\text{F}$ .

**A. Color.** (ASTM D1535) When viewed under North Standard Daylight:

White: Approximate visual color match to Munsell Book Notation N 9.5/0

Yellow: Approximate visual color match to Munsell Book Notation 10YR8/14

**B. Thickness.** Preformed pavement marking tape shall be:

Uniform Cross Section: 60 mils minimum thickness.

Patterned (Variable Cross Section): 20 mils minimum thickness at the thinnest portions and 60 mils minimum thickness at the thickest portions.

The patterned top surface shall have approximately 50% of the surface area raised, and its design shall provide immediate and continuing retroreflection.

**C. Tensile Strength.** (ASTM D638) 40 psi minimum

Test specimens shall be Type II prepared by die cutting with Die C as specified in ASTM D412 Test

## PAVEMENT MARKING MATERIALS

Method A. The testing machine shall operate at a speed of 0.2 inches per minute. For calculating the tensile strength of patterned type material, the thickness measurements shall be taken in the thinnest portions of the cross sectional area.

**D. Elongation.** (ASTM D638) When tested in accordance with the conditions as specified for Tensile Strength: 15% minimum elongation

**Primer.** Primer shall be recommended by the manufacturer of the permanent tape and be compatible with the marking and surface the marking is being applied to.

Specifically designed to enhance the bond of the permanent tape to HMA and/or PCC pavements. Conform to current Federal, State and Local air pollution regulations, including those for the control (emission) of volatile organic compounds (VOC) as established by the U.S. EPA and the NYSDEC.

**PACKAGING AND SHIPPING.** Shipped to the job site in strong, substantial containers, clearly marked with the following and including:

- Manufacturer's Name
- Name of Product
- Material Specification Number
- Lot/Batch Number
- Manufacture Date
- Quantity
- Primers accompanied with written instructions for use
- Expiration Date

**BASIS OF APPROVAL.** Application for approval shall be submitted to the Materials Bureau by the manufacturer, accompanied by samples of each color (white and yellow) of the product, independent lab test results in accordance with this specification or in conjunction with the National Transportation Product Evaluation Program (NTPEP), and certification that the product conforms to this specification. Additional laboratory analysis and field tests will be carried out in accordance with Materials Bureau Directives.

Upon approval by the Materials Bureau, the product will be placed on the Approved List.

**BASIS OF ACCEPTANCE.** Permanent Pavement Tape and primer will be accepted on the basis of the products appearing on the Approved List and a material certification that the product is the same as the one appearing on the Approved List and that it conforms to this specification.

Permanent Pavement Tape and primer used for Temporary Pavement Markings will be accepted on the basis of the products appearing on the Approved List. Upon request, the Contractor shall provide a material certification that the product is the same as the one appearing on the Approved List and that it conforms to this specification.

### 727-05 GLASS BEADS FOR PAVEMENT MARKINGS

**SCOPE.** This specification covers the material requirements for retroreflective beads applied on top of thermoplastic, epoxy or traffic paint for use as pavement markings.

### PAVEMENT MARKING MATERIALS

**MATERIAL REQUIREMENTS.** Glass beads for pavement markings shall meet the requirements of AASHTO M247 and shall be:

Composed of glass that is highly resistant to traffic wear and to the effects of weathering.

Colorless, clean, transparent, free from milkiness or excessive air bubbles, and essentially free from surface scarring or scratching.

Silica content (ASTM C169): 60% minimum.

Refractive index: 1.50 when tested by the liquid immersion method at 77°F.

Show no tendency to absorb moisture in storage and shall remain free of clusters and hard lumps.

Flow freely from the dispensing equipment at any time when surface and atmospheric conditions are satisfactory for painting.

**A. Sphericity.** (ASTM D1155 Procedure A) Spherical in shape - 70% minimum, true spheres. Wet/Night Visibility Beads will be tested for roundness according to the procedural directives of the Materials Bureau.

**B. Gradation.** (ASTM D1214).

TABLE 727-05-1 GLASS SPHERE GRADATION (Standard Bead)				
Percent Passing by Weight				
Marking Type	Sieve Size			
	#20	#30	#50	#80
Epoxy	100	80-95	9-42	0-10
Traffic Paint	100	80-95	9-42	0-10
Thermoplastic	100	79-95	15-60	0-15

TABLE 727-05-2 GLASS SPHERE GRADATION (Wet/Night Visibility Bead)						
Percent Passing by Weight						
Marking Type	Sieve Size					
	#10	#12	#14	#16	#18	#20
Epoxy Wet/Night Reflective	100	95-100	75-95	10-47	0-7	0-2

**C. Coating.**

TABLE 727-05-3 GLASS SPHERE COATINGS	
Marking Type	Coating Type
Epoxy Wet/Night Reflective	Silane Type adherence coating designed to interact with and adhere to epoxy pavement markings.
Epoxy (Standard Bead)	Moisture-resistant coating or a dual purpose type coating (moisture-resistant and adherence).
Traffic Paint	
Thermoplastic (Drop on)	



## PAVEMENT MARKING MATERIALS

### **D. Moisture Resistance.** AASHTO M 247 Section 5.3.2

**PACKAGING AND SHIPPING.** Shipped to the job site in waterproof plastic lined burlap or plastic lined paper bags with the following information clearly marked on the packages:

- Manufacturer's Name
- Name of Product
- Size/Type/Coating
- Material Specification Number
- Lot/Batch Number
- Manufacture Date
- Quantity/Weight of Material

**BASIS OF APPROVAL.** Application for approval shall be submitted to the Materials Bureau by the manufacturer, accompanied by one 50 lb bag sample of the product, independent lab test results in accordance with this specification and certification that the product conforms to this specification.

Upon approval by the Materials Bureau, the product will be placed on the Approved List.

**BASIS OF ACCEPTANCE.** Glass Beads for Pavement Markings will be accepted on the basis of the product appearing on the Approved List and a material certification that the product is the same as the one appearing on the Approved List and that it conforms to this specification.

Glass Beads for Pavement Markings used for Temporary Pavement Markings will be accepted on the basis of the product appearing on the Approved List. Upon request, the Contractor shall provide a material certification that the product is the same as the one appearing on the Approved List and that it conforms to this specification.

### **727-06 REMOVABLE PAVEMENT TAPE**

**SCOPE.** This specification covers the material requirements for removable pavement marking tape and masking tape for use as interim and temporary pavement markings.

### **MATERIAL REQUIREMENTS.**

**General.** Removable pavement tape shall be:

Composed of a mixture of plastics or polymeric materials, resins, pigments.

Have on its bottom side, a pre-applied, pressure-sensitive adhesive for adherence to HMA or PCC surfaces.

Of the specified dimension and shape with clean-cut, well defined-edges, of good appearance, and free of cracks or other defects.

Weather resistant and through normal traffic wear shall show no appreciable fading, lifting or shrinkage.

Capable of molding itself to the contours, breaks and faults of HMA or PCC surfaces.

Show no significant tearing, rollback, lifting or other signs of poor adhesion.

Removable from HMA and PCC pavements, intact or in substantially large pieces, without the use of heat, solvents, grinding or blasting, and leaving minimal permanent marks, scars or damage to the pavement surface after removal.

Be free from dirt and any other contaminants.

## PAVEMENT MARKING MATERIALS

### Retroreflective Tape.

Designed to provide immediate and continuous retroreflection.

Composed of a mixture of plastics or polymeric materials, resins, pigments, and reflective beads that are uniformly distributed throughout the thickness of the material.

Have a layer of reflective beads bonded to, or embedded in the top surface.

Meet the following requirements:

**A. Color:** (ASTM D1535) When viewed under North Standard Daylight:

White: Approximate visual color match to Munsell Book Notation N 9.5/0

Yellow: Approximate visual color match to Munsell Book Notation 10YR 8/14 and be within the following chromaticity coordinate limits when tested under ASTM E1347.

TABLE 727-06-1 CHROMATICITY COORDINATES				
Coordinate	1	2	3	4
x	0.485	0.526	0.504	0.468
y	0.426	0.472	0.481	0.450

**B. Reflectance:**

TABLE 727-06-2 PREFORMED TAPE REFLECTANCE REQUIREMENTS				
Color	White		Yellow	
Observation Angle	0.2°	0.5°	0.2°	0.5°
Specific Luminance (mcd/ft <sup>2</sup> /fc)	1770	1270	1310	810

**Masking Tape.** Masking tape shall be:

Specifically designed for use to temporarily cover existing pavement markings.

Consist of durable, nonreflective, pliant polymer tape on a reinforced, conformable backing, pre-coated with a pressure-sensitive adhesive

Capable of adhering to existing pavement markings, asphalt pavement and Portland cement concrete pavement without the use of heat, solvents, additional adhesives or other means.

Be substantially similar in color to the pavement surface with a flat matte finish and textured, skid resistant surface.

**BASIS OF APPROVAL.** Application for approval shall be submitted to the Materials Bureau by the manufacturer, accompanied by samples of each color (white, yellow, black/grey) of the product, independent lab test results in accordance with this specification or in conjunction with the National Transportation Product Evaluation Program (NTPEP), and certification that the product conforms to this specification. Additional laboratory analysis and field tests will be carried out in accordance with Materials Bureau Directives.

Upon approval by the Materials Bureau, the product will be placed on the Approved List.

**BASIS OF ACCEPTANCE.** Removable Pavement Tape used for Interim Pavement Markings will be accepted on the basis of the product appearing on the Approved List and a material certification that the product is the same as the one appearing on the Approved List and that it conforms to this specification.

**PAVEMENT MARKING MATERIALS**

Removable Pavement Tape used for Temporary Pavement Markings will be accepted on the basis of the product appearing on the Approved List. Upon request, the Contractor shall provide a material certification that the product is the same as the one appearing material on the Approved List and that it conforms to this specification.

**727-07 REMOVABLE WET-NIGHT REFLECTIVE TAPE**

**SCOPE.** This specification covers the material requirements for removable wet-night reflective tape for use as interim and temporary pavement markings.

**MATERIAL REQUIREMENTS.**

**General.** Removable Wet-Night reflective tape shall be:

Designed to provide immediate and continuous retroreflection in day and night as well as dry and wet conditions.

Composed of a mixture of durable plastics or polymeric materials, resins, pigments, and reflective beads that are uniformly distributed throughout the thickness of the material.

Pre-coated, on its bottom side, with a pressure-sensitive adhesive.

Capable of adhering to existing pavement markings, asphalt pavement and Portland cement concrete pavement without the use of heat, solvents, additional adhesives or other means.

Of the specified dimension and shape with clean-cut, well-defined edges, of good appearance, and free of cracks or other defects.

Weather resistant and through normal traffic wear shall show no appreciable fading, lifting or shrinkage.

Capable of molding itself to the contours, breaks and faults of HMA or PCC surfaces.

Show no significant tearing, rollback, lifting or other signs of poor adhesion.

Removable from HMA and PCC pavements, intact or in substantially large pieces, without the use of heat, solvents, grinding or blasting, and leaving minimal permanent marks, scars or damage to the pavement surface after removal.

Have a layer of reflective beads bonded to, or embedded in the top surface.

Free from dirt and any other contaminants.

Meet the following requirements:

**Physical Properties.**

**A. Color:** (ASTM D1535) When viewed under North Standard Daylight:

White: Approximate visual color match to Munsell Book Notation N 9.5/0 and be within the following daytime chromaticity coordinates (dry) when tested under ASTM E1347.

<b>TABLE 727-07-1 WHITE CHROMATICITY COORDINATES</b>				
Coordinate	1	2	3	4
x	0.355	0.305	0.285	0.335
y	0.355	0.305	0.325	0.375

Yellow: Approximate visual color match to Munsell Book Notation 10YR 8/14 and be within the following daytime chromaticity coordinates (dry) when tested under ASTM E1347.

## PAVEMENT MARKING MATERIALS

Coordinate	1	2	3	4
x	0.560	0.460	0.420	0.490
y	0.440	0.400	0.440	0.510

**B. Retroreflectivity.** Wet: ASTM E2176 and ASTM E2177  
Dry: ASTM E1710

<b>Entrance Angle: 88.76° Observation Angle: 1.05°</b>				
Color	White		Yellow	
Condition	Dry	Wet	Dry	Wet
Retroreflectivity [mcd/ft <sup>2</sup> /fc]	500	250	300	200

**BASIS OF APPROVAL.** Application for approval shall be submitted to the Materials Bureau by the manufacturer, accompanied by samples of each color (white and yellow) of the product, independent lab test results in accordance with this specification or in conjunction with the National Transportation Product Evaluation Program (NTPEP), and certification that the product conforms to this specification. Additional laboratory analysis and field tests will be carried out in accordance with Materials Bureau Directives.

Upon approval by the Materials Bureau, the product will be placed on the Approved List.

**BASIS OF ACCEPTANCE.** Removable Wet-Night Reflective Tape used for Interim Pavement Markings will be accepted on the basis of the product appearing on the Approved List and a material certification that the product is the same as the one appearing on the Approved List and that it conforms to this specification.

Removable Wet-Night Reflective Tape used for Temporary Pavement Markings will be accepted on the basis of the product appearing on the Approved List. Upon request, the Contractor shall provide a material certification that the product is the same as the one appearing on the Approved List and that it conforms to this specification.

**727-08 PERMANENT WET-NIGHT REFLECTIVE TAPE**

**SCOPE.** This specification covers the material requirements for permanent wet-night pavement marking tape for use as permanent pavement markings.

**MATERIAL REQUIREMENTS.** Unless otherwise noted, all samples are to be prepared and tested at an ambient temperature of 73° ± 3°F.

**General.** Permanent wet-night reflective tape shall be:

Designed to provide immediate and continuous retroreflection in day and night as well as dry and wet conditions.

Composed of a mixture of plastics or polymeric materials, resins, pigments, and reflective beads that are uniformly distributed throughout the thickness of the material.

**PAVEMENT MARKING MATERIALS**

Have a layer of reflective beads bonded to, or embedded in the top surface. Pre-coated, on its bottom side, with a pressure-sensitive adhesive for adherence to HMA or PCC surfaces. Of the specified dimension and shape with clean-cut, well-defined edges, of good appearance, and free of cracks or other defects.

Weather resistant and through normal traffic wear shall show no appreciable fading, lifting or shrinkage.

Capable of molding itself to the contours, breaks and faults of HMA or PCC surfaces.

Show no significant tearing, rollback, lifting or other signs of poor adhesion.

Free from dirt and any other contaminants.

**Physical Properties.**

**A. Color:** (ASTM D1535) When viewed under North Standard Daylight:

White: Approximate visual color match to Munsell Book Notation N 9.5/0 and be within the following daytime chromaticity coordinates (dry) when tested under ASTM E1347.

<b>TABLE 727-08-1 WHITE CHROMATICITY COORDINATES</b>				
Coordinate	1	2	3	4
x	0.355	0.305	0.285	0.335
y	0.355	0.305	0.325	0.375

Yellow: Approximate visual color match to Munsell Book Notation 10YR 8/14 and be within the following daytime chromaticity coordinates (dry) when tested under ASTM E1347.

<b>TABLE 727-08-2 YELLOW CHROMATICITY COORDINATES</b>				
Coordinate	1	2	3	4
x	0.560	0.460	0.420	0.490
y	0.440	0.400	0.440	0.510

**B. Retroreflectivity.**

Wet: ASTM E2176 and ASTM E2177

Dry: ASTM E1710

<b>TABLE 727-08-3 MINIMUM INITIAL RETROREFLECTIVITY</b>		
<b>Entrance Angle: 88.76° Observation Angle: 1.05°</b>		
Color	White	Yellow
Retroreflectivity (mcd/ft <sup>2</sup> /cd)	750	450

**C. Thickness.**

Uniform Cross Section: 60 mils minimum thickness

Patterned (Variable Cross Section): 20 mils minimum thickness at the thinnest portions and 60 mils minimum thickness at the thickest portions.

The patterned top surface shall have approximately 50% of the surface area raised, and its design shall provide immediate and continuing retroreflection.

**D. Friction Resistance.** (ASTM E303) Friction resistance: 45 BPN minimum.

## PAVEMENT MARKING MATERIALS

### **E. Tensile Strength.** (ASTM D638) Tensile strength: 40 psi minimum

Test specimens shall be Type MII prepared by die cutting with Die C as specified in ASTM D412, Test Method A. The testing machine shall operate at a speed of 0.2 inches per minute. For calculating the tensile strength of patterned type material, the thickness measurements shall be taken in the thinnest portions of the cross sectional area.

**F. Elongation.** (ASTM D638) 15% minimum elongation when tested in accordance with the conditions as specified for Tensile Strength.

### **Primer.** Primer shall be:

Be recommended by the manufacturer of the preformed pavement marking and be compatible with the marking and surface the marking is being applied to.

Specifically designed to enhance the bond of the preformed pavement markings to HMA and/or PCC pavements.

Conform to current Federal, State and Local air pollution regulations, including those for the control (emission) of volatile organic compounds (VOC) as established by the U.S. EPA and the NYSDEC.

**PACKAGING AND SHIPPING.** Shipped to the job site in strong, substantial containers, clearly marked with the following and including:

- Manufacturer's Name
- Name of Product
- Material Specification Number
- Lot/Batch Number
- Manufacture Date
- Quantity
- Primers accompanied with written instructions for use
- Expiration Date

**BASIS OF APPROVAL.** Application for approval shall be submitted to the Materials Bureau by the manufacturer, accompanied by samples of each color (white and yellow) of the product, independent lab test results in accordance with this specification or in conjunction with the National Transportation Product Evaluation Program (NTPEP), and certification that the product conforms to this specification. Additional laboratory analysis and field tests will be carried out in accordance with Materials Bureau Directives.

Upon approval by the Materials Bureau, the product will be placed on the Approved List.

**BASIS OF ACCEPTANCE.** Permanent Wet Night Reflective Tape and primer will be accepted on the basis of the product appearing on the Approved List and a material certification that the product is the same as the one appearing on the Approved List and that it conforms to this specification.

Permanent Wet-Night Reflective Tape and primer used for Temporary Pavement Markings will be accepted on the basis of the product appearing on the Approved List. Upon request, the Contractor shall provide a material certification that the product is the same as the one appearing on the Approved List and that it conforms to this specification.

### **727-09 TRAFFIC PAINT**

**PAVEMENT MARKING MATERIALS**

**SCOPE.** This specification covers the material requirements for waterborne and solventborne paints that are applied onto pavement, followed by a surface application of retroreflective beads for use as temporary, interim and permanent pavement markings.

**MATERIAL REQUIREMENTS.**

**General.** Traffic paint shall be:

Formulated for use as a pavement marking material.

Be VOC compliant and lead chromate free.

Yellow paints must use organic yellow pigments Color Index Pigment Yellow 65 (C.I. 11740) and/or 74 (C.I. 11741).

Display no bleeding on the surface upon which the paint is applied.

Conform to current Federal, State and Local air pollution regulations, including those for the control (emission) of volatile organic compounds (VOC) as established by the U.S. EPA, and the NYSDEC.

**Physical Properties.**

Traffic paint for permanent and Interim Pavement Markings shall conform to the requirements of paragraphs A through L below. Traffic paint for Temporary Pavement Markings shall conform to the following paragraphs: B. *Color*; C. *Directional Reflectance*; D. *Yellowness Index*; E. *Drying Time*; F. *Viscosity*; and G. *Dry Opacity*.

**A. Composition.**

% Pigment. (ASTM D3723) 58.0% – 62.0%

% Total Solids. (ASTM D3723) 76.0 % minimum

% Vehicle Non-Volatile. (ASTM D3723) 43.0 % minimum

The manufacturers certified organic yellow pigment content shall be used to determine the final laboratory test results for: total pigment (%), and for nonvolatile vehicle (%). The Department reserves the right to validate the manufacturers "certified" organic yellow pigment content through outside, independent laboratory testing.

**B. Color.** (ASTM D1535) When viewed under North Standard Daylight at a 15 ± 1 mils wet film thickness with no glass beads applied:

White: Approximate visual color match to Munsell Book Notation N 9.5/0.

Yellow: Approximate visual color match to Munsell Book Notation 10YR 8/14 and within the following chromaticity coordinate limits when tested under ASTM E1347.

<b>TABLE 727-09-1 CHROMATICITY COORDINATES</b>				
Coordinate	1	2	3	4
x	0.485	0.517	0.492	0.468
y	0.426	0.462	0.471	0.450

**C. Directional Reflectance** (ASTM E1347)

White: 84% minimum

Yellow: 54% minimum

**D. Yellowness Index.** (ASTM D1925 at 2°Observer angle and C Illuminate)

## PAVEMENT MARKING MATERIALS

White Traffic Paint: 0.12 maximum.

**E. Viscosity.** (ASTM D562 Procedures B) 75 – 95 Kreb Units at 77°F

**F. Dry Opacity.** (ASTM D2805) 0.95 minimum contrast ratio  
Application at 3 1/2 inches wide, wet-film thickness of 5 mils to white and black contrast panels matching Lenta Form 5C or equivalent. Dry time of 1 hour minimum.

**G. Abrasion Resistance.** (ASTM D4060) Four plate samples for each lot will be prepared for testing on the Taber Abaser. The paint will be sprayed on steel plates, or applied by other suitable means so as to ensure a nominal 15 mil wet film thickness on each plate. Plates will be cured at standard laboratory temperature and humidity for 2 to 24 hours. The paint abrasion plates will be cleaned, dressed, and baked at 221°F for 18 hours. After baking, the plates will be allowed to cool in a desiccator for one hour and then weighed. The plates will be abraded for 1000 cycles on the Taber Abraser. The Taber Abraser will be operated with 1.10 lb weights and CS 10 wheels on the machine.

After abrading, the samples will be cleaned with a soft brush, placed in a desiccator for one hour and weighed again. The average weight loss for the four plates shall not exceed 0.00176 oz.

**H. Flexibility.** (Federal Specification TT-P-1952B Section 4.5.4) No cracking or flaking visible. Determine flexibility in accordance with Method B of ASTM D522.

**I. Freeze-Thaw Stability.** (Federal Specification TT-P-1952b, Section 4.5.7)  
No coagulation or change in consistency (ASTM D562) greater than 15 Kreb Units.

**J. Heat Stability.** (Federal Specification TT-P-1952b, Section 4.5.8) Waterborne only. No coagulation, discoloration or change in consistency (ASTM D562) greater than 15 Kreb Units when tested in an oven at 120° ± 2°F.

### **K. Infrared Spectrophotometer Analysis.**

Waterborne: (ASTM D3168) Solventborne: (ASTM D2621)

The spectrum of the paint will be analyzed and maintained as a base record. Any subsequent samples taken from a Department contract must be a reasonable match to the original formulation spectrum accepted by the Materials Bureau for the Approved List.

### **Placement Properties.**

The material shall be placed using standard traffic paint application equipment and have a maximum field no track time of 3 minutes when installed at 77°F.

**PACKAGING AND SHIPPING.** Shipped to the job site in strong, substantial containers. Individual containers plainly marked with the following information:

- Manufacturer's Name
- Name of Product
- Material Specification Number
- Lot/Batch Number
- Test Number
- Manufacture Date



**PAVEMENT MARKING MATERIALS**

- Expiration Date
- Quantity

**BASIS OF APPROVAL.** Application for approval shall be submitted to the Materials Bureau by the manufacturer, accompanied by eight 1 pint samples of each color (white and yellow) of the product, independent lab test results in accordance with this specification or in conjunction with the National Transportation Product Evaluation Program (NTPEP), and certification that the product conforms to this specification. Additional field tests will be carried out in accordance with Materials Bureau Directives.

Upon approval by the Materials Bureau, the product will be placed on the Approved List.

**BASIS OF ACCEPTANCE.** Traffic Paint for permanent and Interim Pavement Markings will be accepted on the basis of the product appearing on the Approved List and a material certification that the product is the same as the one appearing on the Approved List and that it conforms to this specification.

Traffic Paint used for Temporary Pavement Markings need not appear on the Approved List. Upon request, the Contractor shall provide a material certification that the product conforms to this specification.

**D262100**  
**SHEET GASKET (TREATED BOTH SIDES)**

Make the following changes to the Standard Specifications dated May 1, 2008:

Page 1021 **Delete** §728-06 Sheet Gasket (Treated Both Sides) in its entirety and **Replace** it with the following:

**728-06 SHEET GASKET (TREATED BOTH SIDES)**

**SCOPE.** This specification covers the material requirements for sheet gasket, treated both sides with a parting agent to prevent adhesion to working surfaces. This material is used as a bond breaker and sliding surface in bridge construction.

**MATERIAL REQUIREMENTS.** The sheet gasket shall have a nominal 1/16 inch thickness and shall be treated on both sides with a parting agent. The material shall meet the following requirements:

<b>TABLE 728-06-1 SHEET GASKET REQUIREMENTS</b>		
<b>Property</b>	<b>Test Method</b>	<b>Requirement</b>
Water absorption, %	Prepare 3 samples (2x2 inches, 1/16±1/32 inch thick). Record initial weight of the specimen. Immerse the samples in a distilled water tank for 24 hrs at room temperature. Take out the samples and dry it with a dry cloth, then record final weight. Use the difference in weight to calculate the water absorption %.	25.0 Maximum
Coefficient of static friction	ASTM D1894	0.36 Maximum
Coefficient of kinetic friction	ASTM D1894	0.24 Maximum
Tensile strength, psi in the weakest direction	ASTM F152, Type 2	1200 Minimum

**BASIS OF ACCEPTANCE.** Sheet Gaskets will be accepted on the basis of the product appearing on the Department's Approved List.

Make the following changes to the Standard Specifications of May 1, 2008:  
Page 1021, **Delete** Section 729 *Temporary Traffic Control Devices* and **Replace** it with the following:

## **SECTION 729 – TEMPORARY TRAFFIC CONTROL DEVICES**

### **729-01 DRUMS**

**SCOPE.** This specification covers the material, fabrication, and performance requirements for traffic drums. Drums are defined by FHWA as a Category I device.

**MATERIAL REQUIREMENTS.** Drums shall conform to the requirements of the MUTCD, shall be NCHRP 350 or MASH approved and shall be orange plastic, one-piece or two-piece construction, with a closed top. Drums shall be a minimum of 18 inches in diameter (visible from all directions), a minimum of 36 inches in height. Drums shall have a maximum weight of 75 lbs., including ballast. Two-piece drums shall consist of a base no more than 4 inches in height and an upper section. The base and upper section of two-piece drums shall be designed as a unit. One-piece drums shall include a base ring or elongation designed to hold ballast. The base and/or any nonflexible portion of the drum shall not extend more than 2 inches above the pavement surface.

Drums shall have 4 horizontal circumferential stripes of reflective sheeting a minimum of 4 inches wide, of alternating orange and white, starting with orange on the top. The top edge of the upper band shall be a maximum of 2 inches from the top edge of the drum. The space between stripes shall not exceed 2 inches.

Reflective sheeting shall conform to ' 730-05 *Reflective Sheeting* ASTM Type I (Class A), ASTM Type III (Class B), or higher. Reflective sheeting shall be firmly bonded to the drum with an adhesive; mechanical fasteners to bond reflective sheeting to the drum will not be allowed.

**BASIS OF ACCEPTANCE.** Upon request, the Contractor shall provide a material certification that the product conforms to this specification.

### **729-02 CONES**

**SCOPE.** This specification covers the material, fabrication, and performance requirements for traffic cones. Cones are defined by FHWA as a Category I device.

**MATERIAL REQUIREMENTS.** Cones shall conform to the requirements of the MUTCD, shall be NCHRP 350 or MASH approved and shall be orange rubber or plastic. Cones shall have a maximum weight of 20 lbs, including ballast.

Standard cones shall be approximately 28 inches in height with a minimum conical bottom width of 10 inches. Standard cones shall have two horizontal circumferential stripes of white reflective sheeting, the upper a minimum of 6 inches wide, with the upper edge 3 to 4 inches from the top of the cone, and the lower a minimum of 4 inches wide with the upper edge approximately 2 inches below the upper stripe.

Tall cones shall be approximately 36 inches in height with a minimum conical bottom width of 10 inches. Tall cones shall have two horizontal circumferential stripes of white reflective sheeting, the upper a minimum of 6 inches wide, with the upper edge 3 to 4 inches from the top of the cone, and the lower a minimum of 4 inches wide with the upper edge approximately 2 inches below the upper stripe.

Extra tall cones shall be a minimum of 42 inches in height with a minimum conical bottom width of 7 inches. Extra tall cones shall have a minimum of four horizontal circumferential stripes of reflective sheeting from 4 to 6 inches wide, of alternating orange and white starting with orange on the top. The upper edge of the sheeting shall be 4 inches from the top of the cone. Nonreflective spaces between the stripes shall not exceed 3 inches wide.

Reflective sheeting shall conform to ' 730-05 *Reflective Sheeting* ASTM Type I (Class A), ASTM Type III (Class B) or higher. Reflective sheeting shall be firmly bonded to the cone with adhesive.

**BASIS OF ACCEPTANCE.** Upon request, the Contractor shall provide a material certification that the product conforms to this specification.

**729-03 TEMPORARY TUBULAR MARKERS**

**SCOPE.** This specification covers the material, fabrication, and performance requirements for tubular markers. Tubular markers are defined by FHWA as a Category I device.

**MATERIAL REQUIREMENTS.** Tubular markers shall conform to the requirements of the MUTCD, shall be NCHRP 350 or MASH approved and shall be orange, with a minimum height of 36 inches and a minimum outside diameter of 2 inches. Tubular markers shall be circular or elliptical in cross section. Tubular markers shall have a maximum weight of 12 lbs, not including a mounting base.

The markers shall have two horizontal circumferential stripes of white reflective sheeting a minimum of 3 inches wide. The top edge of the upper band shall be a maximum of 2 inches from the top of the marker. The space between shall not exceed 6 inches.

Reflective sheeting shall conform to ' 730-05 *Reflective Sheeting* ASTM Type I (Class A), ASTM Type III (Class B) or higher. The sheeting shall be bonded to the post with a precoated, pressure-sensitive adhesive or a tack-free, heat-activated adhesive. Mechanical fasteners to bond reflective sheeting to the post will not be allowed.

For free-standing tubular markers, the base and/or any nonflexible portion of the marker shall not be more than 2 inches in height.

For tubular markers fastened to pavement, the bonding system used to shall be a fast-setting chemical compound, mastic-type material, or mechanical fastener capable of fixing the tubular marker to either concrete or asphalt pavement. The bonding system shall not present a hazard to traffic if the tubular marker or base unit becomes unfixed from the pavement.

**BASIS OF ACCEPTANCE.** Upon request, the Contractor shall provide a material certification that the product conforms to this specification.

**729-04 VERTICAL PANELS**

**SCOPE.** This specification covers the material, fabrication, and performance requirements for vertical panels. Vertical panels are defined by FHWA as a Category II device.

**MATERIAL REQUIREMENTS.** Vertical panels shall conform to the requirements of the MUTCD, shall be NCHRP 350 or MASH approved and shall be constructed of plastic, aluminum, or other lightweight materials. Vertical panels shall be supported by a base capable of maintaining the panel in an upright position and in the proper position and orientation.

Vertical panels shall have 4 to 6 inch wide diagonal stripes of alternating orange and white reflective sheeting, sloping downward at an angle of 45° toward the side on which traffic is to pass. Vertical panels which are 36 inches and larger shall have 6 inch wide diagonal stripes.

Standard vertical panels shall be a minimum of 24 inches in height and a minimum of 8 inches in width. The top of the panel shall be mounted a maximum of 36 inches high. Support posts for standard vertical panels shall not be located on the traffic face of the panel.

Oversized vertical panels shall be a minimum of 36 inches in height and have a minimum reflective area of 2.0 square feet.

Reflective sheeting shall conform to ' 730-05 *Reflective Sheeting* ASTM Type I (Class A), ASTM Type III (Class B) or higher.

**BASIS OF ACCEPTANCE.** Upon request, the Contractor shall provide a material certification that the product conforms to this specification.

**729-05 STOP/SLOW PADDLES**

**SCOPE.** This specification covers the material requirements for stop/slow paddles.

**MATERIAL REQUIREMENTS.** Stop/slow paddles shall conform to the requirements of the MUTCD and shall be constructed of plastic, aluminum, or other lightweight materials. Stop/slow paddles shall be a minimum of 24 inches wide and shall be mounted on a support staff with a minimum height of 6 feet to the bottom of the panel. Reflective sheeting shall conform to ' 730-05 *Reflective Sheeting* ASTM Type IX (Class E).

**BASIS OF ACCEPTANCE.** Upon request, the Contractor shall provide a material certification that the product conforms to this specification.

### **729-06 TYPE I CONSTRUCTION BARRICADES**

**SCOPE.** This specification covers the material, fabrication, and performance requirements for Type I construction barricades. Type I construction barricades are defined by FHWA as a Category II device.

**MATERIAL REQUIREMENTS.** Type I construction barricades shall conform to the requirements of the MUTCD and shall be NCHRP 350 or MASH approved. Type I construction barricades shall be constructed of an A-frame with a single rail panel 8 to 12 inches wide and a minimum of 24 inches long. Rails on barricades used on expressways and other high-speed roadways shall have an area of at least 2.0 square feet. The top of the upper panel shall be mounted at a minimum height of 36 inches. Barricade frames shall be designed to maintain the proper orientation and location of the device during windy conditions. Non-rigid ballast may be placed on the frame, close to the ground, to hold the barricade in position, and shall not obscure the view of the rail panels to approaching traffic.

Barricade rail panels shall have 4 inch wide reflective, alternating orange and white diagonal stripes sloping at an angle of 45°. Reflective sheeting shall conform to ' 730-05 *Reflective Sheeting* ASTM Type I (Class A), ASTM Type III (Class B), or higher.

**BASIS OF ACCEPTANCE.** Upon request, the Contractor shall provide a material certification that the product conforms to this specification.

### **729-07 TYPE II CONSTRUCTION BARRICADES**

**SCOPE.** This specification covers the material, fabrication, and performance requirements for Type II construction barricades. Type II construction barricades are defined by FHWA as a Category II device.

**MATERIAL REQUIREMENTS.** Type II construction barricades shall conform to the requirements of the MUTCD and shall be NCHRP 350 or MASH approved. Type II construction barricades shall be constructed of a frame with two rail panels 8 to 12 inches wide and a minimum of 24 inches long. Rails on barricades used on expressways and other high-speed roadways shall have an area of at least 2.0 square feet. The top of the upper panel shall be mounted at a minimum height of 36 inches. Barricade frames shall be designed to maintain the proper orientation and location of the device during windy conditions. Non-rigid ballast may be placed on the frame, close to the ground, to hold the barricade in position, and shall not obscure the view of the rail panels to approaching traffic.

Barricade rail panels shall have 4 to 6 inch wide reflective, alternating orange and white diagonal stripes sloping at an angle of 45°. Barricade rail panels 36 inches and longer shall have 6 inch wide stripes. Reflective sheeting shall conform to ' 730-05 *Reflective Sheeting* ASTM Type I (Class A), ASTM Type III (Class B) or higher.

**BASIS OF ACCEPTANCE.** Upon request, the Contractor shall provide a material certification that the product conforms to this specification.

### **729-08 TYPE III CONSTRUCTION BARRICADES**

**SCOPE.** This specification covers the material, fabrication, and performance requirements for Type III construction barricades. Type III construction barricades are defined by FHWA as a Category II device.

**MATERIAL REQUIREMENTS.** Type III construction barricades shall conform to the requirements of the MUTCD and shall be NCHRP 350 or MASH approved. Type III construction barricades shall be constructed of a frame with

## D262100

### TEMPORARY TRAFFIC CONTROL DEVICES

three rail panels 8 to 12 inches wide and a minimum of 48 inches long. The top of the upper panel shall be mounted at a minimum height of 60 inches. Barricade frames shall be designed to maintain the proper orientation and location of the device during windy conditions. Nonrigid ballast may be placed on the frame, close to the ground, to hold the barricade in position, and shall not obscure the view of the rail panels to approaching traffic.

Barricade rail panels shall have 6 inch wide reflective alternating orange and white diagonal stripes sloping at an angle of 45°. Reflective sheeting shall conform to '730-05 *Reflective Sheeting* ASTM Type I (Class A), ASTM Type III (Class B) or higher.

Warning lights, when used, shall be securely mounted directly to the barricade frame, above the top rail, using a bolt, nut, and washer of sufficient strength to ensure that the light does not detach if impacted by a vehicle, and no part of the light or wiring shall cover the face of the rail. Batteries shall be placed at ground level, except that integral batteries weighing a maximum of 7 lbs may be mounted on the barricade frame. Warning lights shall not be attached to the barricade rail.

**BASIS OF ACCEPTANCE.** Upon request, the Contractor shall provide a material certification that the product conforms to this specification.

#### 729-09 TEMPORARY SIGN SUPPORTS

**SCOPE.** This specification covers the material, fabrication, and performance requirements for temporary sign supports. Temporary sign supports are defined by FHWA as a Category II device.

**MATERIAL REQUIREMENTS.** Temporary sign supports shall conform to the requirements of the MUTCD and shall be constructed in accordance with the Standard Sheets or shall be commercially manufactured, temporary sign supports that are NCHRP 350 or MASH approved.

**BASIS OF ACCEPTANCE.** Upon request, the Contractor shall provide a material certification that the product conforms to this specification.

#### 729-10 TEMPORARY IMPACT ATTENUATORS - REDIRECTIVE

**SCOPE.** This specification covers the material and performance requirements for temporary impact attenuators. Temporary impact attenuators are defined by FHWA as a Category III device.

**MATERIALS REQUIREMENTS.** Temporary impact attenuators shall be NCHRP 350 or MASH approved as a redirective, non-gating device. Temporary impact attenuators that use liquid or other materials as a filler or to provide ballast will be evaluated for potential environmental impacts and/or seasonal limitations. Temporary impact attenuators meeting the requirements of NCHRP 350 or MASH Test Level 2 are acceptable only as Test Level 2 devices. A Temporary impact attenuator accepted as a Test Level 3 device is also acceptable as Test Level 2 device. Temporary impact attenuators will be approved for use in shielding an object of a maximum width as specified in the Approved List, and specific configurations may be approved for maximum speeds. Approach ends of Temporary impact attenuators shall have impact attenuator markings in accordance with the MUTCD.

Concrete Grouting Material	701-05
Anchoring Materials - Chemically Curing	701-07

If a temporary foundation slab is required, concrete shall be Class A concrete conforming to Section 501 *Portland Cement Concrete - General*; reinforcing steel shall conform to §709-01 *Bar Reinforcement, Grade 420*.

**BASIS OF APPROVAL.** Manufacturers or material suppliers desiring to have Test Level 2 or Test Level 3 temporary impact attenuators approved shall prepare and submit copies of drawings, specifications, test reports, and Federal acceptance letters to the Director of the Materials Bureau. The review process requires a minimum of 30 calendar days. Upon approval, the name of the manufacturer and the product will be placed on the Approved List.

## TEMPORARY TRAFFIC CONTROL DEVICES

**BASIS OF ACCEPTANCE.** Test Level 2 or Test Level 3 temporary impact attenuators will be accepted on the basis of the product appearing on the Approved List and a material certification that the product is the same as the one appearing on the Approved List and that it conforms to this specification.

**729-11 TEMPORARY IMPACT ATTENUATORS - GATING**

**SCOPE.** This specification covers the material and performance requirements for temporary impact attenuators. Temporary impact attenuators are defined by FHWA as a Category III device.

**MATERIALS REQUIREMENTS.** Temporary impact attenuators shall be NCHRP 350 or MASH approved as a gating device. Temporary impact attenuators that use liquid or other materials as a filler or to provide ballast will be evaluated for potential environmental impacts and/or seasonal limitations. Temporary impact attenuators meeting the requirements of NCHRP 350 or MASH Test Level 2 are acceptable only as Test Level 2 devices. A Temporary impact attenuator accepted as a Test Level 3 device is also acceptable as Test Level 2 device. Temporary impact attenuators will be approved for use in shielding an object of a maximum width as specified in the Approved List, and specific configurations may be approved for maximum speeds. Approach ends of Temporary impact attenuators shall have impact attenuator markings in accordance with the MUTCD.

Concrete Grouting Material	701-05
Anchoring Materials - Chemically Curing	701-07

If a temporary foundation slab is required, concrete shall be Class A concrete conforming to Section 501 *Portland Cement Concrete - General*; reinforcing steel shall conform to §709-01 *Bar Reinforcement, Grade 420*.

**BASIS OF APPROVAL.** Manufacturers or material suppliers desiring to have Test Level 2 or Test Level 3 temporary impact attenuators approved shall prepare and submit copies of drawings, specifications, test reports, and Federal acceptance letters to the Director of the Materials Bureau. The review process requires a minimum of 30 calendar days. Upon approval, the name of the manufacturer and the product will be placed on the Approved List.

**BASIS OF ACCEPTANCE.** Test Level 2 or Test Level 3 temporary impact attenuators will be accepted on the basis of the product appearing on the Approved List and a material certification that the product is the same as the one appearing on the Approved List and that it conforms to this specification.

**729-12 TRUCK-MOUNTED AND TRAILER MOUNTED IMPACT ATTENUATORS**

**SCOPE.** This specification covers the material and performance requirements for truck mounted impact attenuators or trailer mounted impact attenuators (TMIA's) mounted on the rear of work vehicles and barrier trailers. Impact attenuators are defined by FHWA as a Category III device.

**MATERIALS REQUIREMENTS.** TMIA's shall be NCHRP 350 or MASH approved. TMIA's meeting the requirements of NCHRP 350 or MASH Test Level 3 are also acceptable as a Test Level 2 device. TMIA's meeting the requirements of NCHRP 350 or MASH Test Level 2 are acceptable only as Test Level 2 devices. Approach ends of TMIA's shall have impact attenuator markings in accordance with the MUTCD.

**BASIS OF APPROVAL.** Manufacturers or material suppliers desiring to have products considered for inclusion on the Approved List shall prepare and submit copies of drawings, specifications, test reports, and Federal Acceptance Letters to the Director of the Materials Bureau. The review process requires a minimum of 30 calendar days. Upon approval, the name of the manufacturer and the product will be placed on the Approved List.

**BASIS OF ACCEPTANCE.** Test Level 2 or Test Level 3 TMIA's will be accepted on the basis of the product appearing on the Approved List and a material certification that the product is the same as the one appearing on the Approved List and that it conforms to this specification.

### 729-13 TEMPORARY SAND BARRELS

**SCOPE.** This specification covers the material and performance requirements for sand barrels. Sand barrels are defined by FHWA as a Category III device.

**MATERIAL REQUIREMENTS.** Sand barrels of each size module shall be NCHRP 350 or MASH approved. Sand barrels shall be yellow, durable, waterproof, ultraviolet-stable plastic. The first barrel in the array shall have impact attenuator markings in accordance with the MUTCD.

Sand barrels shall resist deformation from dynamic loadings due to vibration in the placement area and long-term stresses induced by thermal expansion/contraction and fill settlement. Sand barrels shall be free draining with respect to residual moisture in the fill sand. Lids shall divert precipitation and prevent moisture from entering the module. Lids shall be fastened or otherwise secured to provide a closed, reasonably vandal-resistant barrel.

The fill sand shall conform to the requirements of either ' 703-06 *Cushion Sand* or ' 703-07 *Concrete Sand*. Sodium chloride, as dry rock salt, equal to 3-5 % by weight of the sand, shall be thoroughly mixed into the sand. Sodium chloride shall meet the requirements of ' 712-03 *Sodium Chloride*.

**BASIS OF APPROVAL.** Manufacturers or material suppliers desiring to have products considered for inclusion on the Approved List shall prepare and submit copies of drawings, specifications, test reports, and Federal Acceptance Letters to the Director of the Materials Bureau. The review process requires a minimum of 30 calendar days. Upon approval, the name of the manufacturer and the product will be placed on the Approved List.

**BASIS OF ACCEPTANCE.** Sand barrels will be accepted on the basis of the product appearing on the Approved List and a material certification that the product is the same as the one appearing on the Approved List and that it conforms to this specification.

### 729-14 VEHICLE-ARRESTING SYSTEMS

**SCOPE.** This specification covers the material and performance requirements for vehicle-arresting systems. Vehicle-arresting systems are defined by FHWA as a Category III device.

**MATERIAL REQUIREMENTS.** Vehicle-arresting systems shall be NCHRP 350 or MASH approved.

**BASIS OF APPROVAL.** Manufacturers or material suppliers desiring to have products considered for inclusion on the Approved List shall prepare and submit copies of drawings, specifications, test reports, and Federal Acceptance Letters to the Director of the Materials Bureau. The review process requires a minimum of 30 calendar days.

**BASIS OF ACCEPTANCE.** Vehicle-arresting systems will be accepted on the basis of the product appearing on the Approved List and a material certification that the product is the same as the one appearing on the Approved List and that it conforms to this specification.

### 729-15 ARROW PANELS

**SCOPE.** This specification covers the material and performance requirements for arrow panels. Arrow panels are defined by FHWA as a Category IV device.

**MATERIAL REQUIREMENTS.** Arrow panels shall be signs with a matrix of illuminated elements capable of either flashing or sequential arrow displays that meets the requirements of the MUTCD. Arrow panels shall be equipped with a sign control console, mounted in a lockable, weather-resistant compartment.

Arrow panels shall not bear any advertising message or any other message that is not related to traffic control. A nonretroreflective logo or name and telephone number of the contractor or supplier may be located on the back of the arrow panel or on the arrow panel trailer. The logo shall not exceed 0.1 m<sup>2</sup>. The name and telephone number shall not exceed inches in height. The rear face of the arrow panel shall contain one or more clear lamp(s) to indicate that the arrow board is operating properly.



**Truck-Mounted Series B.** Arrow panels consist of a 60 x 30 inch rectangular panel mounted at a minimum of 5 feet above the roadway. The arrow display shall be legible at a minimum distance of 3/4 mile on a bright, sunny day or a clear night when the sight line is unobstructed.

**Trailer-Mounted or Truck-Mounted Series C.** Arrow panels consist of a 96 x 48 inch rectangular panel mounted at a minimum of 7 feet above the roadway for trailer mounted arrow panels and 5 feet above the roadway for truck mounted arrow panels. Arrow panels shall be powered by self-contained engine-driven generator systems, capable of energizing the arrow displays for 72 hours unattended and shall be capable of being powered by 110V AC supply; solar-powered, capable of energizing the arrow displays continuously for 21 days unattended; or powered by a truck. Arrow panel operation controls shall be mounted in a lockable enclosure. The arrow display shall be legible at a minimum distance of 1 mile on a bright, sunny day or a clear night when the sight line is unobstructed.

**TESTING.** Manufacturers or material suppliers desiring to have Truck-Mounted Series B arrow panels considered for inclusion on the Approved List shall submit a material certification that the arrow panel conforms to this specification and the requirements of the MUTCD, and provide an arrow panel to the Director, Materials Bureau in Albany for initial field testing. Field testing will include evaluation of arrow panel operation during various light conditions for brightness, legibility, and angularity. The review process requires a minimum of 30 calendar days.

Manufacturers or material suppliers desiring to have Trailer-Mounted or Truck-Mounted Series C arrow panels considered for inclusion on the Approved List shall submit test results from the AASHTO National Transportation Product Evaluation Program (NTPEP), a material certification that the arrow panel conforms to this specification and the requirements of the MUTCD, and provide an arrow panel to the Director of the Materials Bureau in Albany for initial field testing. Field testing will include evaluation of arrow panel operation during various light conditions for brightness, legibility, and angularity. The review process requires a minimum of 30 calendar days.

**BASIS OF APPROVAL.** Truck-Mounted Series B arrow panels meeting the requirements of this specification and having satisfactory initial field test results will be placed on the Approved List.

Trailer-Mounted or Truck-Mounted Series C arrow panels meeting the requirements of this specification and satisfactory initial field test results, as well as satisfactory NTPEP test results will be placed on the Approved List. Trailer-Mounted or Truck-Mounted Series C arrow panels for which NTPEP test results have not been submitted may be provisionally placed on the Approved List for a maximum of one year. After one year of provisional approval, the manufacturer may request an extension for one additional year based on a pending application filed with NTPEP for testing. No extensions of provisional approvals past two years will be granted. If satisfactory test results are not provided by the expiration date of the provisional approval, all units provided or in use shall be removed and replaced by the Contractor with approved units at no additional cost to the State. Arrow panels on the Approved List that have repeated poor evaluations will be removed from the Approved List.

**BASIS OF ACCEPTANCE.** Arrow panels will be accepted on the basis of the product appearing on the Approved List and a material certification that the product meets this specification and is the same as the one appearing on the Approved List.

## **729-16 PORTABLE VARIABLE-MESSAGE SIGNS (PVMS)**

**SCOPE.** This specification covers the material and performance requirements for variable-message signs. Variable-message signs are defined by FHWA as a Category IV device.

**MATERIAL REQUIREMENTS.** Portable variable-message signs (PVMS) shall be tested by the National Transportation Product Evaluation Program (NTPEP) of the American Association of State and Highway Transportation Officials (AASHTO) demonstrating the arrow panel meets the requirements of this specification and the MUTCD. PVMS shall be trailer mounted and equipped for use on public highways in accordance with NYS Vehicle and Traffic Law. The unit shall operate primarily from a solar-powered electrical system and shall be capable of energizing the message display for a minimum of 21 days without auxiliary charge. The electrical system shall

## D262100

### TEMPORARY TRAFFIC CONTROL DEVICES

consist of batteries and a solar array panel and on-board auxiliary charging system to enable the batteries to be recharged via a 110V AC connection.

PVMS shall have a 3 line display with a minimum of 8 characters per line, and shall be capable of displaying 3 separate messages in a cyclical sequence. Characters shall be a minimum of 18 inches high.

PVMS shall be visible at a minimum distance of 1/2 mile during the day and at night. For highways with a posted pre-construction speed limit of 55 mph or greater, PVMS messages shall be legible from a minimum distance of 800 feet during the day, and 600 feet at night. For highways with a posted pre-construction speed limit of 50 mph or less, PVMS messages shall be legible from a minimum distance of 650 feet during the day. PVMS shall not bear any advertising message or any other message that is not related to traffic control. A nonretroreflective logo or name and telephone number of the contractor or supplier may be located on the back of the PVMS or on the PVMS trailer. The logo shall not exceed 1 square foot. The name and telephone number shall not exceed 2 inches in height.

PVMS shall be equipped with a sign control console, mounted in a lockable, weather-resistant compartment. The sign controller shall have programmable memory capable of storing messages pertinent to planned construction activities, including emergency messages. The controller shall be equipped with 14 day calendar programming capability, providing the ability to start and stop the display of a minimum of three (3) different messages on a repeating schedule without an operator present. The controller shall be capable of producing an accurate log of all messages and the times they were displayed. The controller shall have programmable messages, display rate, and display interval settings. The controller shall blank the sign if the output voltage drops below the manufacturer's recommended output level.

PVMS shall be equipped with control software using a Microsoft Windows operating system. The Contractor shall supply the Engineer with two copies of operating instructions for the PVMS and the control software. Electronic copies of software instructions are acceptable.

**A. Light-Emitting Diode (LED) Type.** LED type PVMS shall have light-emitting diodes arranged in arrays and the arrays shall be arranged in a matrix for each character to be 7 pixels high by 5 pixels wide. The LED display shall have the ability to display characters at a minimum height of 18 inches. The controller shall provide a means of dimming the pixels.

**B. Hybrid Flip-Disk Type.** Hybrid, flip-disk type PVMS shall have pixels consisting of individual electromagnetic disks with at least two (2) high-output amber LEDs. The disk face shall be covered with yellow prismatic retroreflective sheeting or an approved equal. The PVMS shall operate using both flip-disk and light-emitting diode (LED) during nighttime and low-light periods. The hybrid flip disk type shall be arranged in a matrix of 7 disks high by 5 disks wide for each character.

**C. Cellular Communications Option.** PVMS with cellular communications shall be equipped with a cellular telephone with cellular service and a modem capable of remotely operating the control software. The phone numbers for PVMS on a contract shall be sequential whenever possible to facilitate remote control of multiple devices. The unit shall accept a land line telephone connection mode without rewiring or modification.

**D. Radar Option.** The PVMS with radar shall be equipped with a radar speed detection option, providing the system with the ability to determine the speed of an approaching vehicle and interrupt the programmed sequence with a special default message displaying the vehicle's speed. The unit shall collect and store vehicle speed data for retrieval.

**E. NTCIP Communication Protocol Option.** PVMS units that will be operated by the Department, typically from a Transportation Management Center (TMC), shall be equipped with communications and control systems that are National Transportation Communications for ITS Protocol (NTCIP) compliant.

**TESTING.** Manufacturers or material suppliers desiring to have PVMS considered for inclusion on the Approved List shall submit test results from the AASHTO National Transportation Product Evaluation Program (NTPEP), a material certification that the PVMS conforms to this specification and the requirements of the MUTCD, and provide a PVMS to the Director, Materials Bureau in Albany for initial field testing. Field testing will include evaluation of PVMS

operation during various light conditions for brightness, legibility, and angularity. The initial testing process requires a minimum of 30 calendar days.

**BASIS OF APPROVAL.** PVMS meeting the specification, having satisfactory NTPEP test results, and having satisfactory initial field test results will be placed on the Approved List.

PVMS meeting the specification, and having satisfactory initial field test results, that do not have NTPEP test results may be provisionally placed on the Approved List for a maximum of one year. After one year of provisional approval, the manufacturer may request an extension for one additional year based on a pending application filed with NTPEP for testing. No extensions of provisional approvals past two years will be granted. No extensions of provisional approvals will be granted. If satisfactory test results are not provided by the expiration date of the provisional approval, all units provided or in use shall be removed and replaced by the Contractor with approved units at no additional cost to the State. PVMS on the Approved List that have repeated poor evaluations will be removed from the Approved List.

**BASIS OF ACCEPTANCE.** PVMS will be accepted on the basis of the product appearing on the Approved List and a material certification that the product meets this specification and is the same as the one appearing on the Approved List.

### **729-17 TEMPORARY GLARE SCREENS**

**SCOPE.** This specification covers the material and performance requirements for temporary glare screens. Glare screens are not defined separately by FHWA, but rather are considered a system component.

**MATERIAL REQUIREMENTS.** Temporary glare screens shall consist of a opaque screen on a horizontal base which is, in turn, mounted on a concrete barrier. The system shall be modular to allow flexible use and ease of maintenance.

The screen shall be constructed of durable, lightweight, flexible, weather-resistant and impact-resistant materials of a single, uniform dark color. The minimum height of the screen shall be approximately 24 inches. The screen shall be reflectorized at a uniform maximum spacing of 40 feet. If barrier delineation is blocked, the screen shall be reflectorized on both sides with a 3 inch wide by 6 inch high (minimum) piece of reflective sheeting, ASTM Type I (Class A), ASTM Type III (Class B), or higher. Yellow reflective sheeting shall be used facing traffic which is to pass to the right of the glare screen. White reflective sheeting shall be used facing traffic which is to pass to the left of the glare screen.

Individual temporary glare screen modules shall not span a joint between concrete barrier sections, and bases shall not overhang the face of the barrier. Temporary glare screens shall not have any horizontal rigid members that could potentially spear an impacting vehicle, or shall be NCHRP 350 or MASH approved if the system has horizontal rigid members.

The base shall have sufficient rigidity to facilitate ease of handling and proper screen support and position. The connection of the base to the vertical components shall prevent unintentional screen rotation or dislocation. The base shall be properly secured to prevent it from being dislodged upon impact.

**BASIS OF ACCEPTANCE.** Upon request, the Contractor shall provide a material certification that the product conforms to this specification.

### **729-18 WARNING LIGHTS**

**SCOPE.** This specification covers the material and performance requirements for warning lights. Warning lights are not defined separately by FHWA, but rather are considered a system component.

**MATERIAL REQUIREMENTS.** Warning lights shall be mounted on signs or channelizing devices in a manner that, if hit by an errant vehicle, they will not be likely to penetrate the windshield. Warning lights shall be Type A (low-intensity flashing), Type B (high-intensity flashing), or Type C (steady-burning). Warning lights shall meet the requirements of the MUTCD Section 6F.83 and the ITE *Purchase Specification for Flashing and Steady Burn Warning Lights*. Warning lights shall have a minimum nominal diameter of 7 inches and shall emit yellow light.

## D262100

### TEMPORARY TRAFFIC CONTROL DEVICES

Flashing warning lights shall flash between 55 and 75 times per minute. Flashing warning lights required to operate 24 hours per day shall be Type B. Steady-burning warning lights shall operate from one-half hour after sunset to one-half hour before sunrise. Warning lights shall have a minimum mounting height of 30 inches to the bottom of the lens. Warning lights shall be powered by batteries, line power, or solar cells adequate to maintain the required luminance during all periods of required operation.

**BASIS OF ACCEPTANCE.** Upon request, the Contractor shall provide a material certification that the product conforms to this specification.

#### 729-19 AUTOMATED FLAGGER ASSISTANCE DEVICES

**SCOPE.** This specification covers the material and performance requirements for automated flagger assistance devices (AFAD) designed to control road users through work zones to be remotely operated by a flagger. AFADs are defined by FHWA as a Category IV device.

**MATERIAL REQUIREMENTS.** AFADs shall meet the requirements of the MUTCD. Each AFAD shall consist of a remotely controlled self-contained trailer or movable cart consisting of *STOP/SLOW* signs or *RED/YELLOW* lenses.

Stop/Slow Sign AFAD shall consist of:

- A *STOP/SLOW* sign (R1-1/W20-8) having an octagonal shape of at least 36 x 36 inch with letters at least 12 inches high.
  - One red stop beacon, 12 inch diameter red Light Emitting Diode (LED), mounted above the *STOP* sign.
  - At least one amber beacon, 12 inch diameter amber Light Emitting Diode (LED) or Type B high-intensity flashing warning light mounted above, below or to the side(s) of the *SLOW* sign.
- A gate arm capable of extending up to 8.5 feet.
- *WAIT ON STOP* (R1-7) and *GO ON SLOW* (R1-8) signs mounted under the *STOP/SLOW* sign.
  - *WAIT ON STOP* sign shall be a 24 x 30 inches with black legend and black border on a white background with letters at least 2 inches high.
  - *GO ON SLOW* sign shall be a 24 x 30 inches with black legend and black border on a white background with letters at least 2 inches high.
- All sign sheeting shall conform to §730-05 *Reflective Sheeting* ASTM Type IX (Class E).

RED/Yellow Lens AFAD shall consist of:

- Circular red and circular yellow 12 inch diameter Light Emitting Diode (LED) displays.
- A gate arm capable to extend up to 8.5 feet.
- *STOP HERE ON RED* sign (R10-6) 24 x 30 inches.
- All sign sheeting shall conform to §730-05 *Reflective Sheeting* ASTM Type IX (Class E).

The AFADs shall be controlled by a single flagger with a remote control, which shall allow safe operation of two AFADs remotely, employ bi-directional communications to verify each command sent from the handheld was successfully received, be equipped with conflict monitoring to prevent displaying a *SLOW* message simultaneously in both directions, permit an override feature to allow a simultaneous slow display, and show the current status of each AFAD. The control console and power supply shall be housed in a locked compartment. Each trailer/cart shall be equipped with a remote control warning horn alerting workers of intruding vehicles.

Trailers/carts shall display a minimum of 2 inch wide band of reflective sheeting on all four sides of the trailer. Reflective sheeting shall conform to §730-05 *Reflective Sheeting* ASTM Type III (Class B), ASTM Type VII (Class C) or ASTM Type IX (Class E). The sheeting need not be continuous, but the sum of the length of the segments shall be at least one-half the length of the trailer. AFADs shall not bear an advertising message(s) or any other message that is not related to traffic control. A nonretroreflective logo or name and telephone number of the contractor or supplier not to exceed 1.0 square feet may be located on the trailer or cart. The name and telephone number shall not exceed 2 inches in height.

## TEMPORARY TRAFFIC CONTROL DEVICES

**BASIS OF APPROVAL.** Manufacturers or material suppliers desiring to have AFADs be considered for inclusion on the Approved List shall submit a material certification that the AFADs meet this specification and the requirements of the MUTCD, as well as provide one AFAD for initial field testing to the Director of the Materials Bureau in Albany for review. Initial field testing will include evaluating the AFADs for operation, sign visibility/legibility, retractable arm functionality/visibility and beacon/warning light brightness and angularity. The review process requires a minimum of 30 calendar days.

AFADs having acceptable certifications and satisfactory initial field test results will be placed on the Approved List. AFADs that consistently have repeated poor evaluations will be removed from the approved list.

**BASIS OF ACCEPTANCE.** AFADs will be accepted on the basis of the product appearing on the Approved List and a material certification that the product is the same as the one appearing on the Approved List and that it conforms to this specification.

**729-20 PORTABLE TRAFFIC SIGNALS**

**SCOPE.** This specification covers the material and performance requirements for portable traffic signals. Portable traffic signals are defined by FHWA as a Category IV device.

**MATERIAL REQUIREMENTS.** Portable traffic signals shall meet the requirements of the MUTCD. Portable traffic signals shall consist of two self-contained, trailer-mounted traffic signals, each with a vertical signal mast, horizontal mast arm and two - 3 section traffic signal heads. Each traffic signal head shall have 12 inch diameter circular red, yellow and green Light Emitting Diode (LED) modules.

The portable traffic signal system shall be able to function continuously and independent of utility power sources. The signal control console and power supply shall be housed in a locked compartment. The traffic signal controller shall be password protected, capable of providing traffic-actuated control with microwave detector sensors, have a built-in conflict monitor to prevent the display of conflicting indications, shall be hard-wired or radio-controlled to keep the signal indications synchronized, and have adequate phasing to serve expected traffic movements.

Trailers shall display a minimum of 2 inch wide band of reflective sheeting on all four sides of the trailer. Reflective sheeting shall conform to §730-05 *Reflective Sheeting* ASTM Type III (Class B), ASTM Type VII (Class D) or ASTM Type IX (Class E). The sheeting need not be continuous, but the sum of the length of the segments shall be at least one-half the length of the trailer. Portable traffic signals shall not bear an advertising message(s) or any other message that is not related to traffic control. A nonretroreflective logo or name and telephone number of the contractor or supplier may be located on the portable traffic signal trailer. The logo shall not exceed 1.0 square feet. The name and telephone number shall not exceed 2 inches in height.

**BASIS OF APPROVAL.** Manufacturers or material suppliers desiring to have Portable Traffic Signals considered for inclusion on the Approved List shall submit a material certification that the Portable Traffic Signal meets this specification and the requirements of the MUTCD, as well as one portable traffic signal for initial field testing to the Director of the Materials Bureau in Albany for review. Initial field testing will include evaluating the traffic signal system for phasing, clearances, detector operation and layout of the signal faces for brightness and angularity. The review process requires a minimum of 30 calendar days. Portable traffic signals having acceptable certifications and satisfactory initial field test results will be placed on the Approved List.

Portable traffic signals on the Approved List that consistently have poor evaluations will be removed from the Approved List.

**BASIS OF ACCEPTANCE.** Portable traffic signals will be accepted on the basis of the product appearing on the Approved List and a material certification that the product is the same as the one appearing on the Approved List and that it conforms to this specification.

**729-21 TEMPORARY OVERLAY MARKERS**

**SCOPE.** This specification covers the material and performance requirements for temporary overlay markers.

**D262100**  
**TEMPORARY TRAFFIC CONTROL DEVICES**

**MATERIAL REQUIREMENTS.** Temporary overlay markers are flexible polymer “L” shaped road reflectors with an adhesive on its base to adhere to the pavement surface. Temporary overlay markers are approximately 4 inches wide by 2 inches high with at least a 1 inch base. Yellow temporary overlay markers have a yellow reflective sheeting strip a minimum of 1/4 inch in height at the top of the vertical section on both sides. White temporary overlay markers have a white reflective strip a minimum of 1/4 inch in height at the top of the vertical section on one side only. Reflective sheeting shall conform to §730-05 *Reflective Sheeting* ASTM Type III (Class B), ASTM Type VII (Class D) or ASTM Type IX (Class E).

**BASIS OF ACCEPTANCE.** Upon request, the Contractor shall provide a material certification that the product conforms to this specification.

**729-21 TEMPORARY OVERLAY MARKERS  
730-21 FLEXIBLE DELINEATOR POSTS**

Make the following modification to EI 11-018:

**Page 13**

**729-21 TEMPORARY OVERLAY MARKERS**

Delete the **MATERIAL REQUIREMENTS** Section in its entirety and **replace** it with the following:

**“MATERIAL REQUIREMENTS.** Temporary overlay markers are flexible polymer “L” shaped road reflectors with an adhesive on its base to adhere to the pavement surface. Temporary overlay markers are approximately 4 inches wide by 2 inches high with at least a 1 inch base. Yellow temporary overlay markers have a yellow reflective sheeting strip a minimum of ¼ inch in height at the top of the vertical section on both sides. White temporary overlay markers have a white reflective strip a minimum of ¼ inch in height at the top of the vertical section on one side only. Reflective sheeting shall conform to §730-05 *Reflective Sheeting* ASTM Type III (Class B), ASTM Type V (Class C), ASTM Type VII (Class D) or ASTM Type IX (Class E).”

Make the following change to the Standard Specifications of May 1, 2008:

**Page 1037** under **730-21 FLEXIBLE DELINEATOR POSTS**, delete the **MATERIAL REQUIREMENTS** Section in its entirety and **replace** it with the following:

**“MATERIALS REQUIREMENTS.** Flexible delineator posts shall be supplied with reflective sheeting of a size and color as required by the contract documents. The color of the posts shall match the color of the reflective sheeting unless otherwise specified in the contract documents. Where double unit reflectors are specified, elongated reflective sheeting may be substituted as in accordance with the MUTCD.

Reflective sheeting shall be fabricated of a material conforming to the requirements of §730-05 Reflective Sheeting, Class B, Class C, or Class E. Sheeting shall be applied in accordance with the sheeting manufacturer’s written instructions.”

**REFLECTORIZED SHEETING SIGN CHARACTERS**

Make the following changes to the Standard Specifications of May 1, 2008:

**Page 1036:**

*Delete* entirely Standard Spec 730-12 and *replace* with:

**“730-12 REFLECTORIZED SHEETING SIGN CHARACTERS (TYPE IV)**

**SCOPE.** These specifications cover the material requirements for Type IV reflectorized sheeting sign characters.

**MATERIAL REQUIREMENTS.** Type IV characters shall consist of cutout reflective sheeting material meeting the requirements of §730-05 Reflective Sheeting, Materials Designation 730-05.02 (Class B).

Characters or borders shall be applied directly to clean, dust-free reflective sheeting background panels. Characters or borders shall be applied mechanically with equipment and in a manner specified by the sheeting manufacturer. Borders shall be cut neatly and butt-joined at corners and panel joints.

**TESTING.** The Department reserves the right to conduct tests on samples taken by a representative of the Department as follows: 2% or a minimum of five (5) characters (whichever is the greater) for each size character used; and 2% or a minimum of 2 ft of border (whichever is greater) for each width of border used.

When performed, tests will be conducted in accordance with §730-05 Reflective Sheeting.

**BASIS OF ACCEPTANCE.** Type IV characters will be accepted on the basis of a material certification that the product conforms to this specification.”

**Page 1036:**

*Delete* entirely Standard Spec 730-13 and *replace* with:

**“730-13 REFLECTORIZED SHEETING SIGN CHARACTERS (TYPE V)**

**SCOPE.** These specifications cover the material requirements for Type V reflectorized sheeting sign characters.

**MATERIAL REQUIREMENTS.** Type V characters shall consist of a painted, screened, or reverse-screened application of paint, paste, or transparent color of a type and in a manner recommended by the manufacturer of the reflective material.

Reflective material used for reverse-screened signs shall meet the requirements of §730-05 **Reflective Sheeting**, Materials Designation 730-05.02 (Class B).

**TESTING.** The Department reserves the right to conduct tests on samples taken by a representative of the Department as follows: 2% or a minimum of five (5) characters (whichever is the greater) for each size character used; and 2% or a minimum of 2 ft of border (whichever is greater) for each width of border used.

When performed, tests will be conducted in accordance with §730-05 Reflective Sheeting.

**BASIS OF ACCEPTANCE.** Type V characters will be accepted on the basis of a material certification that the product conforms to this specification.”



**SECTION 733 – EARTHWORK MATERIALS**

Make the following changes to the Standard Specifications dated May 1, 2008:

Page 1049, Delete SECTION 733 AND 734 (VACANT) and Replace it with the following:

**SECTION 733 – EARTHWORK MATERIALS**

**733-01 B FLOWABLE FILL**

**SCOPE.** This specification covers the material requirements and methods of testing flowable fill. The following flowable fill types are evaluated in this specification:

- 733.0101 – Controlled Low Strength Material (CLSM)
- 733.0102 – Controlled Low Strength Material (CLSM) (No Fly Ash)
- 733.0103 – Lightweight Concrete Fill (Type A)
- 733.0104 – Lightweight Concrete Fill (Type B)

**GENERAL.**

**A. Controlled Low Strength Material.** Provide CLSM with certified test results supplied by a qualified independent testing laboratory for the mix design verifying the unconfined compressive strength meets the requirements of the specification. Design the CLSM mix so that it sets within the time stated in the contract documents. If no set time is required, design the set time to meet Contractor’s operational requirements.

**B. Lightweight Concrete Fill.** Provide Lightweight Concrete Fill with certified test results supplied by a qualified independent testing laboratory for the mix design verifying the wet cast density and unconfined compressive strength meet the requirements of the specification for the type(s) identified in the contract documents. Design the Lightweight Concrete Fill utilizing a foaming agent appearing on the Departments Approved List.

**MATERIAL REQUIREMENTS.**

**A. Controlled Low Strength Material.**

**1. Material.** Provide CLSM containing cement and water. At the Contractor’s option, it may also contain fly ash (unless the No Fly Ash item is specified), aggregate, or chemical admixtures in any proportions such that the final product meets the strength and flow consistency requirements included in this specification.

Provide materials meeting the requirements of Table 733-01A *CLSM Material Requirements*:

<b>TABLE 733-01A CLSM MATERIAL REQUIREMENTS</b>	
<b>Material</b>	<b>Subsection</b>
Portland Cement, Type 1 or Type 2	§701-01
Water	§712-01

If used, provide materials meeting Table 733-01B *Requirements for Optional CLSM Material*:

## SECTION 733 – EARTHWORK MATERIALS

TABLE 733-01B REQUIREMENTS FOR OPTIONAL CLSM MATERIAL	
Material	Subsection
Aggregate Gradation	§703-07 <i>Concrete Sand</i>
Fly Ash	Provide fly ash that complies with the requirements of §711-10 <i>Fly Ash</i> except that the loss on ignition requirement is waived.
Chemical Admixtures	Provide admixtures that comply with §711-08 <i>Admixtures</i> . The mix may include high air generators manufactured for CLSM.

**2. Unconfined Compressive Strength.** Provide CLSM with a mix design generating an unconfined compressive strength in Table 733-01C *CLSM Unconfined Compressive Strength*:

TABLE 733-01C CLSM UNCONFINED COMPRESSIVE STRENGTH	
Test Age	Unconfined Compressive Strength
28 days	$40 \text{ psi} \leq q_u \leq 150 \text{ psi}$

### 3. Sampling and Testing.

**i. Spread Diameter.** Provide CLSM that has, at the time of placement, a minimum diameter spread of 8 in. as determined by a Department Representative in accordance with ASTM D6103 *Standard Test Method for Flow Consistency of Controlled Low Strength Material (CLSM)*.

**ii. Cylinder Cast.** A Department Representative will cast three specimens (cylinders) for each batch of CLSM for QA testing. A batch is defined as the amount of material that can be mixed at one time.

### B. Lightweight Concrete Fill.

**1. Material.** Provide materials meeting the requirements of Table 733-01D *Lightweight Concrete Fill Material Requirements*:

TABLE 733-01D LIGHTWEIGHT CONCRETE FILL MATERIAL REQUIREMENTS	
Material	Subsection
Portland Cement, Type 1, 2 of 3	§701-01
Water	§712-01
Admixtures	§711-08
Foaming Agent	See Below

The Foaming Agent shall conform to the requirements of ASTM C 869. Foaming Agents which are on the Approved List shall be accepted at the site on the basis of the brand name labeled on the Foaming Agent container and certified documentation provided by the supplier.

A Foaming Agent not on the Approved List will be evaluated based on submitted information and sample testing by the Materials Bureau (minimum of six months). For each class of material

**SECTION 733 – EARTHWORK MATERIALS**

submitted for evaluation, specimens will be required for testing of compressive strength, air-dry density, freeze-thaw and water absorption characteristics, and other testing as deemed appropriate. For detailed information contact the Materials Bureau.

**2. Concrete Fill Types.** Provide lightweight concrete fill conforming to the type(s) specified in the contract documents and meeting the requirements identified in Table 733-01E *Lightweight Concrete Fill Density and Compressive Strength Requirements*.

<b>TABLE 733-01E LIGHTWEIGHT CONCRETE FILL DENSITY AND UNCONFINED COMPRESSIVE STRENGTH REQUIREMENTS</b>		
<b>Type</b>	<b>Maximum Cast Wet Density (pcf)</b>	<b>Minimum Unconfined Compressive Strength – 28 days (psi)</b>
A	30	40
B	42	100

The Contractor shall be responsible for designing the mix so that each type of lightweight concrete fill meets the corresponding criteria listed above. The lightweight concrete fill shall be mixed in accordance with the recommendations of a representative of the supplier of the foaming agent.

**3. Sampling and Testing.**

**i. Density.** A Department Representative will sample and test the wet cast density. After the initial test and approval to proceed, the density will be monitored at 30 minute intervals during placement for QA purposes.

**ii. Cylinder Cast.** A Department Representative will cast four specimens (cylinders) at the point of placement for each day's pour or each 100 yd<sup>3</sup> of material placed, whichever is more frequent, for QA purposes.

**BASIS OF APPROVAL.**

**A. Controlled Low Strength Material.** Mix designs will be approved based on certified test results supplied by a qualified independent testing laboratory for the unconfined compressive strength in accordance with the specification. The methods of installation will be approved based on an evaluation of the equipment's appropriateness with respect to the site conditions.

**B. Lightweight Concrete Fill.** Mix designs will be approved based on (1) certified test results supplied by a qualified independent testing laboratory for the maximum wet cast density and minimum unconfined compressive strength in accordance with the specification, and (2) the brand name labeled on the foaming agent appearing on the Approved List. The methods of installation will be approved based on an evaluation of the equipment's appropriateness with respect to the site conditions.

**BASIS OF ACCEPTANCE.**

## SECTION 733 – EARTHWORK MATERIALS

**A. Controlled Low Strength Material.** CLSM material will be accepted on the jobsite upon submission of certified test results of the mix design to the Engineer.

CLSM material will be accepted after employment of the approved method of installation and upon acceptable test results for spread diameter and unconfined compressive strength.

**B. Lightweight Concrete Fill.** Lightweight Concrete Fill material will be accepted on the jobsite upon submission of a certified mix design to the Engineer and confirmation that the brand name labeled on the foaming agent appears on the Approved List.

Lightweight Concrete Fill material will be accepted after employment of the approved method of installation and upon acceptable test results for density and unconfined compressive strength.

### 733-02 B MECHANICALLY STABILIZED EARTH SYSTEM BACKFILL MATERIAL

**SCOPE.** This specification covers the material requirements and methods of testing backfill material generally used for the construction of a MSES.

**SAMPLING.** Perform material tests and assurance methods pertaining to the backfill requirements in conformance with the procedures contained in the geotechnical control procedure “*Procedure for the Control and Quality Assurance of Granular Materials*”.

**GENERAL.** Provide backfill material for any MSES from a single source unless prior approval for use of designated multiple sources is obtained from the Director, GEB.

#### MATERIAL REQUIREMENTS.

**A. STOCKPILE.** Stockpile the backfill material in accordance with the geotechnical control procedure “*Procedure for the Control and Quality Assurance of Granular Materials*”.

**B. GRADATION.** Provide backfill material of one of the following types:

**1. Type A.** Material consisting of any mineral (inorganic) soil, blasted or broken rock, or similar materials of natural origin, including mixtures thereof, and having a gradation in accordance with TABLE 733-02A *Backfill Gradation*.

<b>TABLE 733-02A BACKFILL GRADATION</b>	
<b>Sieve Size Designation</b>	<b>Percentage Passing by Weight</b>
4 in.	100
¼ in.	30-100
No. 40	0-60
No. 200	0-15

**2. Type B.** Material consisting of crushed stone conforming to §703-02 *Coarse Aggregate*, Size Designation 2.

**3. Type C.** Material consisting of recycled Portland Cement Concrete Aggregate (RCA). Type C backfill consists of at least 95%, by weight, of RCA and is free from organic and other deleterious material. Material may contain up to 5% by weight asphalt and/or brick. Gradation for

**SECTION 733 – EARTHWORK MATERIALS**

Type C backfill conforms to Table 733-02A *Backfill Gradation*.

**4. Type D.** Material consisting of recycled Portland Cement Concrete Aggregate (RCA). Type D backfill consists of at least 95%, by weight, of RCA and is free from organic and other deleterious material. Material may contain up to 5% by weight asphalt and/or brick. Gradation for Type D backfill conforms to §703-02 *Coarse Aggregate*, Size Designation 2.

**C. PLASTICITY INDEX.** Provide material having a Plasticity Index not exceeding 5.

**D. DURABILITY.** Provide material having a Magnesium Sulfate Soundness loss less than 30 percent.

**E. CORROSION POTENTIAL (METAL REINFORCING AND/OR CONNECTORS ONLY).** The Department will test for the corrosion potential of any system with exposed metal in the backfill. Stockpiled materials will be tested for resistivity and pH, and may be tested for sulfides at the Department's discretion. Material failing to meet the following requirements of Table 733-02B *Resistivity, Soluble Salts and pH Requirements*, will be rejected except as specified below:

Material failing to meet the resistivity criterion may be tested for sulfate and chlorides. Material meeting the criteria for both sulfates and chlorides and having a resistivity greater than 10 ohm-m will be acceptable. Chemical testing (i.e. resistivity, sulfate ion content, sulfide ion content, and chloride ion content) is not required for Type B backfill or for Type D backfill.

<b>TABLE 733-02B RESISTIVITY, SOLUBLE SALTS AND pH REQUIREMENTS</b>			
<b>Property</b>		<b>Test Method</b>	<b>Acceptance Criteria</b>
Resistivity		AASHTO T288	$\rho \geq 30$ ohm-m
Chlorides		AASHTO T291 Method A	$Cl^- \leq 100$ mg/kg
Sulfates		AASHTO T290 Method A, gravimetric	$SO_4^{2-} \leq 200$ mg/kg
		AASHTO T290 Method B, turbidmetric	
Sulfides		NYSDOT Test Method 711-12C	$S^{2-} \leq 300$ mg/kg
pH	Type A or C	NYSDOT GTM-24	$5 \leq pH \leq 10$
	Type B or D	NYSDOT GTM-24	$5 \leq pH \leq 12.5$

**BASIS OF APPROVAL.** Stockpiles of MSES backfill material will be approved by the GEB in accordance with the geotechnical control procedure “*Procedure for the Control and Quality Assurance of Granular Materials*” and the procedural directives of the GEB.

**BASIS OF ACCEPTANCE.** Backfill material from approved stockpiles will be accepted on the contract site by delivery ticket. Each delivery ticket shall identify the Suppliers name, Suppliers granular source number (GSN), date, NYSDOT contract number, stockpile number, item number and quantity.

Backfill material from approved stockpiles will be accepted as part of the MSES upon confirmation that the material gradation type provided by the Contractor, outlined in §733-02B *Gradation*, conforms to the MSES submittal provided by the wall system designer-supplier and upon successful completion of the

## SECTION 733 – EARTHWORK MATERIALS

Quality Assurance (QA) program indicating that the material conforms to the specification. In addition to the requirements of Section 106 *Control of Material*, the Department will sample and test backfill taken from behind the newly-constructed wall to assure quality. The number of samples and their locations (plan and elevation) will be determined based on the quantity of material to be used in each MSES structure in accordance with the geotechnical control procedure “*Procedure for Taking Random Samples of Backfill Material for Mechanically Stabilized Earth Systems*”. Results from chemical testing (i.e. resistivity, sulfate ion content, sulfide ion content, and chloride ion content) can take several weeks to obtain.

### 733-03 B GEOSYNTHETIC REINFORCED EARTH SYSTEM SLOPE BACKFILL MATERIAL

**SCOPE.** This specification covers the material requirements and methods of testing backfill material generally used for the construction of over steepened slopes utilizing Geosynthetic Reinforced Earth System (GRES).

**SAMPLING.** Obtain a representative sample of the source for the performance of a gradation analysis in accordance with the procedures contained in the geotechnical test method “*Test Method for the Grain-Size Analysis of Granular Soil Materials*”.

**MATERIAL REQUIREMENTS.** Any mineral (inorganic) soil, blasted or broken rock, or similar materials of natural origin, including mixtures thereof, may be suitable materials subject to the following:

**A. GRADATION.** Provide backfill material conforming to the following:

**1. Gradation Spread.** Provide backfill material having a gradation in accordance with TABLE 733-03A *Backfill Gradation*.

TABLE 733-03A BACKFILL GRADATION	
Sieve Size Designation	Percentage Passing by Weight
6 in.	100
No. 40	0-60
No. 200	0-40

**2. Gradation Ratio.** Provide backfill material having a gradation ratio in accordance with the following formula:

$$\frac{\text{Percent Pass. No.200 sieve}}{\text{Percent Pass. No.40 sieve}} \times 100 \leq 70$$

The gradation is evaluated at the contract level.

**BASIS OF APPROVAL.** Sources will be approved upon successful completion of the gradation tests indicating that the material conforms to the specification.

**BASIS OF ACCEPTANCE.** Backfill material will be accepted based upon successful completion of the gradation tests indicating that the material conforms to the specification.

### 733-04 B SUBBASE COURSE

**SCOPE.** This specification covers the material requirements and methods of testing subbase material

**SECTION 733 – EARTHWORK MATERIALS**

generally used in the construction of a pavement structure. The following subbase types are evaluated in this specification:

- 733.0401 – Subbase Course, Type 1
- 733.0402 – Subbase Course, Type 2
- 733.0403 – Subbase Course, Type 3
- 733.0404 – Subbase Course, Type 4

Subbase course types are based on the gradation of the material as outlined in Table 733-04A *Subbase Gradation*.

**SAMPLING.** Perform material tests and assurance methods pertaining to subbase requirements in conformance with the procedures contained in the geotechnical control procedure “*Procedure for the Control and Quality Assurance of Granular Materials*”.

**GENERAL.** Provide suitable material conforming to the requirements of Section 203 *Excavation and Embankment* and to the requirements contained herein.

**MATERIAL REQUIREMENTS.** For Types 1, 3 and 4 furnish materials consisting of approved Blast Furnace Slag, Stone, Sand, and Gravel, or blends of these materials.

For Type 2, furnish materials consisting of approved Blast Furnace Slag or of Stone which is the product of crushing or blasting ledge rock, or a blend of Blast Furnace Slag and of Stone.

**A. STOCKPILE.** Stockpile subbase material in accordance with the geotechnical control procedure “*Procedure for the Control and Quality Assurance of Granular Materials*” except as noted herein.

1. **Type 3.** Material furnished under Type 3 will not be required to be stockpiled unless it contains RCA, glass, or Corian®.
2. **Recycled Materials, Alternate C.** Stockpiling of the Reclaimed Asphalt Pavement (RAP) for Alternate C is not required.

**B. GRADATION.** Provide subbase material having a gradation in accordance with TABLE 733-04A *Subbase Gradation*.

TABLE 733-04A SUBBASE GRADATION				
Sieve Size Designation	Percentage Passing by Weight			
	Type 1	Type 2	Type 3	Type 4
4 in.	-	-	100	-
3 in.	100	-	-	-
2 in.	90-100	100	-	100
¼ in.	30-65	25-60	30-75	30-65
No. 40	5-40	5-40	5-40	5-40
No. 200	0-10	0-10	0-10	0-10

**C. PLASTICITY INDEX.** Provide material having a Plasticity Index based on the material passing the No. 40 mesh sieve equal to or less than 5.0.

**D. DURABILITY.**

### SECTION 733 – EARTHWORK MATERIALS

**1. Types 1, 2 and 4.** Provide material for Types 1, 2 and 4 having a Magnesium Sulfate Soundness loss less than 20% after four (4) cycles, unless material meeting the requirements of *Alternate C* (F. Recycled Materials) is used.

**2. Type 3.** Provide material for Type 3 having a Magnesium Sulfate Soundness loss less than 30% after four (4) cycles.

**E. ELONGATED PARTICLES.** A flat or elongated particle is defined herein as one which has its greatest dimension more than three (3) times its least dimension. Provide material consisting of particles where not more than 30%, by weight, of the particles retained on a ½ in. sieve is flat or elongated. When the State elects to test for this requirement, material with a percentage greater than 30 will be rejected. Acceptance for this requirement will normally be based on a visual inspection by the Regional Geotechnical Engineer.

**F. RECYCLED MATERIALS.** The following materials are an acceptable replacement for Types 1, 3 and 4. Only one alternate shall be selected for use per stockpile.

- **Alternate A.** Recycled Portland Cement Concrete Aggregate (RCA) meeting the requirements of §733-07 Recycled Portland Cement Concrete Aggregate, Alternate A.
- **Alternate B.** Recycled Portland Cement Concrete Aggregate (RCA) meeting the requirements of §733-07 Recycled Portland Cement Concrete Aggregate, Alternate B.
- **Alternate C.** Reclaimed Asphalt Pavement (RAP) meeting the requirements of §733-06 Reclaimed Asphalt Pavement for Earthwork and Subbase.
- **Alternate D.** Blends of Blast Furnace Slag, Stone, Sand, and Gravel, with not more than 30% by weight of glass. Glass shall meet the requirements of §733-05 Glass Backfill.
- **Alternate E.** Blend of Alternate A with not more than 5% by weight of Corian®. Corian® shall meet the requirements of §733-19 Corian® Backfill.
- **Alternate F.** Blend of Alternate B with not more than 5% by weight of Corian®. Corian® shall meet the requirements of §733-19 Corian® Backfill.

**G. MATERIAL FOR TEMPORARY WORK.** Material used as a subbase for the construction of temporary work may be approved by a Departmental Geotechnical Engineer by visual inspection in accordance with the geotechnical control procedure “*Procedure for the Control and Quality Assurance of Granular Materials*”. Do not permanently incorporate material so approved into the work without following the appropriate acceptance procedure.

**BASIS OF APPROVAL.** Stockpiles of subbase material will be approved in accordance with the geotechnical control procedure “*Procedure for the Control and Quality Assurance of Granular Materials*”.

**BASIS OF ACCEPTANCE.** Subbase material from approved stockpiles will be accepted upon successful completion of the Quality Assurance (QA) program indicating that the material conforms to the specification. If the QA program is not introduced, subbase material will be accepted upon the basis of the stockpile approval.

#### 733-05 B GLASS BACKFILL

**SCOPE.** This specification covers the material requirements and methods of assessing glass backfill



## SECTION 733 – EARTHWORK MATERIALS

material generally used as fill material.

**SAMPLING.** Perform material tests and assurance methods pertaining to the glass backfill requirements in conformance with the procedures for stockpiled granular materials contained in the geotechnical control procedure “*Procedure for the Control and Quality Assurance of Granular Materials*”.

### MATERIAL REQUIREMENTS.

**A. STOCKPILE.** Stockpile glass backfill material in accordance with the procedures for stockpiled granular materials contained in the geotechnical control procedure “*Procedure for the Control and Quality Assurance of Granular Materials*”.

**B. GRADATION.** Provide glass crushed to a maximum particle size of 3/8 in. The material shall be subject to visual inspection by the Regional Geotechnical Engineer.

**C. CHARACTERISTICS.** Glass may contain up to a maximum of 5% by volume of china, ceramics, plate glass products, paper, plastics or other deleterious materials.

**BASIS OF APPROVAL.** Glass backfill will be approved in accordance with the procedures for stockpiled granular materials contained in the geotechnical control procedure “*Procedure for the Control and Quality Assurance of Granular Materials*”.

The material shall be subject to visual inspection by the Regional Geotechnical Engineer.

**BASIS OF ACCEPTANCE.** Approved glass backfill material will be accepted upon successful completion of the Quality Assurance (QA) program indicating that the material conforms to the specification. If the QA program is not introduced, glass backfill material will be accepted upon the basis of the stockpile approval.

### 733-06 B RECLAIMED ASPHALT PAVEMENT FOR EARTHWORK AND SUBBASE

**SCOPE.** This specification covers the material requirements and methods of assessing Reclaimed Asphalt Pavement (RAP) generally used as fill material.

**SAMPLING.** Perform material tests and assurance methods pertaining to the RAP requirements in conformance with the procedures contained in the geotechnical control procedure “*Procedure for the Control and Quality Assurance of Granular Materials*”.

### MATERIAL REQUIREMENTS.

**A. SOURCE.** Provide written documentation that the reclaimed bituminous material originated on a Department project. Include an identifier, such as State Highway number, construction contract number or Department Project Identification Number (PIN).

#### B. GRADATION.

**1. Gradation Spread.** Provide RAP having a maximum top size of 2 in. at the time of

## SECTION 733 – EARTHWORK MATERIALS

placement.

**2. Elongated Particles.** A flat or elongated particle is defined herein as one which has its greatest dimension more than three (3) times its least dimension. Provide material consisting of particles where not more than 30%, by weight, of the particles retained on a ½ in. sieve are flat or elongated. When the State elects to test for this requirement, material with a percentage greater than 30 will be rejected. Acceptance for this requirement will normally be based on a visual inspection by the Regional Geotechnical Engineer.

**C. CHARACTERISTICS.** Bituminous material that is well-graded from coarse to fine and free from organic or other deleterious material, including tar. This material is at least 95%, by weight, reclaimed bituminous material. No soundness or Plasticity Index testing will be required.

**BASIS OF APPROVAL.** RAP will be approved based upon a visual inspection by the Regional Geotechnical Engineer.

**BASIS OF ACCEPTANCE.** If this material becomes unstable during construction, it may be necessary to add a mixture of natural suitable material to the RAP. Acceptance of the final product will be based on an evaluation by the Engineer.

Approved RAP will be accepted upon successful completion of the Quality Assurance (QA) program indicating that the material conforms to the specification. If the QA program is not introduced, RAP will be accepted upon the basis of the visual inspection by the Regional Geotechnical Engineer.

### 733-07 B RECYCLED PORTLAND CEMENT CONCRETE AGGREGATE

**SCOPE.** This specification covers the material requirements and methods of testing Recycled Portland Cement Concrete Aggregate (RCA) generally used as fill material. The following RCA types are evaluated in this specification:

733.0701 – Recycled Portland Cement Concrete Aggregate

733.0702 – Recycled Portland Cement Concrete Aggregate Mixture

**SAMPLING.** Perform material tests and assurance methods pertaining to the RCA requirements in conformance with the procedures contained in the geotechnical control procedure “*Procedure for the Control and Quality Assurance of Granular Materials*”.

### MATERIAL REQUIREMENTS.

**A. STOCKPILE.** Stockpile RCA in accordance with the geotechnical control procedure “*Procedure for the Control and Quality Assurance of Granular Materials*”.

If RCA comes from other than a Department project, provide documentation showing that the material obtained is from a NYSDEC registered or permitted construction and demolition (C&D) debris processing facility as specified in Section 360-16.1 of 6NYCRR Part 360, “Solid Waste Management Facilities”.

### B. GRADATION.

## SECTION 733 – EARTHWORK MATERIALS

**1. Gradation Spread.** Provide RCA meeting the gradation requirements for the appropriate item of use.

**2. Elongated Particles.** A flat or elongated particle is defined herein as one which has its greatest dimension more than three (3) times its least dimension. Provide material consisting of particles where not more than 30%, by weight, of the particles retained on a ½ in. sieve are flat or elongated. When the State elects to test for this requirement, material with a percentage greater than 30 will be rejected. Acceptance for this requirement will normally be based on a visual inspection by the Regional Geotechnical Engineer.

### C. CHARACTERISTICS.

**1. Alternate A.** At least 95%, by weight, of Recycled Portland Cement Concrete Aggregate (RCA), and free from organic and other deleterious material. This material may contain up to 5% by weight asphalt and/or brick.

**2. Alternate B.** A mixture of Recycled Portland Cement Concrete Aggregate (RCA) conforming to Alternate A above mixed with stone, sand, gravel or blast furnace slag. This material may contain up to 5% by weight asphalt and/or brick.

**BASIS OF APPROVAL.** Stockpiles of RCA will be approved in accordance with the geotechnical control procedure “*Procedure for the Control and Quality Assurance of Granular Materials*”.

**BASIS OF ACCEPTANCE.** RCA from approved stockpiles will be accepted upon successful completion of the Quality Assurance (QA) program indicating that the material conforms to the specification. If the QA program is not introduced, RCA will be accepted upon the basis of the stockpile approval.

### 733-08 B EMBANKMENT IN PLACE

**SCOPE.** This specification covers the material requirements and methods of assessing material generally used for embankment construction.

**MATERIAL REQUIREMENTS.** In general, any mineral (inorganic) soil, blasted or broken rock and similar materials of natural or man made (i.e. recycled) origin, including mixtures thereof, are considered suitable materials.

**A. GRADATION.** Provide suitable backfill material having no particles with a dimension in excess of two-thirds of the loose lift thickness controlled by the compaction equipment supplied by the Contractor.

Glass incorporated into embankments shall be thoroughly mixed with other suitable material so that Glass constitutes no more than 30% by weight anywhere in the embankment.

The material shall be subject to visual inspection by the Engineer.

**BASIS OF ACCEPTANCE.** Embankment material will be accepted upon visual inspection by the Engineer.

## SECTION 733 – EARTHWORK MATERIALS

**733-09 B SELECT BORROW**

**SCOPE.** This specification covers the material requirements and methods of testing select borrow material generally used for backfilling in areas beneath the watertable.

**SAMPLING.** Perform material tests and quality assurance methods pertaining to the backfill requirements in conformance with the procedures for non-stockpiled materials contained in the geotechnical control procedure “*Procedure for the Control and Quality Assurance of Granular Materials*”.

**MATERIAL REQUIREMENTS.**

**A. SOURCE.** Provide backfill material from a source approved in accordance with the geotechnical control procedure “*Procedure for the Control and Quality Assurance of Granular Materials*”.

**B. GRADATION.** Provide material consisting of rock, stone, slag, cobbles, or gravel, substantially free of shale or other soft, poor durability particles having no particles greater than 3 ft. in maximum dimension. Of the portion passing the 4 in. square sieve, the material shall have a gradation in accordance with TABLE 733-09A *Select Borrow Gradation*.

TABLE 733-09A SELECT BORROW GRADATION	
Sieve Size Designation	Percentage Passing by Weight
No. 40	0-70
No. 200	0-15

The gradation is evaluated at the project level.

**C. DURABILITY.** Provide material having a Magnesium Sulfate Soundness loss less than 35%.

**D. COMPOSITION.** RAP shall not be used.

**BASIS OF APPROVAL.** Sources will be approved in accordance with the geotechnical control procedure “*Procedure for the Control and Quality Assurance of Granular Materials*”.

A preceding source evaluation will be valid for the time identified in the manual. For sources without a current evaluation, samples shall be obtained under the direction of the Departmental Geotechnical Engineer and will be tested and evaluated by the Geotechnical Engineering Bureau.

**BASIS OF ACCEPTANCE.** Approved select borrow backfill material from approved sources will be accepted upon successful completion of the gradation tests and Quality Assurance (QA) program indicating that the material conforms to the specification. If the QA program is not introduced, approved select borrow material will be accepted upon successful completion of the gradation tests.

**733-10 B SELECT FILL**

**SCOPE.** This specification covers the material requirements and methods of testing select fill material

**SECTION 733 – EARTHWORK MATERIALS**

generally used for backfilling in areas beneath the watertable.

**SAMPLING.** The sampling procedure contained in §733-09 *Select Borrow* shall apply.

**MATERIAL REQUIREMENTS.** The material requirements contained in §733-09 *Select Borrow* shall apply.

**BASIS OF APPROVAL.** The basis of approval contained in §733-09 *Select Borrow* shall apply.

**BASIS OF ACCEPTANCE.** The basis of acceptance contained in §733-09 *Select Borrow* shall apply.

**733-11 B SELECT GRANULAR FILL**

**SCOPE.** This specification covers the material requirements and methods of testing select granular fill material generally used for backfilling around pipes. The following materials are evaluated in this specification:

- 733.1101 – Select Granular Fill (Typical)
- 733.1102 – Select Granular Fill for Corrugated Aluminum Pipe

**SAMPLING.** Perform material tests and quality assurance methods pertaining to the backfill requirements in conformance with the procedures for non-stockpiled materials contained in the geotechnical control procedure “*Procedure for the Control and Quality Assurance of Granular Materials*”.

**MATERIAL REQUIREMENTS.**

**A. SOURCE.** Provide backfill material from an approved source in accordance with the geotechnical control procedure “*Procedure for the Control and Quality Assurance of Granular Materials*”.

**B. GRADATION.** Provide material consisting of rock, stone, slag, cobbles, or gravel, substantially free of shale or other soft, poor durability particles and conforming to the following requirements:

1. **Typical.** Except when used as backfill material for aluminum pipe with Type IR corrugations (Spiral Rib Pipe), the material shall have a gradation in accordance with TABLE 733-11A *Select Granular Fill Gradation*.

<b>TABLE 733-11A SELECT GRANULAR FILL GRADATION</b>	
<b>Sieve Size Designation</b>	<b>Percentage Passing by Weight</b>
4 in.	100
No. 40	0-70
No. 200	0-15

2. **Exception.** When used as backfill for Corrugated Aluminum Pipe, Type 1R (Spiral Rib Pipe) 100% of the material shall also pass the 2 in. sieve.

The gradation is evaluated at the project level.

### SECTION 733 – EARTHWORK MATERIALS

**C. DURABILITY.** Provide materials substantially free of shale and soft, poor durability particles. Provide material having a Magnesium Sulfate Soundness loss less than 30%.

**D. COMPOSITION.** RAP shall not be used.

When used as backfill for aluminum pipe, the material shall be free of Portland cement or Portland cement concrete.

**E. pH.** Where the State elects to test for this requirement, the material shall have a pH in accordance with TABLE 733-11B *Select Granular Fill pH Requirement*.

TABLE 733-11B SELECT GRANULAR FILL pH REQUIREMENT		
Property	Test Method	Acceptance Criteria
pH	NYS DOT GTM-24	$5 \leq pH \leq 10$

When RCA is used as backfill in a non-aluminum pipe application, the pH requirements are waived.

**BASIS OF APPROVAL.** Sources will be approved in accordance with the geotechnical control procedure “*Procedure for the Control and Quality Assurance of Granular Materials*”.

A preceding source evaluation will be valid for the time identified in the manual. For sources without a current evaluation, samples shall be obtained under the direction of the Departmental Geotechnical Engineer and will be tested and evaluated by the Geotechnical Engineering Bureau.

**BASIS OF ACCEPTANCE.** Approved select granular fill backfill material from approved sources will be accepted upon successful completion of the gradation tests and Quality Assurance (QA) program indicating that the material conforms to the specification. If the QA program is not introduced, approved select granular fill backfill material will be accepted upon successful completion of the gradation tests.

#### 733-12 B SELECT GRANULAR FILL SLOPE PROTECTION

**SCOPE.** This specification covers the material requirements and methods of testing select granular fill slope protection material generally used for stabilizing sloughing slopes. The following materials are evaluated in this specification:

733.1201 – Select Granular Fill Slope Protection (Blasted Rock)

733.1202 – Select Granular Fill Slope Protection (Typical)

**SAMPLING.** Perform material tests and quality assurance methods pertaining to the backfill requirements in conformance with the procedures for non-stockpiled materials contained in the geotechnical control procedure “*Procedure for the Control and Quality Assurance of Granular Materials*”.

#### MATERIAL REQUIREMENTS.

**A. SOURCE.** Provide backfill material from an approved source in accordance with the geotechnical control procedure “*Procedure for the Control and Quality Assurance of Granular Materials*”.

**SECTION 733 – EARTHWORK MATERIALS**

**B. GRADATION.** Provide material consisting of rock, stone, slag, cobbles, or gravel, substantially free of shale or other soft, poor durability particles.

1. Broken or blasted unweathered rock used for this item shall be well graded, having no particles greater than 24 in. in maximum dimension, and be substantially free from particles greater than 12 in. in maximum dimension, containing little or no material passing the No. 10 mesh sieve.
2. All materials, other than broken or blasted unweathered rock, shall have a gradation in accordance with TABLE 733-12A *Select Granular Fill Slope Protection Gradation*.

<b>TABLE 733-12A SELECT GRANULAR FILL SLOPE PROTECTION GRADATION</b>	
<b>Sieve Size Designation</b>	<b>Percentage Passing by Weight</b>
24 in. maximum dimension	100
6 in. maximum dimension	90-100
2 in. square sieve	0-30
1/4 in. sieve	0-10

The gradation is evaluated at the project level.

**C. DURABILITY.** Provide material having a Magnesium Sulfate Soundness loss less than 35%.

**BASIS OF APPROVAL.** Sources will be approved in accordance with the geotechnical control procedure “*Procedure for the Control and Quality Assurance of Granular Materials*”.

A preceding source evaluation will be valid for the time identified in the manual. For sources without a current evaluation, samples shall be obtained under the direction of the Departmental Geotechnical Engineer and will be tested and evaluated by the Geotechnical Engineering Bureau.

**BASIS OF ACCEPTANCE.** Approved select granular fill slope protection backfill material from approved sources will be accepted upon successful completion of the gradation tests and Quality Assurance (QA) program indicating that the material conforms to the specification. If the QA program is not introduced, approved select granular fill slope protection backfill material will be accepted upon successful completion of the gradation tests.

**733-13 B SELECT GRANULAR SUBGRADE**

**SCOPE.** This specification covers the material requirements and methods of testing select granular subgrade material generally used for backfilling undercuts. The following materials are evaluated in this specification:

- 733.1301 – Select Granular Subgrade (Blasted Rock)
- 733.1302 – Select Granular Subgrade (Typical)
- 733.1303 – Select Granular Subgrade (RCA)
- 733.1304 – Select Granular Subgrade (RCA Mixture)
- 733.1305 – Select Granular Subgrade (RAP)

**SAMPLING.** Perform material tests and quality assurance methods pertaining to the backfill requirements in conformance with the procedures for non-stockpiled materials contained in the geotechnical control procedure “*Procedure for the Control and Quality Assurance of Granular Materials*”.

## SECTION 733 – EARTHWORK MATERIALS

## MATERIAL REQUIREMENTS.

**A. SOURCE.** Provide backfill material from an approved source in accordance with the geotechnical control procedure “*Procedure for the Control and Quality Assurance of Granular Materials*”.

**B. GRADATION.** Provide material consisting of rock, stone, slag, cobbles, or gravel, substantially free of shale or other soft, poor durability particles.

1. Well graded rock may be used for this item. Particles shall not exceed 12 in. in greatest dimension nor  $\frac{2}{3}$  of the loose lift thickness, whichever is less.

2. All materials, other than well graded rock, furnished under this item shall have no particles greater than 6 in. in maximum dimension. Of the portion passing the 4 in. square sieve, the material shall have a gradation in accordance with TABLE 733-13A *Select Granular Subgrade Gradation*.

TABLE 733-13A SELECT GRANULAR SUBGRADE GRADATION	
Sieve Size Designation	Percentage Passing by Weight
¼ in.	30-100
No. 40	0-50
No. 200	0-10

The gradation is evaluated at the project level.

**C. DURABILITY.** Provide material having a Magnesium Sulfate Soundness loss less than 35%.

**D RECYCLED MATERIALS.** The following materials are an acceptable replacement for natural material:

- **Alternate A.** Recycled Portland Cement Concrete Aggregate (RCA) meeting the requirements of §733-07 Recycled Portland Cement Concrete Aggregate, Alternate A.
- **Alternate B.** Recycled Portland Cement Concrete Aggregate (RCA) meeting the requirements of §733-07 Recycled Portland Cement Concrete Aggregate, Alternate B.
- **Alternate C.** Reclaimed Asphalt Pavement (RAP) meeting the requirements of §733-06 Reclaimed Asphalt Pavement for Earthwork and Subbase.

**BASIS OF APPROVAL.** Sources will be approved in accordance with the geotechnical control procedure “*Procedure for the Control and Quality Assurance of Granular Materials*”.

A preceding source evaluation will be valid for the time identified in the manual. For sources without a current evaluation, samples shall be obtained under the direction of the Departmental Geotechnical Engineer and will be tested and evaluated by the Geotechnical Engineering Bureau.

**BASIS OF ACCEPTANCE.** Approved select granular subgrade backfill material from approved sources will be accepted upon successful completion of the gradation tests and Quality Assurance (QA) program indicating that the material conforms to the specification. If the QA program is not introduced,



**SECTION 733 – EARTHWORK MATERIALS**

approved select granular subgrade backfill material will be accepted upon successful completion of the gradation tests.

**733-14 B SELECT STRUCTURAL FILL**

**SCOPE.** This specification covers the material requirements and methods of testing select granular fill material generally used for backfilling behind structures.

**SAMPLING.** The sampling procedure contained in §733-11 *Select Granular Fill* shall apply.

**MATERIAL REQUIREMENTS.** The material requirements contained in §733-11 *Select Granular Fill* shall apply.

**BASIS OF APPROVAL.** The basis of approval contained in §733-11 *Select Granular Fill* shall apply.

**BASIS OF ACCEPTANCE.** The basis of acceptance contained in §733-11 *Select Granular Fill* shall apply.

**733-15 B SAND BACKFILL**

**SCOPE.** This specification covers the material requirements and methods of testing sand backfill generally used for backfilling around utilities.

**SAMPLING.** Perform material tests and quality assurance methods pertaining to the backfill requirements in conformance with the procedures for non-stockpiled materials contained in the geotechnical control procedure “*Procedure for the Control and Quality Assurance of Granular Materials*”.

**MATERIAL REQUIREMENTS.**

**A. SOURCE.** Provide backfill material from an approved source in accordance with the geotechnical control procedure “*Procedure for the Control and Quality Assurance of Granular Materials*”.

**B. GRADATION.** Provide material have a gradation in accordance with TABLE 733-15A *Sand Backfill Gradation*.

<b>TABLE 733-15A SAND BACKFILL GRADATION</b>	
<b>Sieve Size Designation</b>	<b>Percentage Passing by Weight</b>
½ in.	100
¼ in.	90-100
No. 200	0-5

The gradation is evaluated at the project level.

**C. DURABILITY.** Provide materials substantially free of shale and soft, poor durability particles.

## SECTION 733 – EARTHWORK MATERIALS

**D. pH.** Where the State elects to test for this requirement, the material shall have a pH in accordance with TABLE 733-15B *Sand Backfill pH Requirement*.

TABLE 733-15B SAND BACKFILL pH REQUIREMENT		
Property	Test Method	Acceptance Criteria
pH	NYSDOT GTM-24	$5 \leq pH \leq 10$

**BASIS OF APPROVAL.** Sources will be approved in accordance with the geotechnical control procedure “*Procedure for the Control and Quality Assurance of Granular Materials*”.

A preceding source evaluation will be valid for the time identified in the manual. For sources without a current evaluation, samples shall be obtained under the direction of the Departmental Geotechnical Engineer and will be tested and evaluated by the Geotechnical Engineering Bureau.

**BASIS OF ACCEPTANCE.** Approved sand backfill material from approved sources will be accepted upon successful completion of the gradation tests and Quality Assurance (QA) program indicating that the material conforms to the specification. If the QA program is not introduced, approved sand backfill material will be accepted upon successful completion of the gradation tests.

## 733-16 B WINTER EARTHWORK

**SCOPE.** This specification addresses the material requirements and methods of assessing earthwork materials placed during construction operations between November 1<sup>st</sup> and April 1<sup>st</sup>. The following materials are evaluated in this specification:

- 733.1601 – Winter Earthwork Material for Embankment In Place
- 733.1602 – Winter Earthwork Material for Select Borrow
- 733.1603 – Winter Earthwork Material for Select Fill
- 733.160401 – Winter Earthwork Material for Select Granular Fill (Typical)
- 733.160402 – Winter Earthwork Material for Select Granular Fill for Corrugated Aluminum Pipe
- 733.160501 – Winter Earthwork Material for Select Granular Subgrade (Blasted Rock)
- 733.160502 – Winter Earthwork Material for Select Granular Subgrade (Typical)
- 733.160503 – Winter Earthwork Material for Select Granular Subgrade (RCA)
- 733.160504 – Winter Earthwork Material for Select Granular Subgrade (RCA Mixture)
- 733.1606 – Winter Earthwork Material for Select Structural Fill
- 733.1607 – Winter Earthwork Material for GRES Slope Backfill

**SAMPLING.** Perform material tests and quality assurance methods pertaining to the backfill requirements in conformance with the procedures contained in the geotechnical control procedure “*Procedure for the Control and Quality Assurance of Granular Materials*”.

**MATERIAL REQUIREMENTS.**

**A. SOURCE.** Provide unfrozen backfill material from an approved source in accordance with the geotechnical control procedure “*Procedure for the Control and Quality Assurance of Granular Materials*”.

**B. GRADATION.**

## SECTION 733 – EARTHWORK MATERIALS

**1. Winter Earthwork Material for Embankment In Place.** Provide material consisting of rock, stone, slag, cobbles, or gravel, substantially free of shale or other soft, poor durability particles. The material shall have no particles greater than 12 in. in maximum dimension. The material shall have a gradation in accordance with TABLE 733-16A Gradation of Winter Earthwork Material.

TABLE 733-16A GRADATION OF WINTER EARTHWORK MATERIAL	
Sieve Size Designation	Percentage Passing by Weight
Maximum Dimension	100
0.5(Maximum Dimension)	0-50
¼ in.	0-10
No. 200	0-4

The gradation is evaluated at the project level.

**2. Winter Earthwork Material for Select Borrow.** Provide material meeting the requirements of §733-09 *Select Borrow* with the following gradation adjustment:

The material shall have no particles greater than 3 ft. in maximum dimension. The material shall have a gradation in accordance with TABLE 733-16A Gradation of Winter Earthwork Material. The gradation is evaluated at the project level.

**3. Winter Earthwork Material for Select Fill.** The material requirements contained in §733-16 B.2. *Winter Earthwork Material for Select Borrow* shall apply.

**4. Winter Earthwork Material for Select Granular Fill.** Provide material meeting the requirements of §733-11 *Select Granular Fill* with the following gradation adjustment:

The material shall have no particles greater than 4 in. in maximum dimension. The material shall have a gradation in accordance with TABLE 733-16A Gradation of Winter Earthwork Material. The gradation is evaluated at the project level.

**5. Winter Earthwork Material for Select Granular Subgrade.** Provide material meeting the requirements of §733-13 *Select Granular Subgrade* with the following material and gradation adjustment:

The material shall have no particles greater than 6 in. in maximum dimension. The material shall have a gradation in accordance with TABLE 733-16A Gradation of Winter Earthwork Material. RAP shall not be used. The gradation is evaluated at the project level.

**6. Winter Earthwork Material for Select Structure Fill.** The material requirements contained in §733-16 B.4. *Winter Earthwork Material for Select Granular Fill* shall apply.

**7. Winter Earthwork Material for GRES Slope Backfill.** The material requirements contained in §733-16 B.5. *Winter Earthwork Material for Select Granular Subgrade* shall apply.

### C. CHARACTERISTICS.

1. No frozen material is to be incorporated into or be allowed to remain in any of the work.
2. Material of silt, clay, or high moisture content will not be permitted under any circumstances.

## SECTION 733 – EARTHWORK MATERIALS

**BASIS OF APPROVAL.** Sources will be approved in accordance with the geotechnical control procedure “*Procedure for the Control and Quality Assurance of Granular Materials*”.

A preceding source evaluation will be valid for the time identified in the manual. For sources without a current evaluation, samples shall be obtained under the direction of the Departmental Geotechnical Engineer and will be tested and evaluated by the Geotechnical Engineering Bureau.

**BASIS OF ACCEPTANCE.** Approved winter earthwork material from approved sources for the substitution of embankment in place, select borrow, select fill, select granular fill, select granular subgrade, select structural fill, or GRES slope backfill will be accepted upon successful completion of the gradation tests and Quality Assurance (QA) program indicating that the material conforms to the specification. If the QA program is not introduced, approved winter earthwork material will be accepted upon successful completion of the gradation tests.

**733-17 B SURFACE SETTLEMENT GAUGE**

**SCOPE.** This specification covers the material requirements and methods of installation of the embankment construction control device surface settlement gauge generally used for monitoring embankment construction. The following materials are evaluated in this specification:

733.1701 – Surface Settlement Gauge (Pipe Gauge)

733.1702 – Surface Settlement Gauge (Manometer Gauge)

**MATERIAL REQUIREMENTS.** Provide material in conformance with the geotechnical control procedure “*Settlement Gauges and Settlement Rods*” including:

**A. PIPE GAUGE.**

1. **Pipe.** Provide a minimum 2 ½ in. diameter metal pipe with steel flange meeting the requirements of §732-02 *Drive Pipe*. Provide a sufficient amount of pipe extensions to meet the rise requirements identified in the geotechnical control procedure “*Settlement Gauges and Settlement Rods*”.
2. **Base.** Provide either of the following:
  - a. **Steel.** Provide a minimum ¼ in. thick steel plate meeting the requirements of §715-01 *Structural Steel*.
  - b. **Wood.** Provide wood to the sizes shown in the geotechnical control procedure “*Settlement Gauges and Settlement Rods*” conforming to the requirements of §712-14 *Stress Graded Timber and Lumber*. Treat wood in accordance with §708-31 *Wood Preservative - Waterborne* and applied in conformance with American Wood Preservers Association (AWPA) Use Category Designation UC4B.

**B. MANOMETER GAUGE.** Provide materials specified for A. *Pipe Gauge* with the exception of the pipe extensions. To obtain readings from the buried device, provide the following connection:

**1. Interconnection.**

### SECTION 733 – EARTHWORK MATERIALS

- a. **Tubing.** Provide ½ in. O.D. polyethylene tubing indicated in the geotechnical control procedure “*Settlement Gauges and Settlement Rods*”.
  - b. **Sand.** Provide sand conforming to the requirement of §703-07 *Concrete Sand*.
  - c. **Fluid.** Provide a 50-50 mixture of ethylene glycol and water.
2. **Readout Box.** Provide wood to the sizes shown in the geotechnical control procedure “*Settlement Gauges and Settlement Rods*” conforming to the requirements of §712-14 *Stress Graded Timber and Lumber*. Treat wood in accordance with §708-31 *Wood Preservative - Waterborne* and applied in conformance with American Wood Preservers Association (AWPA) Use Category Designation UC4B.
  3. **Base.** Provide wood to the sizes shown in the geotechnical control procedure “*Settlement Gauges and Settlement Rods*” conforming to the requirements of §712-14 *Stress Graded Timber and Lumber*. Treat wood in accordance with §708-31 *Wood Preservative - Waterborne* and applied in conformance with American Wood Preservers Association (AWPA) Use Category Designation UC4B.

**BASIS OF APPROVAL.** The material shall be approved on the basis of manufacturer’s certification that the material conforms to the specification.

**BASIS OF ACCEPTANCE.** Approved material will be accepted upon successful assemblage and installation in accordance with the geotechnical control procedure “*Settlement Gauges and Settlement Rods*”.

#### 733-18 B SETTLEMENT ROD

**SCOPE.** This specification covers the material requirements and methods of installation of the embankment construction control device settlement rod generally used for monitoring embankment construction.

**MATERIAL REQUIREMENTS.** Provide material in conformance with the geotechnical control procedure “*Settlement Gauges and Settlement Rods*” including:

- A. **ROD.** Provide a minimum ½ in. diameter steel rod meeting the requirements of §709-01 *Bar Reinforcement, Grade 60*.
- B. **PIPE.** Provide a minimum 3 in. diameter metal pipe and cap meeting the requirements of §732-02 *Drive Pipe*.

**BASIS OF APPROVAL.** The material shall be approved on the basis of manufacturer’s certification that the material conforms to the specification.

**BASIS OF ACCEPTANCE.** Approved material will be accepted upon successful assemblage and installation in accordance with the geotechnical control procedure “*Settlement Gauges and Settlement*”

## SECTION 733 – EARTHWORK MATERIALS

Rods”.

### 733-19 B CORIAN® BACKFILL

**SCOPE.** This specification covers the material requirements and methods of assessing Corian® backfill material generally used as fill material.

**SAMPLING.** Perform material tests and assurance methods pertaining to the Corian® backfill requirements in conformance with the procedures for stockpiled granular materials contained in the geotechnical control procedure “*Procedure for the Control and Quality Assurance of Granular Materials*”.

#### MATERIAL REQUIREMENTS.

**A. STOCKPILE.** Stockpile Corian® backfill material in accordance with the procedures for stockpiled granular materials contained in the geotechnical control procedure “*Procedure for the Control and Quality Assurance of Granular Materials*”.

**B. GRADATION.** Provide Corian® crushed to a maximum particle size of 2 in. The material shall be subject to visual inspection by the Regional Geotechnical Engineer.

**BASIS OF APPROVAL.** Corian® backfill will be approved in accordance with the procedures for stockpiled granular materials contained in the geotechnical control procedure “*Procedure for the Control and Quality Assurance of Granular Materials*”.

The material shall be subject to visual inspection by the Regional Geotechnical Engineer.

**BASIS OF ACCEPTANCE.** Approved Corian® backfill material will be accepted upon successful completion of the Quality Assurance (QA) program indicating that the material conforms to the specification. If the QA program is not introduced, Corian® backfill material will be accepted upon the basis of the stockpile approval.

### 733-20 UNDERDRAIN FILTER MATERIAL

**SCOPE.** This specification covers the material requirements and methods of testing underdrain filter material generally used in drainage systems. The following underdrain filter types are evaluated in this specification:

733.2001 – Underdrain Filter, Type 1

733.2002 – Underdrain Filter, Type 2

Underdrain filter types are based on the gradation of the material as outlined in Table 733-20A *Underdrain Filter Material Gradation* or alternate recycled material as outlined in Table 733-20B *Underdrain Filter Material, Glass Substitution Gradation*.

**SAMPLING.** Perform material tests and assurance methods pertaining to underdrain filter material requirements in conformance with the procedures contained in the geotechnical control procedure “*Procedure for the Control and Quality Assurance of Granular Materials*”.

SECTION 733 – EARTHWORK MATERIALS

MATERIAL REQUIREMENTS.

**A. STOCKPILE.** Stockpile underdrain filter material in accordance with the geotechnical control procedure “*Procedure for the Control and Quality Assurance of Granular Materials*” except as noted herein.

**B. GRADATION.** Provide material consisting of crushed stone, sand, gravel, or screened gravel having a gradation in accordance with TABLE 733-20A *Underdrain Filter Material Gradation*.

TABLE 733-20A UNDERDRAIN FILTER MATERIAL GRADATION		
Sieve Size Designation	Percentage Passing by Weight	
	Type 1	Type 2
1 in.	100	-
½ in.	30-100	100
¼ in.	0-30	20-100
No. 10	0-10	0-15
No. 20	0-5	0-5

**C. DURABILITY.** Provide material meeting the soundness requirements of §703-02 *Coarse Aggregates* or §703-10 *Lightweight Aggregates*. When electing to use material from sources not approved under §703-02 or §703-10, provide material having a Magnesium Sulfate Soundness loss less than 20% in conformance with the procedures contained in the geotechnical test method “*Test Method for Magnesium Sulfate Soundness of Granular Materials*”.

**D. RECYCLED MATERIALS.** The following material is an acceptable replacement for Types 1 or 2.

- **Alternate A.** Crushed glass backfill. Glass shall meet the requirements of §733-05 Glass Backfill and have a gradation in accordance with TABLE 733-20B *Underdrain Filter Material, Glass Substitution Gradation*.

TABLE 733-20B UNDERDRAIN FILTER MATERIAL, GLASS SUBSTITUTION GRADATION	
Sieve Size Designation	Percentage Passing by Weight
½ in.	100
¾ in.	90 – 100
No. 200	0-5

**BASIS OF APPROVAL.** Stockpiles of underdrain filter material will be approved in accordance with the geotechnical control procedure “*Procedure for the Control and Quality Assurance of Granular Materials*”.

**BASIS OF ACCEPTANCE.** Underdrain filter material from approved stockpiles will be accepted upon successful completion of the Quality Assurance (QA) program indicating that the material conforms to the specification. If the QA program is not introduced, underdrain filter material will be accepted upon the basis of the stockpile approval.

## SECTION 733 – EARTHWORK MATERIALS

## 733-21 B STONE FILLING

**SCOPE.** This specification covers the material requirements and methods of testing stone filling generally used in stream bank channel protection. The following stone filling types are evaluated in this specification:

- 733.2101 – Stone Filling, Fine
- 733.2102 – Stone Filling, Light
- 733.2103 – Stone Filling, Medium
- 733.2104 – Stone Filling, Heavy

Stone filling types are based on the gradation of the material as outlined in Table 733-21A *Stone Filling Gradation* and Table 733-21B *Stone Filling Approximate Shape*.

**SAMPLING.** Perform material tests and assurance methods pertaining to stone filling requirements in conformance with the procedures contained in the geotechnical control procedure “*Procedure for the Control of Stone Filling and Rip-Rap Items*”.

**MATERIAL REQUIREMENTS.**

**A. STOCKPILE.** Stockpile stone filling in accordance with the geotechnical control procedure “*Procedure for the Control of Stone Filling and Rip-Rap Items*” except as noted herein.

**B. GRADATION.** Provide material having a gradation in accordance with TABLE 733-21A *Stone Filling Gradation* and Table 733-21B *Stone Filling Approximate Shape*.

TABLE 733-21A STONE FILLING GRADATION			
Stone Filling Item	See Notes	Stone Size	Percent of Total by Weight
Fine	2, 3, 4	Smaller than 8 in.	90-100
		Larger than 3 in.	50-100
		Smaller than No. 10 sieve	0-10
Light	2, 3, 4	Lighter than 100 lbs.	90-100
		Larger than 6 in.	50-100
		Smaller than ½ in.	0-10
Medium	2, 4	Heavier than 100 lbs.	50-100
		Smaller than 4 in.	0-10
Heavy	2, 4, 5	Heavier than 600 lbs.	50-100
		Smaller than 6 in.	0-10

## TABLE 733-21B STONE FILLING APPROXIMATE SHAPE

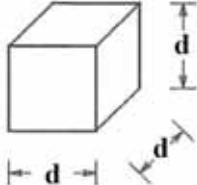
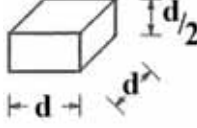
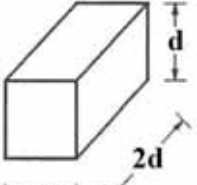
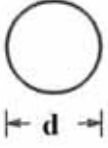
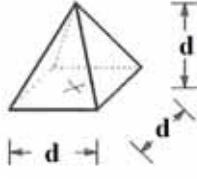

SECTION 733 – EARTHWORK MATERIALS

Specified Weights and Sizes				 sphere	
600 lbs.	d=18 in.	d=23 in.	d=15 in.	d=23 in.	d=27 in.
300 lbs.	d=15 in.	d=18 in.	d=12 in.	d=18 in.	d=21 in.
150 lbs.	d=12 in.	d=15 in.	d=9 in.	d=15 in.	d=17 in.
100 lbs.	d=10 in.	d=13 in.	d=8 in.	d=13 in.	d=15 in.
d = 8 in.	50 lbs.	25 lbs.	100 lbs.	25 lbs.	16 lbs.
d = 6 in.	20 lbs.	10 lbs.	40 lbs.	10 lbs.	7 lbs.

**Notes:**

1. Stone sizes, other than weights, refer to the average of the maximum and minimum dimensions of a stone particle as estimated by the Engineer.
2. Materials shall contain less than 20% of stones with a ratio of maximum to minimum dimension greater than three.
3. Air-cooled blast furnace slag, cobbles or gravel having at least one fractured face per particle are acceptable substitutes for stone under these items, provided that the soundness and gradation requirements are met.
4. Materials shall contain a sufficient amount of stones smaller than the average stone size to fill in the spaces between the larger stones.
5. Heavier gradings of this item may be required on some projects, in which case the requirements will be stated in the contract documents.

**C. DURABILITY.** The soundness of all material used for stone filling shall be approved on the basis of a geologic evaluation in accordance with the geotechnical control procedure “*Procedure for the Control of Stone Filling and Rip-Rap Items*”.

Where the State elects to conduct soundness tests, stone filling shall have a Magnesium Sulfate Soundness loss less than 10%, by weight, after 10 cycles.

**BASIS OF APPROVAL.** Stockpiles of stone filling will be approved in accordance with the geotechnical control procedure “*Procedure for the Control of Stone Filling and Rip-Rap Items*”.

**BASIS OF ACCEPTANCE.** Stone filling from approved stockpiles will be accepted upon successful completion of the Quality Assurance (QA) program indicating that the material conforms to the specification. If the QA program is not introduced, stone filling will be accepted upon the basis of the stockpile approval.

**733-22 B RIP-RAP**

**SCOPE.** This specification covers the material requirements and methods of testing rip-rap generally used in stream bank channel protection. The following rip-rap types are evaluated in this specification:

733.2201 – Dry Rip-Rap

## SECTION 733 – EARTHWORK MATERIALS

## 733.2202 – Grouted Rip-Rap

**SAMPLING.** Perform material tests and assurance methods pertaining to rip-rap requirements in conformance with the procedures contained in the geotechnical control procedure “*Procedure for the Control of Stone Filling and Rip-Rap Items*”.

**MATERIAL REQUIREMENTS.**

**A. STOCKPILE.** Stockpile rip-rap in accordance with the geotechnical control procedure “*Procedure for the Control of Stone Filling and Rip-Rap Items*” except as noted herein.

**B. GRADATION.** Provide material consisting of stones shaped as nearly as practicable in the form of right rectangular prisms having a gradation in accordance with TABLE 733-22A *Rip-Rap Gradation*. One dimension of each of the stones furnished shall be at least equal to the thickness of the rip-rap shown in the contract documents.

TABLE 733-22A RIP-RAP GRADATION	
Stone Weight	Gradation Spread
Heavier than 300 lbs.	50-100 percent of total by weight
100 lbs. $\leq \gamma \leq$ 300 lbs.	Remainder of stones

**C. DURABILITY.** The soundness of all material used for rip-rap shall be approved on the basis of a geologic evaluation in accordance with the geotechnical control procedure “*Procedure for the Control of Stone Filling and Rip-Rap Items*”.

Where the State elects to conduct soundness tests, rip-rap shall have a Magnesium Sulfate Soundness loss less than 10%, by weight, after 10 cycles.

**D. GROUT.** Provide grout manufacture materials conforming to Table 733-22B *Grouted Rip-Rap Grout Requirements*:

TABLE 733-22B GROUTED RIP-RAP GROUT REQUIREMENTS		
Material	Subsection	Grout Mix
Portland Cement Type 2	§701-01	1 part
Concrete Sand	§703-07	3 parts

**BASIS OF APPROVAL.** Stockpiles of rip-rap will be approved in accordance with the geotechnical control procedure “*Procedure for the Control of Stone Filling and Rip-Rap Items*”.

The material shall be subject to visual inspection by the Regional Geotechnical Engineer.

**BASIS OF ACCEPTANCE.** Rip-rap from approved stockpiles will be accepted upon successful completion of the Quality Assurance (QA) program indicating that the material conforms to the specification. If the QA program is not introduced, rip-rap will be accepted upon the basis of the stockpile approval

**733-23 B BEDDING MATERIAL**

**SECTION 733 – EARTHWORK MATERIALS**

**SCOPE.** This specification covers the material requirements and methods of testing bedding material generally used as a foundation material prior to placing stone filling or rip-rap.

**SAMPLING.** Perform material tests and assurance methods pertaining to bedding material requirements in conformance with the procedures contained in the geotechnical control procedure “*Procedure for the Control and Quality Assurance of Granular Materials*”.

**MATERIAL REQUIREMENTS.**

**A. STOCKPILE.** Stockpile bedding material in accordance with the geotechnical control procedure “*Procedure for the Control and Quality Assurance of Granular Materials*” except as noted herein.

**B. GRADATION.** Provide material consisting of crushed stone, crushed air-cooled blast furnace slag, or gravel, free of soft, non-durable particles, organic material, and thin or elongated particles having a gradation in accordance with TABLE 733-23A *Bedding Material Gradation*.

<b>TABLE 733-23A BEDDING MATERIAL GRADATION</b>	
<b>Sieve Size Designation</b>	<b>Percentage Passing by Weight</b>
4 in.	100
1 in.	15-60
¼ in.	0-25
No. 40	0-10

**BASIS OF APPROVAL.** Stockpiles of bedding material will be approved in accordance with the geotechnical control procedure “*Procedure for the Control and Quality Assurance of Granular Materials*”.

**BASIS OF ACCEPTANCE.** Bedding material from approved stockpiles will be accepted upon successful completion of the Quality Assurance (QA) program indicating that the material conforms to the specification. If the QA program is not introduced, bedding material will be accepted upon the basis of the stockpile approval.

**SECTION 734 (VACANT)**

## SECTION 737 – GEOSYNTHETICS

Make the following changes to the Standard Specifications dated May 1, 2008:

**Replace** Section 737 in its entirety with the following:

### SECTION 737 B GEOSYNTHETICS

**QUALITY ASSURANCE PROGRAM.** The Department maintains a Quality Assurance (QA) program for geosynthetics. For monitoring purposes, the Geotechnical Engineering Bureau will test a sample of the geosynthetic material delivered to the project site to compare its properties to those properties determined at the time of the product's initial approval, which may indicate a change has occurred in the manufacturer's process or Quality Control (QC) process.

Several scenarios may develop as a result of the QA testing.

1. The properties are shown to be the same as originally determined within the statistical validity of the test. No action will be taken.
2. The properties are shown to be significantly different than originally determined.
  - a. If the results are within the acceptable minimum for approval, contact with the manufacturer will be made by the Geotechnical Engineering Bureau to determine what has changed.
  - b. If the results are below the minimum acceptable for approval, the product's status on the Approved List will be re-evaluated. The manufacturer will be notified of the review.

### 737-01 GEOTEXTILES

**SCOPE.** This specification covers the material requirements and methods of testing geosynthetic materials used in highway construction. The following Geotextile Structure Types are evaluated in this specification:

737.0101 – Needle-Punched – Non-Woven	(NP – NW)
737.0102 – Heatbonded – Non-Woven	(HB – NW)
737.0103 – Monofilament - Woven	(MF – W)
737.0104 – Multifilament – Woven	(MuF – W)
737.0105 – Slit Film – Woven	(SF – W)
737.0106 – Combination Monofilament/Fibrillated Yarn – Woven	(C – W)
737.0107 – Recycled/ Reinforced Needle-Punched – Non-Woven	(R/R NP – NW)
737.0108 – Circular – Woven	(Cir – W)

**GENERAL.** The Department's evaluation of geotextiles submitted will be based on the following tests:

1. Soil Retention - The test to evaluate this characteristic will be performed in accordance with the Apparent Opening Size Test, ASTM D4751.
2. Flow Capacity - The test to evaluate this characteristic will be performed in accordance with the Permittivity Test, ASTM Method D4491.
3. Tensile Strength - The tests to evaluate this characteristic will be performed in accordance with the following:
  - a. Grab Test Method, ASTM D4632
  - b. Trapezoid Tear Test Method, ASTM D4533
  - c. Static Puncture Strength Using a 2 in. Probe, ASTM D6241

**SECTION 737 – GEOSYNTHETICS**

**Applications.** Based on the above tests and criteria that follow, the Geotextiles may be accepted for the following:

- Geotextile Bedding
- Geotextile Separation
- Geotextile Drainage
- Geotextile Slope Protection
- Geotextile Stabilization
- Turbidity Curtains
- Silt Fence

**MATERIAL REQUIREMENTS.** Following is a table of the requirements by applications:

**A. Geotextile Bedding.** Geotextile bedding shall meet the requirements of Table 737-01A.

Table 737-01A Bedding Geotextile Requirements										
Application	Geotextile Structure	Minimum Strength Class Requirements					Bedding Class Requirements			
		Class	Percent Elongation (%)	Grab Strength (lbf)	Tear Strength (lbf)	Puncture Strength (lbf)	Class	Apparent Opening Size (maximum)		Minimum Permittivity (sec <sup>-1</sup> )
								Sieve Size (in.)	Sieve Designation	
Geotextile Bedding	C – W	1	< 50%	315	112	618	A	0.0165	No. 40	0.7
			≥ 50%	202	79	433	B	0.0098	No. 60	0.2
	MF - W	2	< 50%	247	56	495	C	0.0083	No. 70	0.1
			≥ 50%	157	56	309				

**B. Geotextile Separation.** Geotextile separation shall meet the requirements of Table 737-01B.

Table 737-01B Separation Geotextile Requirements										
Application	Geotextile Structure	Minimum Strength Class Requirements					Separation Class Requirements			
		Class	Percent Elongation (%)	Grab Strength (lbf)	Tear Strength (lbf)	Puncture Strength (lbf)	Class	Apparent Opening Size (maximum)		Minimum Permittivity (sec <sup>-1</sup> )
								Sieve Size (in.)	Sieve Designation	
Geotextile Separation	Any type listed in §737-01 Scope	2	< 50%	247	90 <sup>1</sup>	495	NA (X)	0.0234	No. 30	0.02
			≥ 50%	157	56	309				

Table 737-01B Notes:

<sup>1</sup> For woven monofilament geotextiles the minimum average value is 56 lbf.

## SECTION 737 – GEOSYNTHETICS

**C. Geotextile Drainage.** Geotextile drainage shall meet the requirements of Table 737-01C.

Table 737-01C Drainage Geotextile Requirements										
Application	Geotextile Structure	Minimum Strength Class Requirements					Drainage Class Requirements			
		Class	Percent Elongation (%)	Grab Strength (lbf)	Tear Strength (lbf)	Puncture Strength (lbf)	Class	Apparent Opening Size (maximum)		Minimum Permittivity (sec <sup>-1</sup> )
								Sieve Size (in.)	Sieve Designation	
Geotextile Drainage	Non-Woven	2	< 50%	247	90	495	A	0.0165	No. 40	0.5
			≥ 50%	157	56	309	B	0.0098	No. 60	0.2
							C	0.0083	No. 70	0.1

**D. Geotextile Slope Protection.** Geotextile slope protection shall meet the requirements of Table 737-01D.

Table 737-01D Slope Protection Geotextile Requirements										
Application	Geotextile Structure	Minimum Strength Class Requirements					Slope Protection Class Requirements			
		Class	Percent Elongation (%)	Grab Strength (lbf)	Tear Strength (lbf)	Puncture Strength (lbf)	Class	Apparent Opening Size (maximum)		Minimum Permittivity (sec <sup>-1</sup> )
								Sieve Size (in.)	Sieve Designation	
Geotextile Slope Protection	NP - NW	1	< 50%	315	112	618	A	0.0165	No. 40	0.7
			≥ 50%	202	79	433	B	0.0098	No. 60	0.2
							C	0.0083	No. 70	0.1

**E. Geotextile Stabilization.** Geotextile stabilization shall meet the requirements of Table 737-01E.

Table 737-01E Stabilization Geotextile Requirements										
Application	Geotextile Structure	Minimum Strength Class Requirements					Stabilization Class Requirements			
		Class	Percent Elongation (%)	Grab Strength (lbf)	Tear Strength (lbf)	Puncture Strength (lbf)	Class	Apparent Opening Size (maximum)		Minimum Permittivity (sec <sup>-1</sup> )
								Sieve Size (in.)	Sieve Designation	
Geotextile Stabilization	Any type listed in §737-01 Scope	1	< 50%	315	112	618	NA (X)	0.0165	No. 40	0.05
			≥ 50%	202	79	433				

SECTION 737 – GEOSYNTHETICS

**F. Turbidity Curtain.** Turbidity curtains shall meet the requirements of Table 737-01F.

Table 737-01F Turbidity Curtain Requirements										
Application	Geotextile Structure	Minimum Strength Class Requirements					Turbidity Curtain Class Requirements			
		Class	Percent Elongation (%)	Grab Strength (lbf)	Tear Strength (lbf)	Puncture Strength (lbf)	Class	Apparent Opening Size (maximum)		Minimum Permittivity (sec <sup>-1</sup> )
								Sieve Size (in.)	Sieve Designation	
Turbidity Curtain	Any type listed in §737-01 Scope	2	< 50%	247	90 <sup>1</sup>	495	NA (X)	0.0117	No. 50	0.4
			≥ 50%	157	56	309				

Table 737-01F Notes:

<sup>1</sup> For woven monofilament geotextiles the minimum average value is 56 lbf.

**G. Silt Fence.** Silt fences shall meet the requirements of Table 737-01G.

Table 737-01G Silt Fence Requirements											
Application	Geotextile Structure	Minimum Strength Class Requirements						Silt Fence Class Requirements			
		Max. Post Spacing (ft.)	Percent Elongation (%)	Grab Strength (lbf)	Orientation <sup>3</sup>	Fence Between Posts	Designation	Class	Apparent Opening Size (maximum)		Minimum Permittivity (sec <sup>-1</sup> )
									Sieve Size (in.)	Sieve Desig.	
Silt Fence	Any type listed in §737-01 Scope	4.0	NA	90	MD	Supported <sup>1</sup>	s	NA (X)	0.0234	No. 30	0.05
					XD						
		4.0	≥ 50% <sup>2</sup>	123	MD	Unsupported	us 4.0				
					XD						
		6.5	< 50% <sup>2</sup>	123	MD	Unsupported	us 6.5				
					XD						

Table 737-01G Notes:

<sup>1</sup> Silt fence support shall consist of 14 gage steel wire with a mesh spacing of 6 in. x 6 in. or prefabricated polymeric mesh with a minimum ultimate tensile strength of 200 lb/ft in both machine and cross machine directions measured in accordance with ASTM D6637.

<sup>2</sup> As measured in accordance with ASTM D4632.

<sup>3</sup> MD = Machine Direction, XD = Cross-Machine Direction.

**BASIS OF APPROVAL.** All geotextiles, including those sold under a private label agreement, being submitted for testing and approval must be submitted through the American Association of State Highway and Transportation Officials (AASHTO) National Transportation Product Evaluation Program

## SECTION 737 – GEOSYNTHETICS

(NTPEP). The program has four submittal periods per calendar year. Information regarding submittal is available at the address shown below:

AASHTO-NTPEP Coordinator  
444 N. Capitol St., NW, Suite 249  
Washington, DC 20001

The approval criterion for geotextiles is based on AASHTO M-288 *Specification for Geotextiles* and the NTPEP Report.

Approved geotextiles will be added to the Approved List.

**BASIS OF ACCEPTANCE.** Geotextiles will be accepted on the basis of:

1. The roll of material being properly identified either by a label on the geotextile or the container. The container may be either the cover wrapping or the core around which the geotextile is rolled,
2. The material brand name and style appearing on the Approved List for the intended application,
3. The material certification submitted with the geotextile stating that the material conforms to the specification and that it is the same one appearing on the Approved List, and
4. The swatch of the submitted geotextile successfully passing a visual inspection by the Regional Geotechnical Engineer.

### 737-02 GEOMEMBRANES

**SCOPE.** This specification covers the material requirements and methods of testing geomembranes used in highway construction.

**GENERAL.** The Department's evaluation of geomembranes submitted will be based on the following tests:

1. Tensile Strength - Test in accordance with ASTM D4632, Grab Test Method.
2. Elongation - Test in accordance with ASTM D4632.
3. Trapezoidal Tear Resistance - Test in accordance with ASTM D4535, Trapezoid Tear Test Method.
4. Puncture - Test in accordance with ASTM D4833, Index Puncture Resistance.

**MATERIAL REQUIREMENTS.** Geomembranes shall meet the following requirements:

1. Ultimate Tensile Strength – 180 lbf<sup>(1)</sup>
  2. Ultimate Elongation - 65%<sup>(1)</sup>
  3. Trapezoid Tear Resistance - 60 lbf<sup>(1)</sup>
  4. Puncture - 90 lbf<sup>(2)</sup>
- <sup>(1)</sup> Minimum value in weaker principal direction. The average of the test results in the weaker principal direction shall be equal to or greater than the stated values.
- <sup>(2)</sup> The average of the test results for puncture shall meet or exceed the stated value.

**BASIS OF APPROVAL.** Producers of geomembranes shall demonstrate the quality of their products before being placed on the Department's Approved List. The producer shall provide:

1. A completed Form Number SM 465 *Product Evaluation Form*.
2. A test data sheet identifying the geomembrane properties.



### SECTION 737 – GEOSYNTHETICS

3. A 20 sq yd sample of geomembrane to allow for testing by the Department.

Approved geomembranes will be added to the Approved List.

**BASIS OF ACCEPTANCE.** Geomembranes will be accepted on the basis of:

1. The roll of material being properly identified either by a label on the geomembrane or the container. The container may be either the cover wrapping or the core around which the geomembrane is rolled,
2. The material brand name and style appearing on the Approved List for the intended application, and
3. The material certification submitted with the geomembrane stating that the material conforms to the specification and that it is the same one appearing on the Approved List.

### 737-03 PREFABRICATED VERTICAL DRAINS

**SCOPE.** This specification covers the material requirements and methods of testing prefabricated vertical drains used in highway construction.

**GENERAL.** The Department's evaluation of prefabricated vertical drains submitted will be based on the following tests:

1. Prefabricated Vertical Drain:
  - a. Equivalent Sand Drain Diameter - Test in accordance with NYSDOT - GEB Large Diameter Consolidation Test.
2. Cover Geotextile Wrapping:
  - a. The requirements listed in Geotextile Drainage (Table 737-01C).

**MATERIAL REQUIREMENTS.** Prefabricated Vertical Drains shall meet the following requirements:

1. Prefabricated Vertical Drain:
  - a. Equivalent Sand Drain Diameters – 1 ½ in. minimum.<sup>(1)</sup>
2. Cover Geotextile Wrapping:
  - a. The requirements listed in Geotextile Drainage (Table 737-01C). The geotextile shall be tightly wrapped around the core.

<sup>(1)</sup> The average of the test results shall meet or exceed the stated values.

**BASIS OF APPROVAL.** Producers of prefabricated vertical drains shall demonstrate the quality of their products before being placed on the Department's Approved List. The producer shall provide:

1. A completed Form Number SM 465 *Product Evaluation Form*.
2. A test data sheet identifying the cover geotextile and core and their properties.
3. A 30 ft. long sample of the prefabricated vertical drain to allow for testing by the Department.

Approved prefabricated vertical drains will be added to the Approved List.

**BASIS OF ACCEPTANCE.** Prefabricated vertical drains will be accepted on the basis of:

1. The roll of material being properly identified either by a label on the prefabricated vertical drain or the container. The container may be either the cover wrapping or the core around which the prefabricated vertical drain is rolled,

### SECTION 737 – GEOSYNTHETICS

2. The material brand name and style appearing on the Approved List for the intended application,
3. The material certification submitted with the prefabricated vertical drain stating that the material conforms to the specification and that it is the same one appearing on the Approved List, and
4. The letter, accompanying the material certification, identifying the cover geotextile wrapping demonstrates that the geotextile appears on the Approved List for Geotextile Drainage.

#### 737-04 PREFABRICATED COMPOSITE STRUCTURAL DRAINS

**SCOPE.** This specification covers the material requirements and methods of testing prefabricated composite structural drains (PCSD's)<sup>(1)</sup> used in highway construction.

**GENERAL.** The Department's evaluation of PCSD's submitted will be based on the following tests:

1. PCSD: Flow Capacity Under Load - Test in accordance with ASTM D4716, Test Method for Determining the (In-plane) Flow Rate per Unit Width and Hydraulic Transmissivity of a Geosynthetic Using a Constant Head.
2. Cover Geotextile Wrapping: The requirements listed in Geotextile Drainage (Table 737-01C).

**MATERIAL REQUIREMENTS.** The PCSD shall meet the following requirements:

1. PCSD:
  - a. Hydraulic Transmissivity
    - i. For impermeable cores, where flow is allowed on both sides, the hydraulic transmissivity shall be 4.0 gal./min./ft. of width under 1500 psf and a hydraulic gradient of 0.1<sup>(2)</sup>.
    - ii. For permeable cores, or one sided flow impermeable cores, the hydraulic transmissivity shall be 2.0 gal./min./ft. of width under 1500 psf and a hydraulic gradient of 0.1<sup>(2)</sup>.
2. Cover Geotextile Wrapping:
  - a. The requirements listed in Geotextile Drainage (Table 737-01C) Class A. The geotextile shall be bonded to the core.

<sup>(1)</sup> This includes prefabricated composite structural drains used as integral abutment drains.

<sup>(2)</sup> The average of the test results shall meet or exceed the stated values.

**BASIS OF APPROVAL.** Producers of PCSD's shall demonstrate the quality of their products before being placed on the Department's Approved List. The producer shall provide:

1. A completed Form Number SM 465 *Product Evaluation Form*.
2. A test data sheet identifying the properties of the protective geotextile and the core.
3. A 16 sq. ft. sample of the PCSD drain to allow for testing by the Department.

Approved PCSD's will be added to the Approved List.

**BASIS OF ACCEPTANCE.** PCSD's will be accepted on the basis of:

1. The roll of material being properly identified either by a label on the PCSD or the container. The container may be either the cover wrapping or the core around which the PCSD is rolled,
2. The material brand name and style appearing on the Approved List for the intended application,
3. The material certification submitted with the PCSD stating that the material conforms to the specification and that it is the same one appearing on the Approved List, and

## SECTION 737 – GEOSYNTHETICS

4. The letter, accompanying the material certification, identifying the cover geotextile wrapping demonstrates that the geotextile appears on the Approved List for Geotextile Drainage.

### 737-05 PREFABRICATED COMPOSITE INTEGRAL ABUTMENT DRAINS

**SCOPE.** This specification covers the material requirements and methods of testing prefabricated composite integral abutment drains (PCIAD's) used in highway construction.

**GENERAL.** PCIAD's shall meet the requirements of PCSD except that the minimum thickness of the PCIAD shall be 0.4 in. as measured by ASTM D5199.

**BASIS OF APPROVAL.** Producers of PCIAD's shall demonstrate the quality of their products before being placed on the Department's Approved List. The approval procedure for PCIAD's follows the approval procedure for PCSD's.

Approved PCIAD's will be added to the Approved List.

**BASIS OF ACCEPTANCE.** PCIAD's will be accepted on the basis of:

1. The roll of material being properly identified either by a label on the PCIAD or the container. The container may be either the cover wrapping or the core around which the PCIAD is rolled,
2. The material brand name and style appearing on the Approved List for the intended application,
3. The material certification submitted with the PCIAD stating that the material conforms to the specification and that it is the same one appearing on the Approved List, and
4. The letter, accompanying the material certification, identifying the cover geotextile wrapping demonstrates that the geotextile appears on the Approved List for Geotextile Drainage.

### 737-06 PREFABRICATED COMPOSITE EDGE DRAINS

**SCOPE.** This specification covers the material requirements and methods of testing prefabricated composite edge drains (PCED's) used in highway construction.

**GENERAL.** The Department's evaluation of PCED's submitted will be based on the following tests:

1. PCED:
  - a. Flow Capacity - Test in accordance with ASTM D4716, Test Method for Determining the (In-plane) Flow Rate per Unit Width and Hydraulic Transmissivity of a Geosynthetic Using a Constant Head.
2. Cover Geotextile Wrapping:
  - a. The requirements listed in Geotextile Drainage (Table 737-01C).

**MATERIAL REQUIREMENTS.** PCED's shall meet the following requirements:

1. PCED:
  - a. Flow Capacity – 15 gal./min./ft. of width when tested at a 10 psi load after 100 hours, at a hydraulic gradient of 0.1. If the flow channel is separated into two or more parts, only the flow rate of the section facing the pavement will be considered.
2. Cover Geotextile Wrapping:
  - a. The requirements listed in Geotextile Drainage (Table 737-01C). The geotextile shall be

### SECTION 737 – GEOSYNTHETICS

bonded to the core or tightly wrapped around the core.

**BASIS OF APPROVAL.** Producers of PCED's shall demonstrate the quality of their products before being placed on the Department's Approved List. The producer shall provide:

1. A completed Form Number SM 465 *Product Evaluation Form*.
2. A test data sheet identifying the cover geotextile and core and their properties.
3. A 16 sq. ft. sample of the PCED.

Approved PCED's will be added to the Approved List.

**BASIS OF ACCEPTANCE.** PCED's will be accepted on the basis of:

1. The roll of material being properly identified either by a label on the PCED or the container. The container may be either the cover wrapping or the core around which the PCED is rolled,
2. The material brand name and style appearing on the Approved List for the intended application,
3. The material certification submitted with the PCED stating that the material conforms to the specification and that it is the same one appearing on the Approved List, and
4. The letter, accompanying the material certification, identifying the cover geotextile wrapping demonstrates that the geotextile appears on the Approved List for Geotextile Drainage.

#### 737-07 GEOGRIDS

**SCOPE.** This specification covers the material requirements and methods of testing geogrids used in highway construction.

**GENERAL.** Submit the geogrid material certification with the material. Include in the certification the geogrid manufacturer's name, the geogrid name, the test lot number, the minimum average roll value for Ultimate Tensile Strength, the long-term design tensile strength, and the reduction factors used to calculate the long-term design tensile strength. The following definitions apply:

- A.  $T_D$ .** Long Term Design Tensile Strength =  $T_{ULT}/RF$ .
- B.  $T_{ULT}$ .** Ultimate Tensile Strength. Determined in the primary strength direction in accordance with ASTM D4595 or D6637, based on the Minimum Average Roll Value (MARV), per ASTM D4759, for the product.
- C.  $RF$ .** Total Reduction Factor =  $RF_{CR} \times RF_{ID} \times RF_{DU}$ . The minimum RF value permitted is 3.0.
- D.  $RF_{CR}$ .** Reduction Factor for Creep Deformation for 100 Year Design Life. Calculated in accordance with Geosynthetic Research Institute Standard Practice GRI-GG4 using ASTM D5262 to determine long term strength,  $T_{LT}$ , and ASTM D4595 to determine short term strength,  $T_{ST}$ .
- E.  $RF_{ID}$ .** Reduction Factor For Installation Damage Calculated in Accordance with Geosynthetic Research Institute Standard Practice GRI-GG4. The minimum tested  $RF_{ID}$  value permitted is 1.1.
- F.  $RF_{DU}$ .** Reduction Factor for Durability. Determined in Accordance with EPA9090 and ASTM D4595. The minimum tested  $RF_{DU}$  value permitted is 1.1.

**MATERIAL REQUIREMENTS.** Geogrid reinforcing shall be tested and certified to meet the minimum requirements for geosynthetic products in accordance with AASHTO Specifications for Highway Bridges, *Geosynthetic Reinforcement*.

**SECTION 737 – GEOSYNTHETICS**

**BASIS OF ACCEPTANCE.** Geogrids will be accepted on the basis of:

1. A material certification identifying:
  - a. The geogrid manufacturer’s name,
  - b. The geogrid name,
  - c. The test lot number,
  - d. The minimum average roll value for Ultimate Tensile Strength,
  - e. The long-term design tensile strength, and
  - f. The reduction factors used to calculate the long-term design tensile strength.
2. An evaluation that the information on the material certification meets the minimum requirements for the geogrids stated in the contract documents.

**737-08 GEOCELLS**

**SCOPE.** This specification covers the material requirements and methods of testing geocells used in highway construction.

**GENERAL.** Submit the geocell material certification with the material. Include in the certification the geocell manufacturer’s name, the geocell name, the test lot number, the minimum thickness, the cell seam peel strength, the ultraviolet stability, and the environmental stress crack resistance.

**MATERIAL REQUIREMENTS.** Geocells shall be made of High Density Polyethylene (HDPE) of the size(s) and dimensions shown in the contract documents. Geocells shall be tested and certified to meet the minimum requirements listed in Table 737-08 *Geocell Requirements*.

<b>TABLE 737-08 GEOCELL REQUIREMENTS</b>		
<b>Property</b>	<b>Test Method</b>	<b>Requirement</b>
Thickness	ASTM D 5199	0.04 in. minimum
Cell Seam Peel Strength	Per U.S. Army Corps of Engineers Technical Report GL-86-19 Appendix A	56 lbf per inch of cell depth, minimum
Ultraviolet Stability	ASTM D 1603 or ASTM D 4218	1.5 % by weight carbon black minimum
Environmental Stress Crack Resistance	ASTM D 1693	2000 hrs minimum

Geocells will be perforated with the exception of the fascia, which will be solid and green in color.

**BASIS OF ACCEPTANCE.** Geocells will be accepted on the basis of

1. A material certification identifying:
  - a. The geocell manufacturer’s name,
  - b. The geocell name,
  - c. The test lot number,
  - d. The minimum thickness,
  - e. The cell seam peel strength,

### SECTION 737 – GEOSYNTHETICS

- f. The ultraviolet stability, and
  - g. The environmental stress crack resistance.
2. An evaluation that the information on the material certification meets the minimum requirements for the geogrids stated in Table 737-08 and the contract documents.

#### 737-09 GEOSYNTHETIC FIBERS

**SCOPE.** This specification covers the material requirements and methods of testing geosynthetic fibers used in highway construction.

**GENERAL.** Submit the geosynthetic fiber material certification with the material. Include in the certification the geosynthetic fiber manufacturer's name, the geosynthetic fiber name, the test lot number, the polypropylene percentage, fiber length, specific gravity, carbon black content, tensile strength, tensile elongation and Young's modulus.

**MATERIAL REQUIREMENTS.** Geosynthetic fibers shall consist of fibrillated polypropylene strands and shall be tested and certified to meet the minimum requirements listed in Table 737-09 *Geosynthetic Fiber Requirements*.

TABLE 737-09 GEOSYNTHETIC FIBER REQUIREMENTS		
Property	Test Method	Requirement
Polypropylene	ASTM D4101 Group 1/ Class 1/ Grade 2	99.4 % minimum
Fiber Length	Measured	1 inch
Specific Gravity	ASTM D792	0.033 lb/in <sup>3</sup>
Carbon black Content	ASTM D1603	0.6 % minimum
Tensile Strength	ASTM D2256	45 ksi minimum
Tensile Elongation	ASTM D2256	15 % maximum
Young's Modulus	ASTM D2101	700 ksi minimum

**BASIS OF ACCEPTANCE.** Geosynthetic fibers will be accepted on the basis of

1. A material certification identifying:
  - a. The geosynthetic fiber manufacturer's name,
  - b. The geosynthetic fiber name,
  - c. The test lot number,
  - d. The polypropylene percentage,
  - e. The fiber length,
  - f. The specific gravity,
  - g. The carbon black content,
  - h. The tensile strength,
  - i. The tensile elongation, and
  - j. Young's modulus.
2. An evaluation that the information on the material certification meets the minimum requirements for the geosynthetic fiber stated in Table 737-09 *Geosynthetic Fiber Requirements* and the contract documents.

<b>SPECIAL NOTES</b>
----------------------

Location Maps

---

Landscape Development Notes

---

R.O.W.

---

Thruway

---

Canal

---

Funding

---

Specialty Items

---

Other Special Notes

---

Other Project Special Notes

---

---

---

---

---

---

---

---

---

---

*NOTE: This form was developed for repetitive use throughout all contract proposals and may identify items not applicable to this specific project.*

**SPECIAL NOTE  
MODIFICATION TO INSURANCE REQUIREMENTS**

The Contractor will not be required to provide Builder's Risk insurance coverage as required by the revised §107-06 *Insurance* inserted in the contract proposal.

Where required for professional services requiring the signature, stamp or certification of a licensed professional, the Contractor shall provide insurance coverage for Professional Liability/Errors and Omissions in accordance with §107-06B.8. *Professional Liability/Errors and Omissions*. The insurance coverage for this contract shall be not less than \$1,000,000 per claim and \$1,000,000 in the aggregate.



SPECIAL NOTE - Special Specification Pay Item Numbers

The contractor’s attention is directed to the special specification pay item formats used in this contract. Special specification pay items may be presented in three different formats:

- Format 1. Pay items for a special specification will have five digits to the left of the decimal point and up to six digits to the right of the decimal point. The two left-most digits represent the origin of the specification. Reference Standard Specification §101-02 Specifications.
- Format 2. Pay items for a special specification will have three digits to the left of the decimal point and up to eight digits to the right of the decimal. Spaces may appear in the third to sixth places after the decimal. The 7th and 8th digits to the right of the decimal will represent the origin of the specification.
- Format 3. Pay items for a special specification will have three digits to the left of the decimal point and up to eight digits to the right of the decimal. Dashes may appear in the third to sixth places after the decimal. The 7th and 8th digits to the right of the decimal will represent the origin of the specification.

Where items in this contract appear in multiple formats, the formats shall be equated to each other as illustrated below:

Format 1	Format 2	Format 3
xxxxx . xx	xxx . xx    xx	xxx . xx --- xx
xxxxx . xxxx	xxx . xxxx   xx	xxx . xxxx -- xx
xxxxx . xxxxxx	xxx . xxxxxxxx	xxx . xxxxxxxx

## SPECIAL NOTES

## GREEN CONSTRUCTION REQUIREMENTS

ULTRA LOW SULFUR DIESEL FUEL

In order to reduce diesel emissions, the Contractor shall use Ultra Low Sulfur Diesel (ULSD) fuel to operate all diesel engines used to complete the work that will operate for 10 hours or more on the contract site. ULSD fuel requirements shall apply to:

- All diesel engines/equipment.
- Stationary and mobile equipment.
- Owned, leased and rented equipment.

The hours the piece of equipment is used to complete the work is defined as the actual time the engine is running. The time may be continuous or discontinuous and includes warm-up periods idling, in traffic periods, etc.

The term "Contractor" is intended to mean both Prime Contractors and Subcontractors. Materials delivery vehicles not owned by the Contractor/Subcontractor are exempt from this requirement, but should minimize idling time at construction sites when ever possible.

The Contractor will be notified when any diesel powered construction equipment is in non-compliance. Non-compliance shall be corrected within a 24-hour period.

## SPECIAL NOTES

## GREEN CONSTRUCTION REQUIREMENTS

CONTROLLING EXPOSURE TO DIESEL EXHAUST

The Contractor shall exercise measures to protect “Sensitive Receptors” from the impacts of diesel exhaust fumes. Sensitive Receptors include, but are not limited to: hospitals, schools, daycare facilities, building fresh air or ventilation intakes, elderly housing or convalescent facilities. The Contractor shall ensure that diesel powered engines are located away from building air conditioners and windows.

The goal is to minimize exposure of Sensitive Receptors in close proximity to diesel exhaust, in terms of both concentration and time. In general, close proximity is defined as within 15 meters of a Sensitive Receptor. Mitigation techniques include positioning stationary equipment exhausts greater than 15 meters from Sensitive Receptors, extension of equipment exhausts through the use of flexible tubing; protecting building air intakes; and the use of moving operations.

Idling time for diesel powered equipment shall be limited to three consecutive minutes for delivery and dump trucks and all other diesel powered equipment except as follows:

- When a “mobile source” (vehicle) is forced to remain motionless because of traffic conditions or mechanical difficulties over which the operator has no control.
- When it is necessary to operate a loading, unloading or processing device.
- When the outdoor temperature is less than - 3°C (27°F).
- When the “mobile source” is being repaired.

Arrow panels and portable variable message signs shall be solar powered wherever possible or practical.

Whenever possible and practicable, the Contractor shall establish staging areas for diesel powered vehicles waiting to load or unload materials at the work site. Such areas shall be located where diesel emissions have the least impact on Sensitive Receptors and the general public.

## SPECIAL NOTES

## GREEN CONSTRUCTION REQUIREMENTS

DUST CONTROL

The Contractor shall minimize dust from disturbed soil surfaces or other materials that can cause off-site damage, health hazards and traffic safety problems. Dusty conditions resulting from the Contractor's operations shall be corrected at no additional cost to the State. Buffer areas of vegetation should be left where practical. Water quality shall be considered when selecting materials for dust control. An approved dust palliative may be used in conformance with applicable conditions placed on its use. A list of acceptable dust palliatives is available at: [www.nysdot.gov/divisions/engineering/technical-services/geotechnical-engineering-bureau/dust-palliatives](http://www.nysdot.gov/divisions/engineering/technical-services/geotechnical-engineering-bureau/dust-palliatives) .

For areas not subject to traffic, products and materials may be applied or placed on soil surfaces to prevent airborne migration of soil particles, including:

- Vegetative Cover –provides the most practical method of dust control.
- Mulch (including rolled erosion control products) –provides a fast, effective method of dust control.
- Spray Adhesives –Generally composed of polymers in a liquid or solid form mixed with water to form an emulsion that is sprayed on the soil surface. The mixing ratios and application rates will be in accordance with the manufacturer's recommendations for the specific soils on the site. Adhesives shall not be applied to wet soils or if there is a probability of precipitation within 48 hours.

For areas subject to traffic (traveling public or construction traffic) products and materials may be applied or placed on soil surfaces to prevent airborne migration of soil particles, including:

- Water Sprinkling – The site may be sprayed with water until the surface is wet. This is especially effective on haul roads and access routes.
- Polymer Additives –Polymers shall be mixed with water and applied to the driving surface using mixing ratios and application rates in accordance with the manufacturer's recommendations. No application of the polymer will be made if there is a probability of precipitation within 48 hours of its proposed use. Any polymers must be used in accordance with the NYSDEC issued "Conditions for Use" and "Application Instructions." This information can be obtained from the NYSDEC website.
- Barriers – Woven geotextiles or stone can be placed on the driving surface to effectively reduce dust throw and particle migration on haul roads.
- Windbreak – A silt fence or similar barrier can control air currents at horizontal intervals equal to ten times the barrier height. Preserve existing vegetation that acts as a wind barrier as much as practical.
- Wheel Washing – Mechanical or manual wet-method cleaning of on-road construction vehicle tires prior to leaving site.

**D262100**  
**SPECIAL NOTE**

**Diesel Emission Reduction Act (DERA) Regulatory Compliance**

All Department Contractors and Subcontractors are made aware that Environmental Conservation Law (ECL) 19-0323 and New York State Department of Environmental Conservation (NYSDEC) regulation 6 NYCRR Part 248 *Use of Ultra Low Sulfur Diesel (ULSD) Fuel and Best Available Retrofit Technology (BART) for Heavy Duty Vehicles* requires 100% compliance beginning in 2010 for regulated heavy duty diesel vehicles working on all State awarded contracts. DERA is a requirement of ECL, not a contractual requirement of NYSDOT. NYSDEC is responsible for regulatory enforcement. NYSDOT is responsible for annual Regulatory Entity reporting.

All Department Contractors and Subcontractors shall make determinations of regulatory applicability for vehicles in inventory used on active Department contracts beginning January 1<sup>st</sup> of every year. These determinations shall be based on the definition of Heavy Duty Vehicle (HDV) including on and off road diesel vehicles having gross vehicle weights in excess of 8,500 pounds, excluding vehicles that are exempt as defined in 6 NYCRR 248-1.1(b)(14). Contractors and Subcontractors shall also quantify ULSD fuel used by regulated vehicles beginning with active contract work January 1<sup>st</sup> of every year.

An electronic copy of 6NYCRR Part 248 can be accessed at [www.dec.ny.gov/regulations/56222.html](http://www.dec.ny.gov/regulations/56222.html). Electronic copies of the Regulated Entity Vehicle Inventory Form and the Regulated Entity and Contractors Annual Report Form can be accessed under Part 248 Use of Ultra Low Sulfur Diesel Fuel and Best Available Retrofit Technology for Heavy Duty Vehicles at the following link: [www.dec.ny.gov/chemical/4754.html](http://www.dec.ny.gov/chemical/4754.html).

DERA annual reporting by Department Contractors and Subcontractors shall be submitted to NYSDOT by April 1<sup>st</sup> of every year (all 2010 information to NYSDOT by April 1, 2011, all 2011 information to NYSDOT by April 1, 2012, etc.). Beginning in 2011 the following numbered 2010 information shall be submitted:

1. Contact information including firm name, contact person, phone number and e-mail
2. Annual total quantity of ULSD fuel used by covered vehicles on NYSDOT contracts
3. Annual fleet information for covered vehicles on NYSDOT contracts as provided in the following table:

-Number of on-road HDVs as defined in 248-1.1(b)(14) of 6NYCRR Part 248
-Number of off-road HDVs as defined in 248-1.1(b)(14) of 6NYCRR Part 248
-Number of bi-fuel HDVs as defined in 248-1.1(b)(3) of NYCRR Part 248
-Number of inventoried HDVs retired from your fleet prior to end of reporting year and not replaced
-Number of Alternative-fuel vehicles as defined in 248-1.1(b)(2) of NYCRR Part 248
-Number of HDVs that have been repowered/replaced with 2007 USEPA Diesel certified engines
-Number of HDVs that have been retrofitted with a USEPA or CARB approved device prior to 2/12/07
-Total number of regulated vehicles subject to BART requirements
-Total number of regulated vehicles with a BART device
-Number of NYSDEC approved waiver HDVs
-Total number of compliant vehicles
-Percentage of fleet meeting BART requirements as per 248-3.1(e) of 6NYCRR Part 248

Electronic mail submissions to [dera@dot.state.ny.us](mailto:dera@dot.state.ny.us).

**D262100**  
**SPECIAL NOTE**  
**ANCHORING MATERIALS - CHEMICAL CURING**

**SPECIAL NOTE**

Due to safety concerns, the use of §701-07 *Anchoring Materials – Chemical Curing*, will not be allowed in any overhead applications or where sustained tensile loads will exist. This requirement includes but is not limited to direct overhead installations such as utilities to undersides of bridge decks and overhead protective screening.

When such work is required, alternative anchoring methods or materials like mechanical anchors or cementitious grouting operations, must be used in these locations. Use of alternate materials or methods not previously approved shall require approval of the Deputy Chief Engineer Structures (DCES).

Further, use of §701-07 *Anchoring Materials – Chemical Curing* will not be allowed in any horizontal or vertical applications where failure would result in risk or injury to the public. Applications where only cementitious grouts shall be required include but are not limited to decorative railings, pedestrian fence, and screening. Bridge railing installations shall only use §701-05 *Concrete Grout Materials* as presently required by specifications. Substitution of §701-07 *Anchoring Materials – Chemical Curing* shall not be allowed for bridge railing installations.

Use of §701-07 *Anchoring Materials – Chemical Curing*, may be allowed for temporary applications, and when specified, shall be designed and stamped by a PE. Temporary items anchored using §701-07 *Anchoring Materials – Chemical Curing* shall be rendered inoperable upon completion of their use on a project.

**SPECIAL NOTE**  
**OPTIONAL USE OF WARM MIX ASPHALT (WMA) TECHNOLOGIES**

The contractor has the option of using an Approved WMA Technology in the production of all 402, *Hot Mix Asphalt (HMA)* items, except *SUPERPAVE HMA with Ice Retardant* items, *Waterproofing Bridge Deck HMA* items, and *Paver-Placed Surface Treatment* items, at no additional cost to the State.

If the contractor chooses to use a WMA technology, the provisions of §401 and §402 shall apply including the following:

Use an approved technology appearing on the Approved List for *Technologies for Warm Mix Asphalt*. Design a mixture using a WMA Technology in accordance with MM 5.16, *Superpave Hot Mix Asphalt Mixture Design and Mixture Verification Procedure*. At a minimum, a one point verification of the mixture's volumetric properties is acceptable for the following situations:

- When the WMA mix design is based on an existing Production Status HMA mix design.
- When the WMA mix design is based on, and utilizes a different WMA technology than, an existing Production Status WMA mix design.

Comply with the latest manufacturer's "Production, Testing, and Compaction Details" from the Approved List for incorporating the WMA technology. Test specimens may be made from plant produced or laboratory prepared WMA. Test specimens must be made from plant produced WMA if adding the WMA technology in the lab does not simulate the production process. The Regional Materials Engineer (RME) may require a State representative be present during the fabrication and testing. Submit the WMA design to the RME for review and verification at least 14 calendar days before production, including:

- Name of WMA technology and the target dosage rate.
- If using an additive other than water,
  - Submit a MSDS for the additive.
  - Submit either enough of the additive for the laboratory mix design verification, or the additive pre-blended in the PG Binder at the correct dosage. If the additive is not pre-blended into the PG Binder, include directions for properly incorporating the additive into the laboratory made mixture.
- Prior to the submission of any mix design, contact the RME to determine if there is an increased concern regarding the mixture's moisture susceptibility based on the WMA technology and/or the type of aggregate being used, or the performance of similar mixes. The RME may require AASHTO T 283 moisture susceptibility test results, meeting a minimum Tensile Strength Ratio (TSR) of 80%, as part of the mix design submission.

Submit Production Quality Control Plan revisions incorporating the WMA technology if not previously submitted.

For 80 Series Compaction Method, complete all breakdown roller passes before the mat temperature falls below 230° F, unless approved by the Director, Materials Bureau.

When the asphalt mixture is being placed over a *Sheet-Applied Waterproofing Membrane*, maintain a minimum delivery temperature in accordance with the Material Detail Sheets prepared by the membrane manufacturer.

## ASPHALT PRICE ADJUSTMENT

ASPHALT PRICE ADJUSTMENT CONVERSION FACTORS		
MATERIAL DESCRIPTION	CONVERSION FACTOR	* ITEM NUMBER
Bituminous Stabilized Course	0.065 t PGB/yd <sup>3</sup>	302.01, .0102
Asphalt Treated Permeable Base Type 1	0.030 t PGB/t	402.010901
Asphalt Treated Permeable Base Type 2	0.035 t PGB/t	402.011901
True and Leveling	See Note 5	402.017901, 402.018901
Shim Course	0.0825 t PGB/t	402.058901
Type 10FX Top	0.055 t PGB/t	402.200401 RR
6.3 SUPERPAVE HMA	0.065 t PGB/t	402.067x01 RR
9.5 SUPERPAVE HMA	0.060 t PGB/t	402.09xx01, 402.09xx01 RR
12.5 SUPERPAVE HMA	0.054 t PGB/t	402.12xx01, 402.12xx01 RR
19 SUPERPAVE HMA	0.047 t PGB/t	402.19xx01
25 SUPERPAVE HMA	0.044 t PGB/t	402.25xx01
37.5 SUPERPAVE HMA	0.039 t PGB/t	402.37xx01
Asphaltic Sealants (ASTM 6690)	0.00272 t PGB/gal	402.75XX RR
Paver Placed Surface Treatment Types A, B and C	0.0013 t PGB/yd <sup>2</sup>	402.918x02 RR, 402.928x02 RR, 402.938x02 RR
Tack Coat (Asphalt Emulsion)	0.0012 t PGB/gal	407.01 RR
Bituminous Material (Pavement, Shoulders)	0.0025 t PGB/gal	410.07
Micro-Surfacing, Type II	0.090 t PGB/t	410.102102 RR
Micro-Surfacing, Type III and Rut Filling	0.075 t PGB/t	410.103102 RR, .104102 RR
Quick-Set Slurry, Type II	0.115 t PGB/t	410.202302 RR
Quick-Set Slurry, Type III	0.100 t PGB/t	410.203302 RR
Asphalt Sidewalks, Driveways	See Note 5	608.02xx RR
Miscellaneous Asphalt 702-07	0.0040t PGB/gal	618.07
Asphalt Emulsion 702-3001	0.0021t PGB/gal	618.3001, 407.02 RR
Asphalt Emulsion 702-3101, 702-3102	0.0024t PGB/gal	618.3101, 618.3102
Asphalt Emulsion 702-3201, 702-3301, 702-3401, 702-3402	0.0025t PGB/gal	618.3201, 618.3301, 618.3401, 618.3402
Asphalt Emulsion 702-3501, 702-3601	0.0022t PGB/gal	618.3501, 618.3601
Cationic Asphalt Emulsion 702-4001	0.0023t PGB/gal	618.4001, 407.02 RR



ASPHALT PRICE ADJUSTMENT

Cationic Asphalt Emulsion 702-4101, 702-4201, 702-4301	0.0025 t PGB/gal	618.4101, 618.4201, 618.4301
Cationic Asphalt Emulsion 702-4401, 702-4501	0.0022 t PGB/gal	618.4401, 618.4501

**Notes:**

1. In accordance with Standard Specification §698-3.01, the index value for the asphalt price adjustment is the average posted price of Performance Graded Binder (PGB) for the month of bid letting.
2. A two digit suffix (RR) at the end of a contract pay item indicates a special specification.
3. Quality Adjustment Items (402/608) are not eligible for fuel or asphalt price adjustment.
4. The conversion factors for HMA mixed with slag shall be increased by 25%.
5. The conversion factor for True & Leveling, Driveways, or other items that allow mix options will be based on the actual mixtures used.

\* Item Number: This is the contract pay item number under which these materials are most frequently paid. Unless indicated otherwise, materials similar to those indicated under the column entitled "Material Description" are also eligible for adjustment using the factor listed for a similar material with the same pay units regardless of the actual contract pay item number. Contact the Regional Materials Engineer with any questions regarding applicability of contract pay items that are not listed.

## FUEL PRICE ADJUSTMENT

FUEL PRICE ADJUSTMENT USAGE FACTORS		
MATERIAL DESCRIPTION	USAGE FACTOR	* ITEM NUMBER
Excavation & Embankment	0.45 gal/yd <sup>3</sup>	203.05, 203.06, 203.07, 203.08, 203.20, 203.21 and 203.25
Excavation	0.35 gal/yd <sup>3</sup>	203.02
Embankment	0.10 gal/yd <sup>3</sup>	203.03
Controlled Low Strength Material	1.00 gal/yd <sup>3</sup>	204.01, 204.02
Structure/Trench/Culvert Excavation	0.50 gal/yd <sup>3</sup>	206.01, 206.02, and 206.04
Bituminous Stabilized Course	1.40 gal/yd <sup>3</sup>	302.01
Subbase Course	1.00 gal/yd <sup>3</sup>	All 304 Items
Hot Mix Asphalt	2.50 gal/ton	402 Items and 608.02xx RR
Production Cold Milling	0.10 gal/yd <sup>2</sup>	All 490 Items
Portland Cement Concrete Pavement	1.00 gal/yd <sup>3</sup>	502 Items
Footing Concrete & Concrete for Structures - All classes(A, F, G, HP, etc.)	1.00 gal/yd <sup>3</sup>	555.xx
Approach Slabs and Structural Slabs with bottom formwork	0.25 gal/yd <sup>2</sup>	557.xx
Structural Slabs - no bottom formwork	0.15 gal/yd <sup>2</sup>	557.xx
Class D Concrete	0.05 gal/yd <sup>2</sup>	557.13
Topsoil	0.10 gal/yd <sup>3</sup>	613.02, 613.03

**Notes:**

1. In accordance with Standard Specification §698-3.02, the index value for the fuel price adjustment is the average posted price for the month of bid letting.

2. Quality Adjustment Items (402/502/608) are not eligible for fuel price adjustment.

\* Item Number: This is the contract pay item number under which these materials are most frequently paid. Unless indicated otherwise, materials similar to those indicated under the column entitled "Material Description" are also eligible for adjustment using the factor listed for a similar material with the same pay units regardless of the actual contract pay item number. Contact the Regional Materials Engineer with any questions regarding applicability of contract pay items that are not listed.

**SPECIAL NOTES****EXISTING VEGETATION:**

The contractor shall give particular attention and care to protect from damage all existing vegetation, including turf, trees, ornamental plantings, etc., which is not within the actual construction limits. Every attempt shall be made to protect and save the vegetation that is near the construction limits according to the instructions of the Engineer.

**EXISTING ROADS:**

Existing roads used for the hauling of materials or equipment shall be kept free from debris and maintained by the contractor and left in a condition satisfactory to the engineer. The contractor is warned that he shall be held responsible for any damage to existing roads caused by the operation of his equipment, and that adequate repair for such damage shall be required at his expense.

**PERMITS:**

The contractor shall give all necessary notices, obtain all permits and pay all legal fees encountered in the work. He shall also comply with all public agency laws, ordinances or regulations of the State of New York and local agencies having jurisdiction over work of this character. Where a conflict occurs, they shall take precedence over any requirements of these specifications. This, however, shall not be interpreted as permitting the use of materials, equipment or work procedures inferior to those specified.

**EMERGENCY REPAIRS:**

The contractor shall provide the local police, in writing, the name, address and telephone number of a person or persons authorized outside of normal contract working hours to secure and use labor, material and equipment for emergency repairs to make safe the entire area of the contract. Duplicate copies of such notices shall be filed with the Engineer and the Regional Director.

**INSURANCE COVERAGE:**

The contractor's attention is directed to the fact that the construction signs are outside the contract limits and that proper insurance coverage should be provided for this work.

**CTDOT "STATE LIABILITY" CONSTRUCTION SIGNS**

CTDOT will provide the "State Liability" constructions signal or signals to be installed in the State Connecticut section. The Contractor shall contact CTDOT at the beginning of construction and request the sign(s) and location for installation.

Contact information:

Philip Cohen

Traffic CTDOT  
860.594.2744  
[Philip.cohen@ct.gov](mailto:Philip.cohen@ct.gov)

**VIEWING PLATFORM:**

The contractor shall provide a viewing platform with the dimensions shown on the contract plans. Final location and elevation of the viewing platform shall be approved prior to final design. The platform shall be installed prior to the I-84 eastbound bridge slide in. The Contractor shall submit the design, including computations and method of installation to the Engineer-In-Charge for approval. The design shall be performed and sealed by a Professional Engineer, licensed and registered to practice in New York State.

**OTHER CONTRACTORS:**

The contractor's attention is directed to the fact that because of work on other contracts within the limits of this contract, he may not have exclusive occupancy of the territory within the limits of this contract. The provisions of Subsection 102-09 of the Standard Specifications shall apply.

**SHOP DRAWING APPROVAL:**

All shop, erection, demolition, temporary structure, procedural and other drawings shall be submitted to the Engineer-In-Charge for distribution to the appropriate approval office. This includes drawings from fabrications and precasters. The contractor may submit shop drawings for review prior to the award.

**PRECAUTIONARY MEASURES:**

At the end of each day's work and at all other times when construction operations are suspended, all equipment and other obstructions shall be removed from that portion of the roadway normally open for traffic.

Upon the completion of the work at each location, the contractor shall remove all remaining material and equipment and shall leave the area which may have been affected by this operation in a neat condition. All excavated material shall be taken away from the site at the end of each working day to a location approved by the Engineer.

**USE OF SHEETING BOX:**

Although the use of the sheeting box will not necessarily be prohibited, the contractor's methods of excavating and sheeting trenches shall be reviewed and approved by the Engineer prior to the commencement of work in any area.

The contractor is to be fully cognizant of the fact that when excavating trenches adjacent to pavements which are to remain, he will be held fully responsible for any undermining, settlement or other damage to the existing pavement.

In the event that any such undermining, settlement or damage does occur, the contractor shall take immediate corrective action as directed by the Engineer which may result in the removal and replacement of the pavement at the contractor's expense.

**LONGITUDINAL PAVING JOINT REQUIREMENTS:**

Prior to paving operations on this contract the contractor may request approval, in writing, to leave exposed a longitudinal pavement joint in excess of 100 feet at the end of the working day. Approval is contingent upon the use of Option B - Tapered Wedge Joint of Section 401-3.13 Joints, of the Standard Specifications. Maintenance and protection of traffic requirements to provide adequate, advanced warning to motorists must be provided as detailed in these contract documents. As a minimum W8-39, 'UNEVEN LANES' signs must be posted on both sides of the roadway at a maximum 1000 foot spacing. Paving operations must be planned so the edge is only exposed to traffic for one night and is not exposed over weekends or holidays.

**CONSTRUCTION, EXCAVATION AND DEMOLITION OPERATIONS AT OR NEAR UNDERGROUND FACILITIES:**

The contractor is hereby put on notice that the provisions of New York State Industrial Code 753 (effective February 5, 1997) apply to this project and no direct payment for any work required by the code will be made.

**EXISTING DRAINAGE, WATER AND SEWER FACILITIES:**

Existing drainage structures to be removed or abandoned, shall be broken up to a depth of at least 4 feet below finished surface and filled with thoroughly compacted material as directed by the Engineer. The bottom slab or paved inverts of structures to be removed or abandoned shall be broken up in such a manner so as to prevent any water from being trapped. All castings from such structures shall become the property of the contractor and shall be removed from the work site, except where removing and resetting castings or removing and storing castings are specifically called for, or unless otherwise directed by the Engineer.

The ends of all pipes to be abandoned and left in place shall be plugged with Class A concrete.

Drainage, water or sewer pipes that are to remain in service and that are now connected to existing pipe lines that are to be removed or abandoned, shall be reconnected to new or existing pipe lines or structures.

When any work being done under this contract intercepts or affects any existing drainage, water or sewer pipe or appurtenance that is in use, whether shown on the plans or not, the contractor, when directed by the Engineer, shall relocate, extend, reconnect, alter or repair it as necessary to keep it in proper working order. The cost of furnishing all labor, materials and equipment necessary to satisfactorily complete the work will be paid for under the appropriate pay items. If the intercepted or affected drainage, water or sewer pipe or appurtenance is no longer in use, it shall be removed, broken up, disconnected, capped or plugged as ordered by the Engineer.

**DRAINAGE STRUCTURES:**

1. Item 203.07 Select Granular Fill will not be required for backfill around drainage structures. Backfill with suitable material under the requirements of Item 206.XX.
2. All drainage structures with top slabs, installed at the edge of pavement shall be placed so the wider slab section is opposite the paved traveled way. Standard Sheet 604-2 for Rectangular Drainage Structure Type "A" thru "P" shown with manhole frame and cover illustrates the proper orientation. Manhole steps when required will have to be installed on a wall opposite the wide slab.

**UTILITY QUALITY LEVEL DESCRIPTIONS:**

The quality level (i.e., QLA, QLB, etc.) for each utility shown on the general plans and utility plans are as shown:

Quality Level A - The highest degree of accuracy; the utility information on the contract plans have been field located and verified by excavation, when appropriate. (Shown as QLA).

Quality Level B - Subsurface geophysical locating techniques (i.e., underground cameras, radar, sonar, tone outs, etc.) and existing record plans have been used to locate utilities. No excavations were performed. (Shown as QLB).

Quality Level C - Record information provided by utility owners was plotted on the contract plans. Depths were not field verified. Physical surface features like manholes, valve boxes and hydrants have been field located. (Shown as QLC).

Quality Level D - Existing NYSDOT and utility company records were used to locate subsurface utilities. (Shown as QLD).

**REPORTING OF SPILLS, DISCHARGES AND/OR CONTAMINATED SOILS:**

The contractor shall be responsible for reporting any findings of spills, leaks of petroleum products, contaminated soils, buried drums of unknown substances, or any other potentially hazardous materials to the New York State Department of Environmental Conservation (NYSDEC) within two (2) hours of the discovery. Notification must be made by calling NYSDEC Spills hotline number - (800) 457-7362.

**PG BINDER AND MIX DESIGN LEVEL:**

PG BINDER AND MIX DESIGN LEVEL:

Requirements of this note apply to all Section 402 Hot Mix Asphalt (HMA) items in this contract.

**PG BINDER**

Use a PG 70-22 meeting the requirements of AASHTO M320, Standard Specification for Performance

Graded Asphalt Binder for the production of HMA mixtures for this project.

Use of polyphosphoric acid (PPA) to modify the PG binder properties is prohibited. This prohibition also applies to the use of PPA as a cross-linking agent for polymer modification.

**MIX DESIGN**

The mixture designs must be developed in accordance with the criteria specified in the HMA items that are appropriate for an “Estimated Traffic” level of “> 30.0 Million 18 kip ESALs

**STONE FILLING ITEMS 620.XX:**

The color of the stone filling for these items used for permanent installations shall be a medium to dark brown, dark blue or dark gray. White or light colored stone will not be accepted.

**STORMWATER POLLUTION PREVENTION PLAN (SWPPP)  
MADE PURSUANT TO THE STATE POLLUTANT DISCHARGE ELIMINATION  
SYSTEM  
(SPDES) STORMWATER GENERAL PERMIT FOR STORMWATER DISCHARGES  
FROM CONSTRUCTION ACTIVITY  
(Permit No. GP-0-10-001)**

PIN: 8062.10

Project Name: Bridge Replacements Carrying I-84 over Dingle Ridge Rd.

Project Description: This project proposes to replace the twin bridges which carry Route I-84 over Dingle Ridge Road in Putnam County.

A Stormwater Pollution Prevention Plan (SWPPP) has been prepared for this project, and is included on the “Supplemental Information Available to Bidders” form (CONR 9k). The following plan sheets, specifications, state and federal permits/approvals, and additional information are components of the Stormwater Pollution Prevention Plan (*list*):

Plans: ECN-1, ED-1, ECP-1 thru ECP-7

Specifications: Item 203.02 and 203.03  
Item 207.22

209 items  
 Item 603.98100402  
 Item 605.0901 and 605.1101  
 Item 610.10, 610.1402 and 610.1601  
 Item 620.03

Permits/Approvals: N.Y.S. D.E.C. Stormwater General Permit for Construction Activities  
 (GP-0-10-001)

Additional Information (*check all that apply*):

- x Soils Description
- x Description of Pollution Prevention Measures
- x Description of Temporary & Permanent E&SC & Stormwater Practices
- x Hydrologic/Hydraulic Analyses (including comparison of pre-development vs. post-development runoff conditions)
- x Construction Sequencing Plan
- x Certification Form(s)
- x Operations & Maintenance Requirements
- Other:

**STORMWATER POLLUTION PREVENTION PLAN (SWPPP) (Permit No. GP-0-10-001):**

**Contractors' Obligations under SPDES General Permit GP-0-10-001**

Every Contractor and Subcontractor that performs an activity that disturbs or exposes soil or implements a portion of the Stormwater Pollution Prevention Plan is required, under the terms of the SPDES General Permit GP-0-10-001, to complete and sign the Contractor/Subcontractor SPDES Permit Certification (Form CONR 5). Contractors are responsible for securing applicable Subcontractor signatures and should consider obtaining certifications as part of the Subcontractor approval process.

**CONR 5** is available in electronic format from the NYSDOT Construction Division website at <https://www.nysdot.gov/portal/page/portal/main/business-center/contractors/construction-division/forms-manuals-computer-applications-general-information/environmental>

The Contractor shall provide a signed certification for itself at the Preconstruction Meeting. The Contractor will not be allowed to begin work until the certification has been submitted to the Engineer. All subcontractors shall submit a signed copy of the CONR 5 with the subcontractor approval package. Subcontractors will not be approved without a signed certification.

**ITEM 610.0203 ESTABLISHING TURF:**

**Seed Mix C – Establishing Turf for General Use and Slopes  
 610-2.02 C Seeds 713-04**



Detail Specifications for Seeds

Seed Mix C1:

Name	Variety	% Of Mixture
Seed Mix: C1 To Be Applied @ 24 lbs of <b>Pure Live Seed</b> per Acre		
Chewing Fescue/ <i>Festuca rubra</i>	Boreal	30
Tall Fescue/ <i>Festuca arundinacea</i>	Greystone	30
Kentucky Bluegrass / <i>Poa pratensis</i>	Bluegrass	20
White Clover / <i>Trifolium repens</i>	White Clover	20

Seed Mix C2:

Name	Variety	% Of Mixture
Seed Mix: C2 To Be Applied @ 24 lbs of <b>Pure Live Seed</b> per Acre		
Perennial Ryegrass / <i>Lolium perenne</i>	Commercial	100

**Notes**

Seed Mix C1 & C2 shall arrive on the job in separate bags with appropriate labels. Prior to application, seed mixes shall be proportionally combined by contractor to achieve desired seeding quantities through one application.

**STABILIZED CONSTRUCTION ENTRANCE**

A quantity for Stabilized Construction Entrances (Item 209.22) is included in this contract and are shown on plans. The locations shall be verified in the field by the Engineer-in-Charge in consultation with the Construction Environmental Coordinator and the contractor.

**CHANNELIZING DEVICE SPACING REDUCTION:**

Channelizing devices are used to provide a physical separation between the travel space and the work space and buffer spaces. Recommended practices for channelizing devices are provided in the MUTCD and Section 619-3.02 J.

Drums or vertical panels are preferred for long-duration work zones, and at any locations where the risk of intrusion is high, AOB. Traffic cones, 36" high with reflective stripes, are normally adequate for work zones set up and removed on a daily basis.

Frequent checks by the contractor shall be made to reset channelizing devices dislodged by traffic.

For paving operations on 2-lane, 2-way roadways, longer device spacing may be used where a pilot vehicle is used.

### **COORDINATION WITH UTILITIES**

All known public and private utility lines within or adjacent to the site of the work, are shown in their existing approximate locations on the contract plans. The contractor is cautioned that these locations are not guaranteed; nor is there a guarantee that all such lines in existence have been shown on the plans.

The contractor shall conduct his operations as to prevent damage to such facilities. He shall make such explorations as may be necessary to determine the dimensions and locations of lines that may be subject to damage. Notification to the various owners of facilities shall be given in accordance with New York State Industrial Code 753 (effective February 5, 1997).

The contractor shall satisfy himself as to the exact location of utility lines and shall protect and support in a suitable manner at his own expense all underground utilities encountered in his excavating and trenching operations. The contractor shall make good any damage and consequential damages to those utilities caused by his operations. If the nature of the damage is such as to endanger the satisfactory operations of the utilities and the necessary repairs are not immediately made by the contractor, the work may be done by the respective owning companies and the cost thereof charged against the contractor.

Prior to the commencement of construction, the contractor shall meet with all the known public and private utility companies occupying the work site. The contractor shall, at this meeting, inform the utility companies of his schedule of operations and so coordinate his work with these companies.

The contractor specifically agrees that he has included in his unit prices and lump sum prices bid for the various items of the contract any additional cost of doing the work under this contract because of the fact that he may not have a clear site for the work and because of interference of roadway use by the utilities, and the necessity or desirability of opening certain sections of pavement to traffic before the entire work is completed.

The following privately owned public utility companies will impact the State contractor's construction time schedule for PIN 8062.10.101, Interstate 84 over Dingle Ridge Road, Town of Southeast, Putnam County.

- **New York State Electric and Gas Corporation**

Contacts: Mr. Craig Lincoln at (845)278-8120, ext. 368.

There is one ( 1 ) utility pole with electric facilities in conflict with the proposed construction of the east abutment of the new I-84 eastbound bridge. New York State Electric and Gas (NYSEG) will be responsible for setting a new pole outside of the construction area and for re-establishing the underground facilities to the new pole. The new pole will be set to the south (up the hill) of the existing pole closer to the Dingle Ridge Road/Tulip Road intersection. NYSEG's intent is to relocate the pole and re-

establishing electric service prior to the State's construction. If however, the work is not completed by the time the project is awarded, NYSEG forces will require three ( 3 ) weeks to complete this work once the pole stake-out has been approved and agreed upon by the State's engineer-in-charge, the State contractor and NYSEG.

According to NYSEG, their underground facilities run from the riser on the pole previously discussed, under the existing paved, east shoulder of Dingle Ridge Road. Being under the shoulder, it is anticipated that the facilities will not be in conflict with the construction of the new abutments. If the facilities are exposed during the construction of the abutments, NYSEG will protect and support their facilities using their own forces.

- **American Telephone and Telegraph, Inc. (AT&T)**

Contact: Mr. Gerald Lynn Utility Services at (845)463-2733.

AT&T has an underground cable between the existing piers on the west side of Dingle Ridge Road and the existing guide rail. It is anticipated that while the facilities may be exposed during the construction of the new bridge abutments, it will not be in physical conflict. It has also been confirmed by AT&T that this cable is no longer in use. Regardless, AT&T should still be consulted during construction and if the cable is exposed during the construction of the abutments, AT&T will protect and support it using their own forces.

- **Comcast Cable** – Contact: Mr. Robert Quigg at (845)531-3960
- **Verizon Communications** – Contacts: Mr. Carl Sartori at (914)741-8365 and Mr. Jonathan Morris at (914)741-8866

Comcast Cable and Verizon Communications each have an underground cable running along Dingle Ridge Road approximately one ( 1 ) to two ( 2 ) feet off of the west edge of the asphalt. Their cables rise on the existing utility poles on each side of the Interstate overpasses. The utility pole on the north side of highway will be in conflict with construction and must be removed. It is both utility companies intention to eliminate the pole in conflict extending their underground cables to utility poles to the north. It is both companies intention to vacate the pole and to extend the underground facility prior to the State's construction. If however, the work is not completed by the time the project is awarded, each company will require three ( 3 ) weeks to complete their work. It is anticipated that while the facilities may be exposed during the construction of drainage and/or the new bridge abutments, they will not be in physical conflict. If the facilities are exposed during the construction of the abutments, the companies will protect and support their facilities using their own forces.

If for some unseen reason the underground cables are in conflict and must be cut into for the State to progress the project, each company will require six ( 6 ) weeks to relocate their facilities.

END OF SPECIAL NOTES

**SPECIAL NOTE  
DESCRIPTION OF I/D PORTION WORK  
PIN 8062.10**

The Department has determined that the early completion of a specific stage of the contract work requiring closure of Interstate I-84, eastbound on one weekend and westbound on another, would benefit both the traveling public and the Department. Therefore, the Contractor shall be awarded incentive payments for early completion of each of the bridges carrying Interstate 84 over Dingle Ridge Road according to the terms of this special note.

The eastbound bridge shall be constructed the first weekend and the westbound bridge on a subsequent weekend as described in the contract plans. Similarly, late completion of the bridges opening to traffic will result in a disincentive assessment which will be deducted from payments due the contractor. Payments and/or assessments will be made under Item 698.9394—01 - INCENTIVE PAYMENTS / DISINCENTIVE ASSESSMENTS / HOURLY BASIS.”

This note is a supplement to the special note titled “INCENTIVE / DISINCENTIVE CLAUSE / HOURLY BASIS.” See this title for Definition of Terms that apply.

Incentive/Disincentive portions of the work shall include all work required to construct each of the new bridges and highway approaches required to safely open them to traffic. The major bridge work includes demolition of existing bridge and the sliding of the new superstructure on the new foundation. The major highway approach work elements include pavement construction required to raise I-84 to meet the new east and west bound bridges as well as interim pavement striping and installation of protection barriers.

The Contractor is alerted to the fact that this work will necessitate simultaneous construction activities and/or multiple construction shifts.

The contractor shall notify the Engineer in Charge (E.I.C.) in writing 21 calendar days in advance of any proposed closure of the interstate.

After opening the bridge to traffic, the contractor may perform items of work including, but is not limited to, the following:

1. Placement of permanent highway guide rail.
2. Placement of top course of asphalt concrete
3. Placement of final pavement stripes

The Incentive/Disincentive clause is specifically intended to minimize the length of time that the interstate I-84 is closed to traffic. Temporary measures that further the intent of this clause shall be permitted at the Engineer-in-Charge’s discretion at no additional cost to the State. In all cases where doubts exist as to the necessity of work items, the

**SPECIAL NOTE  
DESCRIPTION OF I/D PORTION WORK  
PIN 8062.10**

Project Engineer-in-Charge shall be the final arbiter of which items of work are required to be completed before the bridge is opened.

Event for determining the number of consecutive hours for the performance of the I/D work:

The exact calendar date shall be Saturday September 7, 2013. The detour must abide by the lane closure restrictions noted elsewhere in the plans and it shall begin Saturday, September 7, 2013 at 17:00 hours. The counting of consecutive hours for the I/D portion work will begin when the detours are in place, Dingle Ridge Road traffic removed from the intersection, and interstate traffic is on the detour.

Ending date or event for determining the number of consecutive hours for the performance of the I/D portion work:

The counting of consecutive hours for the I/D portion work will end when the above tasks are completed to the satisfaction of the Engineer, the off-site detour signage is removed and the road is opened to traffic.

Data for Bid Preparation

The maximum number of consecutive hours for the performance of I/D work shall be **18 (eighteen) hours.**

The hourly cost for incentive/disincentive shall be **\$10,000 (Ten Thousand Dollars) per hour.**

Maximum number of hours for incentive payment is: **3 (Three) hours.**

The \$10,000 (Ten Thousand Dollars) disincentive assessment will apply on the nineteenth (19<sup>th</sup>) hour that lane restrictions are in place, and every hour, or portion of an hour, thereafter in which the work is incomplete.

Conditions Applicable During Performance of the I/D portion work:

All I/D portion work shall be completed by 11:00 hours on Sunday, September 8, 2013 following the commencement of I/D work. If the I/D portion work is not completed by this time, the disincentive assessment period will begin the following hour. If the I/D portion work is completed after this time, the contractor will not be eligible for any incentive payments, regardless of the total number of consecutive hours required to complete the I/D portion work. ”

END OF SPECIAL NOTES

**SPECIAL NOTE  
INCENTIVE/DISINCENTIVE CLAUSE / HOURLY BASIS**

**A. GENERAL.**

The contractor will be awarded incentive payments for early completion of I/D work as described in this special note. Late completion of I/D work will result in a disincentive assessment which will be deducted from money due to the contractor. Payments and/or assessments will be made in accordance with item 698.9394 01 INCENTIVE PAYMENTS/DISINCENTIVE ASSESSMENTS / HOURLY BASIS."

The I/D work and incentive payments/disincentive assessments are described in the special note "DESCRIPTION OF I/D PORTION WORK." If there are multiple I/D work time periods, each time period will include its own:

- maximum total number of hours to perform the work;
- starting and ending times or events for the I/D period;
- hourly cost;
- maximum number of hours for incentive determination; and
- time frames and critical dates, if applicable.

**B. DEFINITION OF TERMS.**

For this project, the following additional definitions shall apply:

1. Hour - Any continuous 60-minute period beginning at the time when a lane and/or shoulder is closed or obstructed by the Contractor's operation or at the time(s) specified for each I/D period.
2. Hourly Cost - The amount which represents the average hourly cost of interference and inconvenience to the highway and/or bridge user.
3. Engineering Inspection Costs - The costs to the Department for inspection of the contractor's work.
4. Substantially complete - **THIS DEFINITION SHALL APPLY TO ONLY I/D WORK.** Each individual I/D work period shall be considered to be substantially complete when: 1) all work requiring lane or shoulder closures or obstruction to normal flow of traffic is completed; 2) traffic is following the lane arrangement as shown on the plans for the finished roadway (or the specified phase(s) of work); and 3) all pavement construction, resurfacing, and traffic control devices shall be in their final position or as called for in the plans for the specified work.

C. **EARLY COMPLETION OF I/D WORK**

The Contractor will be paid the hourly cost specified for each I/D work period for each hour the work is substantially completed before the number of hours stated by the Department for that period. The total number of hours for incentive payment for each I/D period shall not exceed the maximum number of hours specified for incentive calculation in the special note "DESCRIPTION OF I/D WORK."

Incentive payments shall be made for each individual I/D work period upon completion of the work included in the particular I/D period. Incentive payments will be made under Item 698.9394 01.

The Engineer shall be the sole authority in determining when the work is substantially complete.

D. **FAILURE TO SUBSTANTIALLY COMPLETE THE I/D WORK IN THE TIME SPECIFIED**

Failure to substantially complete any I/D work within the number of consecutive hours specified will result in the hourly cost specified for that work in the special note "DESCRIPTION OF I/D WORK" being assessed for every hour in excess of the number of consecutive hours specified, up to the time when the work is substantially complete. **THERE IS NO LIMIT ON THE AMOUNT OF DISINCENTIVE ASSESSMENT.**

The assessments for failure to substantially complete the I/D work will be made separately for each I/D work period upon reaching the completion date established for each I/D work period. Disincentive will be collected under item 698.9394 01.

The Engineer shall be the sole authority in determining when the work is substantially complete.

E. **ADJUSTMENTS TO I/D WORK**

Adjustments to the I/D time periods will be made based on the critical path method schedule submitted by the contractor in accordance with scheduling provisions found elsewhere in the contract documents. Delays due to extenuating circumstances beyond the control of the Contractor, as provided in section §108-03, will be considered when making time related adjustments. Adjustments will be separately made for each phase/stage of work subject to I/D provisions.

END OF SPECIAL NOTES

**SPECIAL NOTE**  
**CRITICAL PATH METHOD (CPM) ABC SCHEDULE REQUIREMENTS**  
**PIN 8062.10**

Scheduling is critical to the successful execution of the bridge move and demolition within the ABC Window, as defined in the Special Note "Description of I/D Work." In addition to the attributes of the Progress Schedule provisions as set forth in §108-01, the Contractor shall prepare and submitting an ABC Schedule which demonstrates complete fulfillment of all work during the ABC Window. Schedule shall include all activities which are to occur within the ABC Window and shall be developed in 15-minute increments. In developing the schedule, the Contractor's attention is drawn to the time restrictions set forth in the Special Note "Description of I/D Work."

The purpose of the ABC Schedule shall be to ensure adequate planning and staffing during execution of the work by the parties to the contract. In scheduling and executing the work, the Contractor shall sequence the work commensurate with the Contractor's abilities, resources and the contract documents. The scheduling of activities is the responsibility of the Contractor. Failure by the Contractor to include any element of work required by the Contract in the accepted ABC Schedule does not relieve the Contractor from its responsibility to perform such work. Errors or omissions on schedules shall not relieve the Contractor from finishing all work within the time limit specified for completion of ABC activities.

The Contractor shall submit the ABC Schedule within 45 State business days of receipt of Notice of Award for the Engineer's review and acceptance. The Engineer will review the schedule and return it within 15 State business days of receipt of the Contractor's submission. The Contractor shall address any comments and revise the schedule as necessary. The Contractor shall complete the ABC Schedule and obtain the acceptance of the Engineer within 90 days from Notice of Award and no later than 90 days prior to the start of the ABC period. No work on activities within the ABC Window will be permitted to start until the ABC Schedule has been submitted to the Engineer, and the Engineer determines there are no deficiencies.

Once the ABC Schedule has been accepted, the Contractor shall not deviate from it without first notifying the Engineer in writing and obtaining written approval. Upon receipt from the Contractor of the corrected schedule, a new review period by the Engineer of five (5) State Business days will begin. The Contractor will not be permitted to make any revisions to the schedule within ten (10) State business days of the commencement of the ABC period.

The Contractor shall submit the As-Built ABC Schedule with Actual Start and Actual Finish periods for all activities following the completion.

The Engineer, by accepting the Schedule, does not agree that the ABC Schedule is reasonable or that by following the ABC Schedule the Contractor can complete the work in a timely manner. If, after an ABC Schedule has been accepted by the Engineer, either the Contractor or the Engineer discovers that any aspect of the Schedule is on error, or something significant has been omitted, the Contractor shall correct the ABC Schedule and resubmit the Schedule to the



Engineer for approval.

Acceptance of ABC Schedules by the Engineer shall not be construed to imply approval of any particular construction methods or sequence of construction or to relieve the Contractor from its responsibility to provide sufficient materials, equipment and labor to guarantee the completion of the ABC activities in accordance with the contract documents.

Acceptance of the ABC Schedule by the Engineer does not attest to the validity of assumptions, activities, relationships, sequences, resource allocations, or any other aspect of the schedule. Within the contractual constraints, the Contractor is solely responsible for the planning and execution of the work.

It is not intended that the Engineer, by accepting the schedule should use the Contractor's resource data for anything other than determining the reasonableness of achieving the Contractor's production rates. Resources included with the accepted CPM schedule shall not be misconstrued as a cost benchmark for the performance of planned or actual work.

The cost of all labor, material, equipment, and incidentals required to complete the ABC Schedule shall be included in the unit price bid for Item 585.35010008, "Horizontal Slide and Temporary Shoring."

END OF SPECIAL NOTES

**SPECIAL NOTE  
CRITICAL PATH METHOD (CPM) PROGRESS SCHEDULE REQUIREMENTS  
I/D PROVISIONS  
PIN 8062.10**

Because this project includes the potential for significant incentive/disincentive payments, the timely establishment and maintenance of a CPM Progress Schedule is a priority.

The Contractor should carefully review the requirements of Item 639.10220001 – CPM (Critical Path Method) Progress Schedule – Type 2 and the special notes in the proposal pertaining to the project CPM Schedule. The Special Note, Changes to the CPM Schedule Requirements, identifies several revisions to the allowable time frames included in the specification. These changes were made to provide for the establishment of an acceptable baseline schedule **before** the construction of the new bridge begins.

**Failure to establish and acceptable Final Baseline Progress Schedule @ Award under the provisions of Item 639.10220001 and the various special notes pertaining to the CPM Schedule will not be considered as justification for an adjustment to the time frames pertaining to I/D clauses.**

Particular attention should be given to the specified time frames for the establishment of a Final Baseline Progress Schedule at Award. The Contractor is advised to consider the early submission of a Baseline Progress Schedule as provided for in the specification's Construction Details (Section B. Scheduling Software). This will enable the Department to complete an early review of the Contractor's proposed schedule and facilitate a more productive Preconstruction Schedule Meeting.

**SPECIAL NOTE (1/08/2010)**  
**REVISIONS TO STANDARD SPECIFICATIONS SECTION 100**  
**FOR CPM SCHEDULING**

**A. Types of delay.**

Delay provisions contained in §108-04 of the Standard Specifications are broken down into two categories, Compensable Delay is defined in §108-04.A, and Non-Compensable Delay is defined in §108-04.B.

For purposes of determining when a Request for Extension of Completion Date shall be granted with/without Engineering Charges, delays shall be broken down into either Inexcusable Delays or Excusable Delays. See also §108-03.A **Engineering Charges**.

1. **Inexcusable Delay** - An inexcusable delay is where work has been unduly delayed by the Contractor because of unwarranted reasons, inefficient operation, or for any other reason for which the Department determines the Contractor to be responsible; or delays caused by an event that the Contractor could have foreseen and prevented the delay but failed to do so.
2. **Excusable Delay** - An excusable delay is one caused by an unforeseeable event beyond the Contractor's control. These are limited to those outlined in §108-03.A.1 through 13.

Only delays to work activities on the Critical Path (Critical Delays) may be considered by the Department as a basis for an extension of the Completion Date, with or without Engineering Charges. Delays, regardless of cause, that do not impact the critical path (Non-Critical Delays) shall not be a basis for an extension of the Completion Date.

**B. Written Notice and delay documentation.**

1. The Contractor, upon determining activities on the critical path have been delayed, shall provide written notice to the Engineer within ten work days of the delay causing event. The Contractor shall provide detailed information including:
  - a) The events that caused the delay.
  - b) Party(s) responsible for the delay.
  - c) Activities in the current construction progress schedule affected by the events.
  - d) The magnitude of the delay using the current progress schedule update.
  - e) A time extension request, for any excusable delay.
2. The Engineer will review the delay documentation and the next Monthly Progress Schedule submission, and within 10 State Business days of those submittals will provide a written response to the Contractor. If the Engineer determines the delay is compensable or excusable, added compensation or a time extension as appropriate will be granted under the terms of the contract.
3. If the Engineer disagrees with the delay documentation and/or progress schedule update, a clear explanation will be included in the letter to the Contractor. This letter serves as formal rejection of the delay dispute by the Engineer. If the Contractor does not agree they may follow the Dispute Process (§105-14 **DISPUTED WORK AND DISPUTE RESOLUTION**).

**SPECIAL NOTE (1/08/2010)**  
**REVISIONS TO STANDARD SPECIFICATIONS SECTION 100**  
**FOR CPM SCHEDULING**

4. Once a delay causing event is identified, the responsible party shall take all reasonable steps needed to minimize the impact of the delay. Failure of the Contractor to do so may result in the rejection of all or part of the delay dispute.

**C. Failure to submit progress schedule**

In the event that the Contractor fails to submit the contemporaneous monthly progress schedule update(s), the Contractor waives its rights to contractual adjustments of time and related compensation for delays that accrue during the period in which progress schedules have not been submitted in an acceptable format. Additionally, the Department will have no liability for any subsequent Contractor dispute(s) or claim(s) which occurred during the period of time in which the Contractor failed to submit monthly progress schedule updates(s) timely.

**D. Documentation of Delay**

For any time related dispute damages to be recoverable by the Contractor, the Contractor shall meet the CPM Scheduling specification requirements for a Time Impact Analysis (TIA) and provide contemporaneous records of delays by the Department that adversely affected the Contractors operations within the regular Monthly Progress Schedule submission following the date on which actions resulting in the dispute occurred or conditions resulting in the dispute became evident. If the Contractor fails to provide the TIA and/or fails to document such delay in the next regular Monthly Progress Schedule submission, the State shall have no liability as part of any subsequent Contractor request for time related dispute damages for any damages resulting during the time period following the date on which actions resulting in the dispute occurred or conditions resulting in the dispute became evident until the Contractor began properly documenting delays contemporaneously in their Monthly Progress Schedule submissions.

**E. Compensable or Excusable Delays**

When delays are determined by the Engineer to be compensable or excusable, the Contractor may be directed to either submit a request for an extension of the contract completion date and/or a request to accelerate work along with a schedule revision.

**F. Delay Mitigation**

If the Contractor's work falls behind schedule and the delay is neither compensable nor excusable, and the Contractor cannot complete the work within the time prescribed under §108-02 *Completion Date*, as modified pursuant to §109-05 *Extra Work And Time Related Compensation and §108-04 Delay Provisions*, the Contractor shall take such steps as may be necessary to improve its progress. The Contractor shall consider as a minimum the following potential schedule mitigation techniques: increase the number of shifts, begin overtime operations, work extra days including weekends and holidays, or supplement its construction plant and to submit for approval a recovery schedule or schedules, as may be deemed necessary to demonstrate the manner in which the agreed rate of progress shall be regained, all at no cost to the State. If the delay can not be mitigated, the Contractor shall submit a request for an extension of the contract completion date.

**SPECIAL NOTE  
ASBESTOS REMOVAL  
SUPPLEMENTAL REQUIREMENTS  
PIN 8062.10**

This Special Note applies specifically to the following payment Items:

**210.3312 - Removal and Disposal of Bond Breaker/Filler ACM (BV14), Square Foot**

All requirements of this Special Note are hereby made part of the requirements of the referenced payment items. All Contractor costs associated with these requirements will be included in the price bid for the pay items.

**1. General Certification and Licensing Requirements**

The Contractor shall note that the project involves asbestos removal. The Contractor performing the asbestos removal shall be a licensed New York State asbestos abatement contractor. All persons involved in performing the asbestos abatement work shall be properly and appropriately certified as identified in Subpart 56-3 of the New York State Department of Labor Industrial Code Rule 56 (ICR 56), and shall comply with all applicable laws, rules, and regulations. This includes all individuals involved in all portions of the asbestos work, including managing, supervising, designing, inspecting and/or performing the work.

**2. Preparatory Actions**

No demolition, remodeling, renovation, or repair work shall commence on the structure until all necessary asbestos abatements have occurred. All Asbestos-containing Material (ACM), Presumed ACM (PACM), or Suspect ACM (SACM) impacted by demolition, remodeling, renovation, or repair of the structure shall be removed as per ICR 56 prior to access or disturbance by uncertified trades or personnel. If any construction activities reveal additional or previously unidentified ACM, PACM, or SACM, then all activities shall cease in the area where the materials are observed until appropriate abatement actions of those materials are completed.

**3. Location of Asbestos Containing Material**

The following asbestos-containing materials (ACM) have been identified:

<b>Site</b>	<b>BIN</b>	<b>Bridge Location</b>	<b>ACM Present</b>	<b>ACM Quantity</b>
1	1032621	I-84 (WB)	Bond Breaker slip sheet	70 ft <sup>2</sup>
2	1032622	I-84 (EB)	Bond Breaker slip sheet	70 ft <sup>2</sup>

The location of the ACM is detailed in the Asbestos Assessment Report, June 2008, which can be reviewed at NYSDOT Region 8 office.

The Contractor shall verify the location of the ACM and any asbestos debris and/or

contaminated materials that may be in the vicinity of the bridge abutments.

These quantity estimates represent only an approximation for the convenience of the contractor in estimating the overall extent of asbestos removal required.

#### 4. **Pre-Abatement Meeting**

This project requires a pre-abatement meeting. The Engineer-In-Charge (EIC) shall invite all parties involved with the project to this meeting.

Before the pre-abatement meeting, the Contractor is required to submit to the EIC the following information:

- A. A valid New York State Department of Labor (NYSDOL) Asbestos Handling License;
- B. Copies of NYSDOL Handlers and Supervisors Certificates;
- C. Copies of all current respirator fit tests and medical exam certifications;
- D. Asbestos waste hauler documentation and a copy of NYS DEC Part 364 permit;
- E. NYSDOL, EPA, local (if applicable) notifications. Notifications must be in place a minimum of 10 days prior to the start of the job;
- F. NYSDOL asbestos handling license for OSHA monitoring firm;
- G. Copies of NYSDOH ELAP registrations for OSHA monitoring analysis laboratory;
- H. Insurance coverage documentation consistent with Section 107-06;
- I. Emergency contact numbers;
- J. Detailed project schedule and work plan, including all phases;
- K. Name of EPA approved landfill as well as copies of all permits;
- L. Copies of all Regulatory Variances to be used for Abatement work.

#### 5. **Notification**

The EIC shall notify the NYSDOT Regional Construction Environmental Coordinator at least ten (10) business days before the Pre-Abatement Meeting is scheduled for this project.

The Contractor shall notify the EIC no later than forty-five (45) calendar days prior to the scheduled abatement of the ACM.

#### 6. **Abatement**

The Contractor shall perform abatement procedures on the:

- **Bond Breaker slip sheet** utilizing **Item Number 210.3312**

The Contractor shall base its bid upon the quantity of these materials at their respective locations in their undisturbed states, and be paid based upon the quantity of these materials at their respective locations.

The Contractor shall be paid only for actually removed quantities of asbestos materials, to be quantified in the field, and to be verified by the Engineer in charge (EIC). If additional asbestos containing materials are identified during construction/demolition activities that are not identified in asbestos abatement design, the Contractor shall be

paid for the removal of these materials at the NYSDOT approved unit cost agreed upon in this contract.

The Contractor is responsible for removing the ACM in accordance with Industrial Code Rule 56 and following the approved identified variance, Blanket Variance 14 (BV14) provided separately as variance File Number 09-0440, or per a Site Specific Variance (SSV) yet to be prepared.

The Contractor is responsible for planning the removal, including scoping, timing, phasing, and removal methods to be utilized. All removal operations shall be performed within the context of the general construction staged operation. Any necessary sampling (for OSHA compliance) and analysis shall be performed by the Contractor.

Removal of asbestos-contaminated debris shall be part of the asbestos project and be performed by certified persons.

The Contractor shall progress the abatement project without stopping to initiate another project.

#### **7. Compliance Air Monitoring**

The Contractor shall **not** include in his/her bid the asbestos abatement Project and/or Air Monitoring services as required under Subpart 56-4 of ICR 56. NYSDOT shall provide the Project and/or Air Monitoring via use of a Consultant.

#### **8. Project Documentation**

The Contractor shall provide the EIC with two (2) complete sets of record documents, including chain-of-custody records, worker sign in/sign out sheets, proof of worker certifications, and other such records requested or as required by law to be kept on record. These records shall be assembled as a single, logical report, with all information bound together.

#### **9. Post-Abatement**

After successful completion of post-abatement clearance air monitoring (if required) and the removal of the decontamination facilities of the ACM abatement, uncertified persons may re-enter the work area(s).

The project will be considered to be complete, and final payments may be dispersed, only after receipt of the NYSDOT Asbestos Representative's (Project Monitor) final report (Abatement Closure Report). This report will only be distributed from the NYSDOT Representative upon the Representative's receipt and verification of all asbestos Contractor's close-out documentation (i.e., waste manifests, daily logs, sign-in/sign-out sheets, and OSHA air monitoring results). Only legible copies of the waste manifest(s) will be accepted.

END OF SPECIAL NOTES

**SPECIAL NOTE  
SPECIAL SPECIFICATION PAY ITEM NUMBERS  
PIN 8062.10**

The contractor’s attention is directed to the special specification pay item formats used in this contract. Special specification pay items may be presented in three different formats:

- Format 1. Pay items for a special specification will have five digits to the left of the decimal point and up to six digits to the right of the decimal point. The two left-most digits represent the origin of the specification. Reference Standard Specification §101-02 Specifications.
- Format 2. Pay items for a special specification will have three digits to the left of the decimal point and up to eight digits to the right of the decimal. Spaces may appear in the third to sixth places after the decimal. The 7th and 8th digits to the right of the decimal will represent the origin of the specification.
- Format 3. Pay items for a special specification will have three digits to the left of the decimal point and up to eight digits to the right of the decimal. Dashes may appear in the third to sixth places after the decimal. The 7th and 8th digits to the right of the decimal will represent the origin of the specification.

Where items in this contract appear in multiple formats, the formats shall be equated to each other as illustrated below:

Format 1	Format 2	Format 3
XXXXX.XX	XXX.XX XX	XXX.XX----XX
XXXXX.XXXX	XXX.XXXX XX	XXX.XXXX--XX
XXXXX.XXXXXX	XXX.XXXXXXXX	XXX.XXXXXXXX

**SPECIAL NOTE  
PRE-AWARD SUBMITTAL REVIEW  
PIN 8062.10**

The Contractor is advised that NYSDOT will review any submittals the Contractor chooses to make prior to award. However, any submittal the Contractor makes prior to award will be at the Contractor’s own risk without obligation or responsibility on the part of the State unless and until the awarded contract becomes effective.

**Route: I-84**

Required Number of Lanes by Time of Day

Eastbound		Segment		To:		RM		MM		Normal	
RM	MM	From:	To:	RM	MM	# Lanes	00:00	06:00	10:00	15:00	20:00
84I 8403 1069	65.4	Exit 19 - Rt 312	Exit 20 - I-684	84I 8403 1099	68.3	2	1	2	1	2	1
84I 8403 1099	68.3	Exit 20 - I-684	Exit 21 - Rt 121	84I 8403 1108	69.2	2	1	2	2	2	2
84I 8403 1108	69.2	Exit 21 - Rt 121	CT State Line	84I 8403 1130	71.4	2	1	2	2	2	2
Westbound		Segment		To:		RM		MM		Normal	
RM	MM	From:	To:	RM	MM	# Lanes	00:00	05:00	06:00	10:00	15:00
84I 8403 1130	71.4	CT State Line	Exit 21 - Rt 121	84I 8403 1108	69.2	2	1	2	2	2	2
84I 8403 1108	69.2	Exit 21 - Rt 121	Exit 20 - I-684	84I 8403 1099	68.3	2	1	2	2	2	2
84I 8403 1099	68.3	Exit 20 - I-684	Exit 19 - Rt 312	84I 8403 1069	65.4	2	1	1	2	1	2
84I 8403 1069	65.4	Exit 19 - Rt 312	Exit 18 - Rt 311	84I 8403 1033	61.8	2	1	1	2	1	2

Red - All lanes must be open.

All Other Areas - One open lane is sufficient.

**Route: I-684**

Required Number of Lanes by Time of Day

Monday through Thursdays (All northbound lanes should be open from 1200 to 1900 on Fridays and days preceding Holidays and Holiday Weekends)

Northbound		Segment		To:		RM		MM		Normal	
RM	MM	From:	To:	RM	MM	# Lanes	00:00	09:00	16:00	20:00	23:00
684I 8701 1223	22.3	Route 116	Putnam Co Line	684I 8402 1000	25.0	3	1	2	3	2	2
684I 8402 1000	25.0	Putnam Co Line	JCT RT 6	684I 8402 1035		3	1	2	3	2	2
Southbound		Segment		To:		RM		MM		Normal	
RM	MM	From:	To:	RM	MM	# Lanes	00:00	06:00	07:00	10:00	21:00
684I 8402 1035		JCT RT 6	Putnam Co Line	684I 8402 1000	25.0	3	1	2	3	2	1
684I 8402 1000	25.0	Putnam Co Line	Route 116	684I 8701 1223	22.3	3	1	2	3	2	1

Note: Average capacities for lanes in work zones taken from Table 9.1 of publication FHWA-HI-96-037 (source "Highway Capacity Manual, Special Report 209")

Red - All lanes must be open.

Orange - The closing of only one lane is permissible for 3 lane segments.

All Other Areas - multiple lanes closures are permissible for 3 lane segments.



**SPECIAL NOTE  
BUY AMERICA WAIVER  
PIN 8062.10**

NYSDOT has requesting a waiver from the Buy America provision for Micro Steel Fibers to be used in Ultra High Performance Concrete (UHPC) and we expect FHWA concurrence prior to the letting date.



**ITEM 207.96000017 - GEOSYNTHETIC REINFORCEMENT****DESCRIPTION**

This work shall consist of providing and installing Geosynthetic Reinforcement (GR) as indicated on the plans or as directed in writing by the Engineer.

**MATERIALS**

Provide certified tested GR meeting the minimum wide width tensile strength in two perpendicular directions at 5% strain shown on the plans.

**CONSTRUCTION DETAILS**

Protect the GR from exposure to sunlight during transport and storage. After placement, the GR shall not be left uncovered for more than two weeks.

Place the GR at the proper elevation and alignment as shown on the plans or as directed by the Engineer. The surface upon which the GR is to be placed shall be within reasonable conformity to the proposed grade.

GR sections shall be overlapped a minimum of 1 foot or as directed by the Engineer. Care shall be taken to ensure that GR sections do not separate at overlaps during construction. Place the GR without folds.

The placement of the GR around corners may require cutting the material and diagonal overlapping of the GR to ensure that excessive buckling or folding of the GR material does not occur.

Place the overlying course(s) and compact as shown on the plans or as approved by the Engineer. Traffic or construction equipment will not be permitted directly on the GR.

**METHOD OF MEASUREMENT**

This work will be measured as the number of square feet of GR computed from the payment lines shown on the plans or from payment lines established in writing by the Engineer. Measurement will not be made for GR used for repairs or overlaps.

**BASIS OF PAYMENT**

The unit price bid shall include the cost of furnishing all labor, materials, and equipment necessary to satisfactorily complete the work.

**ITEM 304.1100008 - SUBBASE COURSE (MODIFIED)**

All specification requirements for Item 304.11 shall apply with the following addition:

At his option, the contractor may substitute Type 2 material, as specified in Section 304-2.02 of the Standard Specifications. There will be no change in the price bid if the contractor elects to make this substitution.

**ITEM 404.XXYZQ108 – WARM MIX ASPHALT**

**DESCRIPTION.** This work shall consist of developing, producing and paving a Warm Mix Asphalt (WMA) mixture. WMA is standard HMA produced using a WMA technology typically resulting in a production mixture temperature of 275°F or lower.

WMA pavement course shall be constructed in accordance with this specification and in reasonably close conformity with the required lines, grades, thicknesses, and typical sections shown on the plans or established by the Engineer. The Contractor is responsible for compacting pavement to a specified density requirement.

The words “hot mix asphalt” and “HMA” in the standard specifications and other documents referenced by this specification shall apply to WMA.

**MATERIALS.** Requirements of §401-2 and §402-2 shall apply except as noted herein.

**WMA Technology.** Use a WMA technology appearing on the State’s Approved List for Warm Mix Asphalt Technologies.

**WMA Design.** Design a mixture using a WMA Technology in accordance with MM 5.16, *Superpave Hot Mix Asphalt Mixture Design and Mixture Verification Procedure*. At a minimum, a one point verification of the mixture’s volumetric properties is acceptable for the following situations:

- When the WMA mix design is based on an existing Production Status HMA mix design.
- When the WMA mix design utilizes a different WMA technology than an existing Production Status WMA mix design.

Comply with the manufacturer’s recommendations for incorporating the WMA technology. Notify the Regional Material Engineer (RME) how the WMA technology will be incorporated prior to fabricating the test specimens. Test specimens may be made from plant produced or laboratory prepared WMA. Test specimens must be made from plant produced WMA if adding the WMA technology in the lab does not simulate the production process. The RME may require a State representative be present during the fabrication and testing. Submit the WMA design to the RME for review and verification at least 14 calendar days before production, including:

- Name of WMA technology being used and the target dosage rate.
- If using an additive other than water,
  - Submit a MSDS for the additive.
  - Submit either enough of the additive for the laboratory mix design verification, or the additive pre-blended in the PG Binder at the correct dosage. If the additive is not pre-blended into the PG Binder, include directions for properly incorporating the additive into the laboratory made mixture.
- Prior to the submission of any mix design, contact the RME to determine if there is an increased concern regarding the mixture’s moisture susceptibility based on the WMA technology and/or the type of aggregate being used, or the performance of similar mixes. The RME may require AASHTO T 283 moisture susceptibility test results, meeting a minimum Tensile Strength Ration (TSR) of 80%, as part of the mix design submission.

Production Quality Control Plan revisions incorporating the WMA technology if not previously submitted.

**CONSTRUCTION DETAILS.** Requirements of §401-3 and §402-3 shall apply except as noted herein.

**Mix Temperature.** Select a desired WMA mixture temperature within the mixing and compaction range as recommended by the WMA technology provider. If the asphalt mixture is being placed over a

**ITEM 404.XXYZQ108 – WARM MIX ASPHALT**

*Sheet-Applied Waterproofing Membrane*, maintain a minimum delivery temperature in accordance with the Material Detail Sheets prepared by the membrane manufacturer.

For 80 Series compaction method, complete all breakdown roller passes before the mat temperature falls below 230° F, unless approved by the Director, Materials Bureau.

**METHOD OF MEASUREMENT.** Requirements of §401-4 and §402-4 shall apply.

**BASIS OF PAYMENT.** The unit price bid for WMA mixtures shall meet the requirements specified in §402-5 Basis of Payment

<b>Item No.</b>	<b>Item</b>	<b>Pay Unit</b>
404.01090108	Type 1 F9, Asphalt-Treated Permeable Base Course	Ton
404.01091108	Plant Production Quality Adjustment to 404.01090108	Quality Unit
404.01190108	Type 2 F9, Asphalt-Treated Permeable Base Course	Ton
404.01191108	Plant Production Quality Adjustment to 404.01190108	Quality Unit
404.01790108	True & Leveling F9, Superpave WMA, 70 Series Compaction	Ton
404.01791108	Plant Production Quality Adjustment to 404.01790108	Quality Units
404.01890108	True & Leveling F9, Superpave WMA, 80 Series Compaction	Ton
404.01891108	Plant Production Quality Adjustment to 404.01890108	Quality Units
404.05890108	Shim Course F9, Warm Mix Asphalt	Ton
404.05891108	Plant Production Quality Adjustment to 404.05890108	Quality Unit
404.09510108	9.5 F1 Superpave WMA, 50 Series Compaction	Ton
404.09511108	Plant Production Quality Adjustment to 404.09510108	Quality Units
404.09512108	Pavement Density Quality Adjustment to 404.09510108	Quality Units
404.09515108	Test Section Adjustment to 404.09510108	Quality Units
404.09520108	9.5 F2 Superpave WMA, 50 Series Compaction	Ton
404.09521108	Plant Production Quality Adjustment to 404.09520108	Quality Units
404.09522108	Pavement Density Quality Adjustment to 404.09520108	Quality Units
404.09525108	Test Section Adjustment to 404.09520108	Quality Units
404.09610108	9.5 F1 Superpave WMA, 60 Series Compaction	Ton
404.09611108	Plant Production Quality Adjustment to 404.09610108	Quality Units
404.09612108	Pavement Density Quality Adjustment to 404.09610108	Quality Units
404.09615108	Test Section Adjustment to 404.09610108	Quality Units
404.09620108	9.5 F2 Superpave WMA, 60 Series Compaction	Ton
404.09621108	Plant Production Quality Adjustment to 404.09620108	Quality Units
404.09622108	Pavement Density Quality Adjustment to 404.09620108	Quality Units
404.09625108	Test Section Adjustment to 404.09620108	Quality Units
404.09630108	9.5 F3 Superpave WMA, 60 Series Compaction	Ton
404.09631108	Plant Production Quality Adjustment to 404.09630108	Quality Units
404.09632108	Pavement Density Quality Adjustment to 404.09630108	Quality Units
404.09635108	Test Section Adjustment to 404.09630108	Quality Units
404.09710108	9.5 F1 Superpave WMA, 70 Series Compaction	Ton
404.09711108	Plant Production Quality Adjustment to 404.09710108	Quality Units
404.09720108	9.5 F2 Superpave WMA, 70 Series Compaction	Ton
404.09721108	Plant Production Quality Adjustment to 404.09720108	Quality Units
404.09730108	9.5 F3 Superpave WMA, 70 Series Compaction	Ton
404.09731108	Plant Production Quality Adjustment to 404.09730108	Quality Units
404.09810108	9.5 F1 Superpave WMA, 80 Series Compaction	Ton

**ITEM 404.XYZQ108 – WARM MIX ASPHALT**

404.09811108	Plant Production Quality Adjustment to 404.09810108	Quality Units
404.09820108	9.5 F2 Superpave WMA, 80 Series Compaction	Ton
404.09821108	Plant Production Quality Adjustment to 404.09820108	Quality Units
404.09830108	9.5 F3 Superpave WMA, 80 Series Compaction	Ton
404.09831108	Plant Production Quality Adjustment to 404.09830108	Quality Units
404.09890108	9.5 F9 Superpave WMA, Shoulder Course, 80 Series Compaction	Ton
404.09891108	Plant Production Quality Adjustment to 404.09890108	Quality Units
404.12510108	12.5 F1 Superpave WMA, 50 Series Compaction	Ton
404.12511108	Plant Production Quality Adjustment to 404.12510108	Quality Units
404.12512108	Pavement Density Quality Adjustment to 404.12510108	Quality Units
404.12515108	Test Section Adjustment to 404.12510108	Quality Units
404.12520108	12.5 F2 Superpave WMA, 50 Series Compaction	Ton
404.12521108	Plant Production Quality Adjustment to 404.12520108	Quality Units
404.12522108	Pavement Density Quality Adjustment to 404.12520108	Quality Units
404.12525108	Test Section Adjustment to 404.12520108	Quality Units
404.12610108	12.5 F1 Superpave WMA, 60 Series Compaction	Ton
404.12611108	Plant Production Quality Adjustment to 404.12610108	Quality Units
404.12612108	Pavement Density Quality Adjustment to 404.12610108	Quality Units
404.12615108	Test Section Adjustment to 404.12610108	Quality Units
404.12620108	12.5 F2 Superpave WMA, 60 Series Compaction	Ton
404.12621108	Plant Production Quality Adjustment to 404.12620108	Quality Units
404.12622108	Pavement Density Quality Adjustment to 404.12620108	Quality Units
404.12625108	Test Section Adjustment to 404.12620108	Quality Units
404.12630108	12.5 F3 Superpave WMA, 60 Series Compaction	Ton
404.12631108	Plant Production Quality Adjustment to 404.12630108	Quality Units
404.12632108	Pavement Density Quality Adjustment to 404.12630108	Quality Units
404.12635108	Test Section Adjustment to 404.12630108	Quality Units
404.12710108	12.5 F1 Superpave WMA, 70 Series Compaction	Ton
404.12711108	Plant Production Quality Adjustment to 404.12710108	Quality Units
404.12720108	12.5 F2 Superpave WMA, 70 Series Compaction	Ton
404.12721108	Plant Production Quality Adjustment to 404.12720108	Quality Units
404.12730108	12.5 F3 Superpave WMA, 70 Series Compaction	Ton
404.12731108	Plant Production Quality Adjustment to 404.12730108	Quality Units
404.12810108	12.5 F1 Superpave WMA, 80 Series Compaction	Ton
404.12811108	Plant Production Quality Adjustment to 404.12810108	Quality Units
404.12820108	12.5 F2 Superpave WMA, 80 Series Compaction	Ton
404.12821108	Plant Production Quality Adjustment to 404.12820108	Quality Units
404.12830108	12.5 F3 Superpave WMA, 80 Series Compaction	Ton
404.12831108	Plant Production Quality Adjustment to 404.12830108	Quality Units
404.12890108	12.5 F9 Superpave WMA, Shoulder Course, 80 Series Compaction	Ton
404.12891108	Plant Production Quality Adjustment to 404.12890108	Quality Units
404.19590108	19 F9 Superpave WMA, 50 Series Compaction	Ton
404.19591108	Plant Production Quality Adjustment to 404.19590108	Quality Units
404.19592108	Pavement Density Quality Adjustment to 404.19590108	Quality Units
404.19595108	Test Section Adjustment to 404.19590108	Quality Units
404.19690108	19 F9 Superpave WMA, 60 Series Compaction	Ton
404.19691108	Plant Production Quality Adjustment to 404.19690108	Quality Units
404.19692108	Pavement Density Quality Adjustment to 404.19690108	Quality Units
404.19695108	Test Section Adjustment to 404.19690108	Quality Units
404.19790108	19 F9 Superpave WMA, 70 Series Compaction	Ton

ITEM 404.XYZQ108 – WARM MIX ASPHALT

404.19791108	Plant Production Quality Adjustment to 404.19790108	Quality Units
404.19890108	19 F9 Superpave WMA, 80 Series Compaction	Ton
404.19891108	Plant Production Quality Adjustment to 404.19890108	Quality Units
404.25590108	25 F9 Superpave WMA, 50 Series Compaction	Ton
404.25591108	Plant Production Quality Adjustment to 404.25590108	Quality Units
404.25592108	Pavement Density Quality Adjustment to 404.25590108	Quality Units
404.25595108	Test Section Adjustment to 404.25590108	Quality Units
404.25690108	25 F9 Superpave WMA, 60 Series Compaction	Ton
404.25691108	Plant Production Quality Adjustment to 404.25690108	Quality Units
404.25692108	Pavement Density Quality Adjustment to 404.25690108	Quality Units
404.25695108	Test Section Adjustment to 404.25690108	Quality Units
404.25790108	25 F9 Superpave WMA, 70 Series Compaction	Ton
404.25791108	Plant Production Quality Adjustment to 404.25790108	Quality Units
404.25890108	25 F9 Superpave WMA, 80 Series Compaction	Ton
404.25891108	Plant Production Quality Adjustment to 404.25890108	Quality Units
404.37690108	37.5 F9 Superpave WMA, 60 Series Compaction	Ton
404.37691108	Plant Production Quality Adjustment to 404.37690108	Quality Units
404.37692108	Pavement Density Quality Adjustment to 404.37690108	Quality Units
404.37695108	Test Section Adjustment to 404. 37690108	Quality Units
404.37790108	37.5 F9 Superpave WMA, 70 Series Compaction	Ton
404.37791108	Plant Production Quality Adjustment to 404.37790108	Quality Units
404.37890108	37.5 F9 Superpave WMA, 80 Series Compaction	Ton
404.37891108	Plant Production Quality Adjustment to 404.37890108	Quality Units



**ITEM 520.50140008 - SAW CUTTING ASPHALT PAVEMENT, CONCRETE PAVEMENT  
AND ASPHALT OVERLAY ON CONCRETE PAVEMENT****DESCRIPTION:**

Under this item, the contractor shall saw cut existing asphalt pavement, concrete pavement, asphalt surface course, or asphalt concrete overlay on concrete pavement at the locations indicated on the plans or where directed by the Engineer.

**MATERIALS:**

None specified.

**CONSTRUCTION DETAILS:**

Existing pavement and overlay shall be saw cut perpendicular to the roadway surface along neat lines, and to the depth indicated on the plans and typical sections. A power saw approved by the Engineer shall be used for cutting asphalt surface course and asphalt overlay. A power saw shall be used for cutting concrete pavement. After the existing asphalt pavement, concrete pavement, asphalt surface course or overlay has been saw cut through, the contractor may use pry bars, pneumatic tools or other methods approved by the Engineer, to pry loose the existing pavement from that pavement which is to remain. A pavement breaker, under the supervision of the Engineer, may be used to break up the pavement to be removed after the pavement has been completely saw cut through and completely free from the pavement to remain.

Any existing pavements and curbs not indicated to be removed that are damaged by the contractor's operations, shall be repaired by him to the satisfaction of the Engineer at no additional cost to the State.

**METHOD OF MEASUREMENT:**

The quantity to be measured will be the number of feet of saw cutting done in accordance with the plans, typical sections and the directions of the Engineer.

No saw cutting will be measured for payment under this item which the contractor may choose to do for his own convenience.

**BASIS OF PAYMENT:**

The unit price bid per feet of saw cutting shall include the cost of all labor, materials, and equipment necessary to complete the work.

Payment for removal and disposal of cut pavement shall be paid for under the appropriate excavation item.

ITEM 551.60000017 - FURNISHING EQUIPMENT FOR INSTALLING DRILLED SHAFTS

ITEM 551.61000017 - FURNISHING EQUIPMENT FOR INSTALLING DRILLED SHAFTS (ON WATER)

ITEM 551.62000017 - FURNISHING EQUIPMENT FOR INSTALLING DRILLED SHAFTS (LOW OVERHEAD CLEARANCE)

### DESCRIPTION

This work shall consist of furnishing the necessary equipment, including barges, platforms, and support vessels, for installing drilled shafts as shown on the plans.

### MATERIALS

Not specified.

### CONSTRUCTION DETAILS

Prior to delivering any equipment to the site, submit the proposed type of equipment for drilled shaft installation to the Deputy Chief Engineer Structures (DCES) for review and approval. The DCES will render a decision within 15 working days, measured from the date of receipt of all information.

Provide equipment capable of installing drilled shafts with lengths 20% greater than those shown on the plans. Provide equipment capable of accessing holes on water and progressing holes through soils at the site which may include miscellaneous fill, boulders, timber and other obstructions, and into bedrock. Remove all equipment from the site deemed unsatisfactory by the DCES and replace it with satisfactory equipment at no additional cost to the State.

Provide equipment capable of installing drilled shafts, given the low overhead clearance conditions at the site.

### METHOD OF MEASUREMENT

Payment will be made by lump sum. No field measurements will be taken.

### BASIS OF PAYMENT

The unit price bid shall include the cost of furnishing all labor, materials and equipment, including barges, platforms and support vessels, necessary for transporting, erecting, maintaining, making any ordered equipment replacement, dismantling and removing all installation equipment.

Payment will be made as follows: Seventy-five percent (75%) of the amount bid will be authorized for payment when the equipment for installing drilled shafts is furnished and the installation of drilled shafts has commenced. The remainder will be authorized for payment when the work of installing the drilled shafts is completed.

Payment will be made under:

<b>Item No.</b>	<b>Item</b>	<b>Pay Unit</b>
551.60000017	Furnishing Equipment for Installing Drilled Shafts	Lump Sum
551.61000017	Furnishing Equipment for Installing Drilled Shafts (On Water)	Lump Sum
551.62000017	Furnishing Equipment for Installing Drilled Shafts (Low Overhead Clearance)	Lump Sum

**DESCRIPTION**

This work shall consist of conducting Crosshole Sonic Logging (CSL) on drilled shafts where indicated on the plans or where ordered by the Engineer and report the results. The selection of the testing organization is subject to the approval of the Deputy Chief Engineer Technical Services (DCETS). The CSL test is used to evaluate the integrity of the shaft concrete by measuring the response of an ultrasonic pulse traveling from a signal source in one access pipe to a receiver in another access pipe.

**MATERIALS**

**A. Access Pipes.** Provide access pipes with the material and dimensions specified in the contract documents. Provide pipes with a round and constant internal diameter free of defects or obstructions, including any at pipe joints. Use watertight pipes free from corrosion with clean internal and external surfaces. Equip each pipe with a watertight threaded cap on the bottom and a removable threaded cap on the top.

**B. Grout.** Provide cement or sand-cement grout for filling access pipes. The Contractor's proposed grouting methods and grout mixes are subject to the approval of the Engineer. All grout constituents must meet the material requirements of §700 Materials and Manufacturing.

**C. Water.** Provide water that meets the requirements of §712-01 Water.

**CONSTRUCTION DETAILS**

**A. Equipment.** Provide CSL equipment which consists of the following components:

1. A microprocessor based CSL system for display of individual CSL records, analog-digital conversion and recording of CSL data, analysis of receiver responses and printing of CSL logs.
2. Ultrasonic source and receiver probes for 1-1/2 inch or 2 inch I.D. pipe, as appropriate.
3. An ultrasonic voltage pulser to excite the source with a synchronized triggering system to start the recording system.
4. A measurement device to determine the depth of records.
5. Appropriate filter/amplification and cable systems for CSL testing.

**B. Procedure**

1. **Access Pipes.** Install the access pipes in the shafts specified to be tested as per the contract plans. The number of pipes per shaft and location of the pipes within the shaft is detailed on the plans. Secure the pipes to the rebar cage prior to the placement of the cage in the shaft.

After placement of the reinforcement cage, fill the pipes with water before or immediately after concrete placement and cap the pipe tops. The pipes shall be parallel to the longitudinal axis of shaft. Exercise care in the removal of caps from the pipes after installation of the shaft concrete so as not to apply excess stress that may break the bond between the pipes and the concrete.

**2. CSL Testing.** Provide the shaft toe and top elevations, along with construction dates to the testing organization prior to the CSL testing. Conduct CSL tests between pairs of pipes, in the pair configurations shown on the plans. Additional tests may be conducted in the event any anomalies are detected in the specified logs.

Remove slack from the cables prior to raising the probes to provide for accurate depth measurement in the CSL records. Raise the probes simultaneously, starting from the bottom of the access pipes. Take CSL measurements from the toe to the top of each shaft at intervals of 0.2 feet. Conduct the CSL testing with the source and receiver probes in the same horizontal plane unless test results indicate potential anomalies/defects in which case the questionable zone may be further evaluated with angled tests (source and receiver vertically offset in the pipes). Report anomalies/defects indicated by longer pulse arrival times and significantly lower energy/amplitude signals to the Engineer at the time of testing.

**3. Test Results.** Provide a preliminary report to the DCETS within two working days and a final report within five working days of completion of the testing at each substructure.

Include in the test results CSL logs with analyses of:

- a. Initial pulse arrival time or compression wave velocity versus depth.
- b. Pulse energy/amplitude versus depth.

Present a CSL log for each pipe pair tested and discuss any anomaly/defect zones in the report as appropriate.

If the CSL test reveals defects in the concrete, the defects will be accessed by coring and will be repaired. The repair procedure is subject to the approval of the Engineer. Additional CSL testing will be conducted at the Contractor's expense to verify the repair of the defects.

**4. Acceptance.** Upon completion of the CSL testing and acceptance of the drilled shafts by the DCETS, remove the water from the access pipes and fill the pipes to the top of the drilled shaft with a cement or sand-cement grout. Cut off the pipes flush with the top of the drilled shaft.

#### **METHOD OF MEASUREMENT**

This work will be measured as the number of drilled shafts on which CSL testing is performed and found to be free of defects which require repair as deemed by the DCETS in accordance with the specification.

**BASIS OF PAYMENT**

The unit price bid shall include the cost of furnishing all labor, materials and equipment necessary to perform CSL testing and report the results. The cost of repairing possible defects in the shaft concrete and additional CSL testing to verify the effectiveness of the repairs is at the Contractor's expense.

ITEM 551.99495508 - DRILLED SHAFTS

ITEM 551.XXXXNNRR - DRILLED SHAFTS (LOW OVERHEAD CLEARANCE)

ITEM 551.XXXXXXRR - TRIAL SHAFTS

## DESCRIPTION

**A. General.** This work shall consist of furnishing the materials and installing drilled shafts at the locations, dimensions, and batters shown on the contract plans or where ordered by the Engineer and approved by the Deputy Chief Engineer Structures (DCES). This work includes excavating shafts, disposing of all excavated material and drilling mud, placing steel reinforcement, and placing concrete as detailed.

The intent of this work is for the Contractor or subcontractor to provide reinforced concrete shafts in cylindrical excavated holes which extend a sufficient depth into the soil and/or rock to support the structure and all externally applied loads for which it was designed.

The Contractor or subcontractor performing this work must have had prior experience installing drilled shafts, as described in this specification.

**B. Definitions.** Definitions that apply within this specification are:

**Contractor.** The contractor or subcontractor performing the work described in this specification.

**Casing (Shell).** A steel shell used to construct the drilled shaft. The casing can help advance the hole, and supports the sides of the hole. Casing can be permanent, interim or temporary.

**Casing Method.** A method of shaft construction, consisting of advancing and cleaning a cased hole, placing the reinforcing cage, and concreting the shaft while extracting temporary casing (if used).

**Drilling Mud.** A slurry made using bentonite or polymers (see Slurry).

**Drilled Shaft.** A cylindrical structural column transmitting loads to soil and/or rock. The drilled shaft is constructed in a hole with a circular cross section. The hole is filled with concrete and may be reinforced with steel.

**Dry Construction Method.** A method of shaft construction consisting of drilling the shaft, removing water and material from the excavation, placing the reinforcing cage, and concreting the shaft in a relatively dry condition.

**Interim Casing.** A casing that acts as a form, but remains in place permanently. It is not designed to carry structural loads.

ITEM 551.99495508 - DRILLED SHAFTSITEM 551.XXXXNNRR - DRILLED SHAFTS (LOW OVERHEAD CLEARANCE)ITEM 551.XXXXXXRR - TRIAL SHAFTS

**Permanent Casing.** A casing that is designed to carry structural loads. It acts as a form and remains in place permanently.

**Quality Assurance.** A test or procedure that acts to verify the quality of the work or product. Quality Assurance procedures would include static load testing, Osterberg cell testing, coring, cross hole sonic logging, and other non-destructive testing.

**Rock.** Rock is identified in the boring logs. Rock may also be defined at the shaft installation site by a Departmental Engineering Geologist.

**Seat.** The act of placing the tip of a casing in intimate contact on rock for its entire circumference.

**Slurry.** A mixture of water and bentonite, or water and polymers, which provides hydrostatic pressure that supports the sides and bottom of the hole, lubricates and cools the drill tools, and aids clean-out. Slurry cannot be made from native materials, or material from the excavation.

**Surface Casing.** Temporary casing installed to prevent sloughing of the surrounding soil near the surface of the shaft excavation.

**Temporary Casing.** A casing that serves its function during construction of the drilled shafts. It serves no permanent structural function, and is extracted during concreting.

**Top of Socket.** The highest location of the rock socket that is capable of resisting axial and lateral design loads. At any given location, the top of socket elevation is usually below the top of rock elevation. This distance depends on the type and quality of the rock, and the Contractors drilling methods and equipment.

**Tremie.** A method to place concrete under water. Refer to §555 - Structural Concrete.

**Trial Shaft.** A hole for a drilled shaft constructed on the project site, but outside the proposed footing limits. It is not to be incorporated into a structure or foundation. A trial shaft is constructed prior to installing production drilled shafts, according to the methods detailed in the Contractor's submittals. Its function is to verify the proposed excavation methods, and permit the Inspectors to become familiar with the excavation procedure.

Upon inspection and acceptance, the trial shaft is backfilled with unreinforced concrete.

**Wet Construction Method.** A method of shaft construction in which slurry is used to maintain stability of the hole while advancing the excavation to the final depth, placing the reinforcing cage, and concreting the shaft.

ITEM 551.99495508 - DRILLED SHAFTS

ITEM 551.XXXXNNRR - DRILLED SHAFTS (LOW OVERHEAD CLEARANCE)

ITEM 551.XXXXXXRR - TRIAL SHAFTS

## MATERIALS

**A. Permanent Casing.** Provide continuous permanent casing conforming to the limits shown on the contract plans.

Provide material conforming to the requirements of ASTM A252 Grade 2, unless specified otherwise in the contract plans. Furnish full length shells, consistent with requirements shown in the contract documents. Unless otherwise specified in the contract documents, use of spiral welded casing is not permitted.

If needed, equip casing with an appropriate casing shoe to enable installation of casing to the elevations shown on the contract plans.

**B. Interim Casing.** Provide interim casing capable of withstanding all handling and installation stresses. If needed, equip casing with an appropriate casing shoe to enable installation of casing to the depths necessary to construct the drilled shaft to the elevations shown on the contract plans.

**C. Temporary Casing.** Provide temporary casing capable of withstanding all handling and installation and extraction stresses. If needed, equip casing with an appropriate casing shoe to enable installation of casing to the depths necessary to construct the drilled shaft to the elevations shown on the contract plans.

**D. Reinforcing Steel.** Provide bar reinforcement meeting the requirements of Subsection 709-01, Bar Reinforcement Grade 60, or ASTM A615, "Deformed and Plain Carbon-Steel Bars for Concrete Reinforcement."

**E. Concrete.** Provide Portland cement concrete with a minimum compressive strength of 5,000 psi where specified on the Plans for structural concrete. The provisions of §555-2 shall apply, except as modified herein.

1. Use materials meeting the requirements of 501-2.02
2. Design a concrete mixture proportioned according to the American Concrete Institute Manual of Concrete Practice, ACI 211.1, Standard Practice for Selecting Proportions for Normal, Heavyweight, and Mass Concrete. Produce a homogeneous mixture of cement, pozzolan (fly ash or GGBFS), microsilica, fine aggregate, lightweight fine aggregate, coarse aggregate, air entraining agent, water-reducing and set-retarding admixture, and water as designed.



**ITEM 551.99495508 - DRILLED SHAFTS****ITEM 551.XXXXNNRR - DRILLED SHAFTS (LOW OVERHEAD CLEARANCE)****ITEM 551.XXXXXRR - TRIAL SHAFTS**

3. The designed concrete mixture shall meet the following requirements:
  - I. Strength - 28 day minimum compressive strength of 5,000 psi.
  - II. Slump – 5 ½” to 8 ½”.
  - III. Entrained Air - 5 to 8%.
  - IV. Water/Total Cementitious Material Ratio - 0.42 maximum.
  - V. Coarse aggregate shall be a maximum size of 0.75 inch
  - VI. Use Type I, I/II, II or Type SF cement. Use a total cementitious content of 500 #/cy to 600 #/cy. Use 15%-20% pozzolan (fly ash or GGBFS) and 6-10% microsilica by weight of cementitious materials. If Type SF Blended cement is used, the separate addition of microsilica is not required.
4. Perform mix development testing in accordance with ASTM C143, C231, C192 and C39, to assure all performance criteria can be achieved during production and placement.
5. At least 1 month prior to the start of any concrete placement, provide a copy of the proposed mixture design(s) and trial batch test results to the Director, Materials Bureau, submitted through the Regional Materials Engineer, for evaluation. Submit sufficient data to permit the Director to offer an informed evaluation. Include at least the following:
  - Concrete mix proportions.
  - Material sources. Also include fineness modulus and specific gravity for all aggregates.
  - Air content of plastic concrete.
  - Slump of plastic concrete.
  - Compressive strength at 7, 14, and 28 days, and at any other age tested or deemed necessary.

Do not interpret having a valid mixture design as approval of the mixture. Also, resubmit any proposed mixture design change to the Director, Materials Bureau, for evaluation. Multiple mixture designs may be used to address performance and placement issues as deemed necessary by the Contractor. Submit each mixture for evaluation, as indicated above, prior to use.

ITEM 551.99495508 - DRILLED SHAFTSITEM 551.XXXXNNRR - DRILLED SHAFTS (LOW OVERHEAD CLEARANCE)ITEM 551.XXXXXRR - TRIAL SHAFTS

**F. Centralizers.** Provide centralizers for properly aligning the steel reinforcement, made of a material that is not detrimental to the reinforcement or the concrete. The type of centralizer utilized must be approved by the DCES.

**G. Rebar Cage Feet.** Provide cylindrical feet to support the rebar cage at the proper elevation, made of a material that is not detrimental to the reinforcement or concrete. The type of feet utilized must be approved by the DCES.

**H. Protective Coating for Permanent Casing.** Provide a Coal Tar Epoxy-Polyimide Coating meeting the requirements of, and apply it in accordance with SSPC-PS 11.01: Black (or Dark Red) Coal Tar Polyimide Painting System. Apply the coating between the limits shown on the contract plans.

**I. Mineral Slurry.** Provide a mineral (bentonite) slurry that will remain in suspension, and with sufficient viscosity and gel characteristics to transport excavated material to a suitable screening system. Provide a slurry with the percentage and specific gravity of the material used to make the suspension sufficient to maintain the stability of the excavation and to allow proper concrete placement.

The acceptable range of values for mineral slurry is as follows:

Range of Values (68°F)			
Property (Units)	Time of Slurry Introduction	Time of Concreting (In hole)	Test Method
Density (lb/ft <sup>3</sup> )	64.3 to 69.1	64.3 to 75.0	Density Balance
Viscosity (seconds/quart)	28 to 45	28 to 45	Marsh Cone
pH	8 to 11	8 to 11	pH paper or meter

Increase density range values by 2 pcf in salt water.

Desand the slurry so that the sand content does not exceed 4 percent (by volume) prior to concrete placement as determined by the American Petroleum Institute sand content test.

**J. Polymer Slurry.** Provide a polymer slurry with sufficient viscosity and gel characteristics to hold the hole open, and transport excavated material to a suitable screening system.

Polymer slurry may be made from PHPA (emulsified), vinyl (dry), or natural polymers.

Desand the polymer slurry so that the sand content is less than 1 percent (by volume) prior to concrete placement, as determined by the American Petroleum Institute sand content test.

**ITEM 551.99495508 - DRILLED SHAFTS****ITEM 551.XXXXNNRR - DRILLED SHAFTS (LOW OVERHEAD CLEARANCE)****ITEM 551.XXXXXXRR - TRIAL SHAFTS**

**K. Water.** Provide water conforming to the requirements of §712-01 Water, except with a pH conforming to the slurry requirements listed above.

**CONSTRUCTION DETAILS**

**A. Prior Experience.** Submit proof and details of the following:

1. Two projects in the past 5 years where the Contractor or subcontractor performing the work has successfully installed drilled shafts similar to the size and type on this project.
2. The foreman for this work having supervised the successful installation of drilled shafts on at least two projects in the last 2 years.
3. The drill operators having had at least one year of experience installing drilled shafts with similar diameters and lengths, and in similar conditions.

Include details describing the equipment and methods used, any difficulties encountered and how they were overcome, and the results of any testing performed. Include the name and telephone number of someone for each project cited who can be contacted as a reference. Submit this information to the DCES for review, evaluation, and approval prior to submitting detailed information as stated in this specification under C. Submittals. The DCES will render a decision within 15 working days after the receipt of all information. A Contractor or subcontractor will not be permitted to install drilled shafts without this approval.

All approvals are subject to trial and satisfactory field performance. Departmental approval does not relieve the Contractor or subcontractor of his responsibility to satisfactorily complete the work detailed in the contract documents.

**B. General.** Provide the equipment and use procedures necessary to install drilled shafts at the locations and to the elevations shown on the contract plans, or as approved by the DCES.

Prior to preparing submittals, fully examine the existing site conditions and subsurface exploration logs.

The construction methods selected are directly related to the method of load transfer assumed in the project design. The type of drilling method, presence of permanent or interim casing, and clean out procedure all affect the drilled shaft load transfer behavior in skin friction and end bearing. Construct the drilled shafts using construction methods consistent with the load transfer mechanism shown on the contract plans.

ITEM 551.99495508 - DRILLED SHAFTSITEM 551.XXXXNNRR - DRILLED SHAFTS (LOW OVERHEAD CLEARANCE)ITEM 551.XXXXXXRR - TRIAL SHAFTS

**C. Submittals.** Submit the proposed procedure and equipment for installing drilled shafts to the DCES for review and approval prior to commencing the work. The DCES will render a decision within 15 working days, measured from the date of receipt of all pertinent information. The submittal should include, but not be limited to, the following information:

1. Method describing how the Contractor will progress through obstructions and rock.
2. Details and method describing how the Contractor will keep the hole for the drilled shaft open.
3. Drawings showing and details describing the proposed sequence of drilled shaft installation. Include the sequence for each shaft, the overall construction sequence, and the sequence of shaft construction in bents or groups.
4. Information describing the type of equipment to be used, including drill rig, cranes, drilling tools, final cleaning equipment, desanding equipment, slurry pumps, sampling equipment, tremie or concrete pumps, casing (including casing dimensions, material and splice details), etc.
5. Proposed method for cleaning out the shaft excavations. Include a description of how the Contractor will perform spoil removal and disposal.
6. Documentation that shows that the Contractor, Driller, and Foreman have the requisite prior experience in installing drilled shafts. Include the name and telephone number of someone for each project cited who can be contacted as a reference.
7. Shaft excavation methods, and final shaft dimensions.
8. If slurry is to be used, indicate the method proposed to mix, circulate, and desand the slurry. Include methods of slurry disposal in the submittal.
9. Method of reinforcement placement, including support and centralization type and methods.
10. Details and method of concrete placement, curing, and protection.
11. If the concrete mix is modified (i.e., retarders), include the new mix design, and test results of cylinder breaks from an independent laboratory. Also, include test results that demonstrate a slump loss versus time relationship.

ITEM 551.99495508 - DRILLED SHAFTSITEM 551.XXXXNNRR - DRILLED SHAFTS (LOW OVERHEAD CLEARANCE)ITEM 551.XXXXXXRR - TRIAL SHAFTS

12. A description and details of the slurry sampling tool to be used. Provide a tool capable of taking a slurry sample at a specific depth, without being contaminated by slurry from another depth.
13. When slurry is used, include an alternate procedure to be used which will secure the shaft in the event of slurry loss.
14. A description of the type of feet to be used to support the rebar cage in the drilled shaft.
15. An emergency construction joint procedure, to be used in the event when concrete placement for the drilled shaft is unexpectedly interrupted.
16. A procedure for filling voids between permanent or interim casing and the soil.
17. A description of equipment and methods to be used for drilled shaft inspection. The Inspector will use these methods and equipment to inspect the drilled shafts. The inspection program must be thorough enough to assure the Department that each drilled shaft meets the requirements contained in this specification.

Do not begin work until the DCES has issued all approvals.

**D. Construction Tolerances**

1. The allowable tolerance from plan location is 3 inches at the top of shaft elevation. Measure the as-drilled center of shaft using reference stakes offset from the shaft excavation.
2. The allowable tolerance from the required verticality is 2%. For battered shafts, the allowable tolerance from the required batter is 3%. This tolerance applies for the total length of shaft.
3. Cutoff elevation tolerance is plus 1 inch to minus 3 inches from the top of shaft elevation shown in the contract plans.
4. Rebar stick up elevation tolerance, after all shaft concrete has been placed, is plus or minus 2 inches from the stick up elevation shown in the contract plans.
5. The bottom of the shaft excavation is perpendicular to the axis of the shaft, within a tolerance of 3/4 inch per foot of shaft diameter.
6. Tolerances for the diameter are as follows:

ITEM 551.99495508 - DRILLED SHAFTSITEM 551.XXXXNNRR - DRILLED SHAFTS (LOW OVERHEAD CLEARANCE)ITEM 551.XXXXXXRR - TRIAL SHAFTS

- a. The minimum diameter of the drilled shaft is not more than 1 inch less than the diameter shown on the plans.
- b. The maximum shaft diameter is the diameter shown on the plans plus 6 inches. Verify the diameter for the entire length of the shaft using devices constructed of a rigid rod with four 90° offset rods.

Drilled shaft excavations and completed shafts not constructed within the required tolerances are unacceptable. Submit written correction procedures to the DCES through the Engineer for approval prior to correcting the deficiencies. The Contractor is responsible for correcting all unacceptable shaft excavations and completed shafts to the satisfaction of the Engineer at no cost to the State.

**E. Drilling and Excavation**

**1. General.** When drilled shafts are to be constructed in conjunction with embankment placement, construct shafts after placement of the fill, unless otherwise shown on the contract plans.

Drilled shaft excavations shall be staggered. The Contractor shall not begin the installation of a new drilled shaft within a clear distance of three diameters of a drilled shaft in progress. Drilled shafts shall be considered to be in progress from the time the excavation is started until 24 hours after the placement of concrete, and only when the concrete has reached a minimum compressive strength of 1500 psi.

The Contractor is responsible for reviewing all the subsurface and site information, and limitations, for the project.

**2. Trial Shafts.** Construct trial shaft(s) in accordance with the same methods submitted and approved for production drilled shaft installation. The purpose of the trial shaft installation is to demonstrate the adequacy of the Contractor's proposed methods and equipment for excavating the drilled shafts.

Construct trial shaft(s) in the area(s) designated on the contract plans, or as directed in writing by the Engineer. Progress the trial shaft(s) to the depth shown on the plans.

Progress the holes for the trial shaft(s) to the required elevation(s) in such a manner so as not to cause disturbance or settlement to the surrounding ground surface or adjacent structures.

If any disturbance occurs, halt operations and modify the equipment and/or procedures so as not to cause any further disturbance. Submit the modified drilled shaft installation

ITEM 551.99495508 - DRILLED SHAFTS

ITEM 551.XXXXNNRR - DRILLED SHAFTS (LOW OVERHEAD CLEARANCE)

ITEM 551.XXXXXXRR - TRIAL SHAFTS

procedure, in writing, to the DCES through the Engineer. After receiving approval from the DCES, repair any damage at no cost to the State, and proceed.

During drilling or excavation of the shaft(s), make frequent checks of the plumbness, alignment, and dimensions of the shaft. Correct any deviations exceeding the allowable tolerances using a procedure approved by the Engineer.

Clean the inside of the holes for the trial shaft(s) to the diameters and depths called for in the contract plans. Dispose of all excavated material in accordance with §203-3.08, Disposal of Surplus Excavated Materials.

After the trial shaft(s) have been excavated, inspected, and accepted, remove any casing used and backfill the hole(s) with unreinforced concrete. Cut off the completed trial shaft(s) 2 feet below finished grade. Restore the disturbed areas in the vicinity of the trial shaft(s) as nearly as possible to their original condition.

Failure of the Contractor to demonstrate the adequacy of methods and/or equipment to the Engineer constitutes reason for the Engineer to require alterations in methods and/or equipment. Construct any additional trial shaft(s) necessary to achieve satisfactory results at no additional cost to the State, as ordered by the Engineer.

**3. Drilled Shafts and Drilled Shafts (Low Overhead Clearance).** Excavate the holes and dispose of all excavated material for production drilled shafts using the same requirements, methods, procedures, and equipment used to satisfactorily excavate trial shaft(s), if trial shafts were used. Otherwise, use the same methods approved by the DCES. Do not alter equipment and/or methods without written permission by the DCES.

Where drilled shafts are located in open water areas, extend exterior casings (temporary, interim or permanent) from above the water elevation into the ground to protect the shaft concrete from water action during placement and curing of the concrete. Install the exterior casing in such a manner so as to produce a positive seal at the bottom of the casing and prevent piping of water or other materials into or from the shaft excavation.

Do not keep mineral slurry in the holes while drilling rock sockets, as it has a detrimental effect on the concrete-to-rock bond.

**4. Dry Construction Method.** This method will only be permitted at sites where all of the following apply:

- a. The groundwater table and site conditions are suitable to permit construction of the shaft in a relatively dry excavation.

ITEM 551.99495508 - DRILLED SHAFTSITEM 551.XXXXNNRR - DRILLED SHAFTS (LOW OVERHEAD CLEARANCE)ITEM 551.XXXXXXRR - TRIAL SHAFTS

- b. Where the sides and bottom of the shaft remain stable without any caving, sloughing, or swelling.
- c. Where the sides and bottom of the shaft can be visually inspected prior to placing the rebar cage and concrete.

A “relatively dry” excavation is one where the infiltration rate does not exceed 12 inches of water in one hour. Perform all operations so that less than 2 inches of water remain at the bottom of the excavation at the time of concreting.

**5. Wet Construction Method.** The wet construction method may be used at sites where a dry excavation cannot be maintained for placement of the shaft concrete. This procedure may require cleaning the slurry, and final cleaning of the excavation by means of a bailing bucket, air lift, submersible pump, or other devices.

Maintain a minimum slurry level of 4 feet above the highest groundwater level encountered on the project.

Provide surface casings to aid shaft alignment and position, and to prevent sloughing of the top of the shaft excavation, unless it is demonstrated to the satisfaction of the Engineer that the surface casing is not required.

**6. Temporary Casing Construction Method.** Use this method at sites where the stability of the excavated hole and/or the effects of groundwater cannot be controlled by other means. Install temporary casing using rotating, oscillating, driving, or vibratory methods unless methods are required or limited in the contract plans. Install temporary casing in advance of the excavation to the lower limits of the caving material.

Remove temporary casing while the concrete is still workable. As the casing is withdrawn, maintain a 5 foot minimum head of fresh concrete in the casing so that all fluid trapped behind the casing is displaced upward without contaminating the shaft concrete. Extract the casing at a slow, uniform rate, with the pull in line with the axis of the casing.

**7. Interim Casing Construction Method.** Use this method at sites where the stability of the excavated hole and/or the effects of groundwater cannot be controlled by other means. Install interim casing using rotating, oscillating, driving, or vibratory methods unless methods are required or limited in the contract plans. If full penetration cannot be attained, the Contractor may either excavate material within the embedded portion of the casing, or excavate a pilot hole ahead of the casing until the casing reaches the desired penetration. Progress the pilot hole centered in the shaft, and no larger than one-half the diameter of the shaft.



ITEM 551.99495508 - DRILLED SHAFTSITEM 551.XXXXNNRR - DRILLED SHAFTS (LOW OVERHEAD CLEARANCE)ITEM 551.XXXXXXRR - TRIAL SHAFTS

Progress the interim casing so that the casing maintains intimate contact with the soil.

**8. Permanent Casing Construction Method.** This method generally consists of installing the permanent casing to a prescribed elevation prior to excavating. Install permanent casing using rotating, oscillating, driving, or vibratory methods unless methods are required or limited in the contract plans. If full penetration cannot be attained, the Contractor may either excavate material within the embedded portion of the casing, or excavate a pilot hole ahead of the casing until the casing reaches the desired penetration. Progress the pilot hole centered in the shaft, and no larger than one-half the diameter of the shaft.

Progress the permanent casing so that the casing maintains intimate contact with the soil.

**9. Slurry.** Pre-mix the slurry, and allow adequate time for hydration prior to introduction into the shaft excavation. Provide adequate slurry tanks when specified or required by the Engineer. Do not mix slurry in the hole for the drilled shaft. Slurry pits will not be allowed without written permission from the Engineer.

Provide adequate desanding equipment where required for slurry operations. Take appropriate steps to prevent slurry from "setting up" in the shaft excavation, such as agitation, circulation, and adjusting the properties of the slurry. Do not let the slurry sit unagitated for more than 4 hours. If the slurry is in the hole, unagitated for more than 4 hours, scrape the sides to remove the filter cake before proceeding with the excavation.

Perform control tests on the slurry to determine density, viscosity, and pH before and during shaft excavation to establish a consistent working pattern.

Let the slurry sit for 30 minutes prior to placing the rebar cage and shaft concrete, to allow the excess sand to settle out. Remove any sand and spoil that has accumulated on the bottom.

Immediately prior to placing shaft concrete, take slurry samples from the bottom and 10 feet from the bottom of the drilled shaft excavation using an approved slurry sampling tool. Remove any heavily contaminated slurry and spoil that has accumulated at the bottom of the shaft. Be sure the slurry is within the specification requirements immediately before concrete placement. If it is not, clean the hole and flush it with fresh slurry until subsequent tests reveal that the slurry is within the tolerances contained in this specification.

**10. Excavation Inspection.** Provide equipment for checking the dimensions and alignment of each shaft excavation. Determine the dimensions and alignment under the direction of the Engineer. Measure the final shaft depth after cleaning.

ITEM 551.99495508 - DRILLED SHAFTSITEM 551.XXXXNNRR - DRILLED SHAFTS (LOW OVERHEAD CLEARANCE)ITEM 551.XXXXXRR - TRIAL SHAFTS

**F. Rock Sockets.** Progress rock sockets to the depth, diameter and elevations shown on the contract plans. If the top of socket elevation varies from that shown on the contract plans by more than 3 feet, notify the Engineer who will contact the DCES for a redesign.

**G. Quality Assurance Equipment Installation.** Install any quality assurance equipment prior to concreting the hole. This includes any pipes for crosshole sonic logging, and any other instrumentation.

**H. Rebar and Concrete Placement, and Temporary Casing Removal.** Place reinforcing and concrete within 2 hours after the drilled shaft has been excavated, cleaned out, inspected, and accepted by the Engineer.

Completely assemble the reinforcing steel cage, including longitudinal bars, ties, cage stiffener bars, centralizers, concrete feet, and other necessary appurtenances.

Place and center the rebar cage in the hole for the drilled shaft prior to concreting the shaft. Install centralizers at the bottom and along the axial length of the steel reinforcing at sufficient spacing to maintain proper concrete cover (minimum 3 inches), but at a spacing that does not exceed 10 feet. Place approved cylindrical feet (bottom supports) at the bottom of the cage to ensure that the bottom of the cage is maintained at the proper distance above the base.

Immediately prior to concreting, take depth measurements with a weighted tape. Clean out the hole if there is more than 1/2 inch of debris on the bottom for end-bearing shafts, and 2 inches of debris for side-friction shafts. If drilling mud is being used to support the hole, perform slurry contamination tests in accordance with the American Petroleum Institute's (API's) test, Standard Procedure for Field Testing Drilling Fluids, API RP-13B. Adjust the slurry to meet contract specification requirements.

Check the elevation of the top of the rebar cage before and after placing the shaft concrete. If the rebar cage is not maintained within the specified tolerances, make corrections to the satisfaction of the Engineer. Do not construct additional shafts until the procedure has been modified, to the satisfaction of the Engineer.

For drilled shafts constructed using the Dry Construction Method, place concrete by tremie, pumping, or free-fall. When placing concrete by free-fall, direct the concrete so that it does not strike the sides of the excavation or the reinforcing cage.

For all other drilled shafts, place concrete in accordance with the requirements of §555-3.04 Handling and Placing Concrete, and §555-3.05 Depositing Structural Concrete Under Water, except place the concrete using the tremie method, by pumping, or by another method approved

**ITEM 551.99495508 - DRILLED SHAFTS****ITEM 551.XXXXNNRR - DRILLED SHAFTS (LOW OVERHEAD CLEARANCE)****ITEM 551.XXXXXRR - TRIAL SHAFTS**

by the Engineer. Do not place concrete using free fall. Place concrete in one continuous operation to the top of the shaft.

For shafts less than 8 feet in diameter, conduct operations so that the elapsed time from the beginning of concrete placement in the shaft to the completion of placement does not exceed 2 hours, unless an approved shaft concrete retarder is used. Proceed so that the concrete mix remains in a workable plastic state throughout the 2 hour placement limit.

When the top of shaft elevation is above ground, form the portion above ground with a removable form, or with permanent casing when specified.

Temporary casings which become bound during shaft construction and cannot be practically removed are unacceptable unless the Contractor can prove to the Department's satisfaction that the casing will not adversely affect the performance of the drilled shaft. Submit a procedure for correcting this to the Engineer for approval before conducting further work on the shaft.

Do not conduct any construction operations which may cause soil movement immediately adjacent (within 5 feet) to the drilled shaft for 24 hours after completing the shaft concrete pour.

Fill any voids between permanent or interim casing and the soil with concrete at least 48 hours after concreting the shaft.

**Pumped Concrete.** All provisions of Section 555-3.05 shall apply.

**I. Quality Assurance.** Provide Quality Assurance as required on the contract plans.

In the event the Quality Assurance testing indicates voids or discontinuities in the concrete, which, as determined by the DCES, indicate that the drilled shaft is not structurally adequate, submit a written proposal for correcting the deficiencies and steps to prevent them from recurring to the Engineer for approval by the DCES. Do not continue working on the drilled shaft in question, or any other drilled shaft, until the DCES grants approval. Perform any additional QA verification work (such as full depth shaft coring) and/or corrective work necessary as a result of shaft defects at no additional cost to the State.

The Engineer will reject any concrete represented by a 28-day cylinder set with an average compressive strength less than 5,000 psi, or an individual cylinder with a compressive strength less than 4,500 psi. Proposed repairs require Deputy Chief Engineer, Structures approval.

**METHOD OF MEASUREMENT**

ITEM 551.99495508 - DRILLED SHAFTSITEM 551.XXXXNNRR - DRILLED SHAFTS (LOW OVERHEAD CLEARANCE)ITEM 551.XXXXXXRR - TRIAL SHAFTS

A. **Drilled Shafts and Drilled Shafts (Low Overhead Clearance).** This work will be measured as the number of feet of drilled shaft furnished, installed, and accepted, measured between the cut-off elevation and the tip elevation shown on the contract plans or as changed, in writing, by the Engineer.

B. **Trial Shafts.** This work will be measured as the number of trial shafts installed and accepted.

**BASIS OF PAYMENT**

The unit price bid for each item shall include the cost of furnishing all labor, material, and any equipment necessary to complete the work not included in the applicable pay item for furnishing equipment for installing drilled shafts. This includes progressing the hole through all soil, rock, and obstructions, placing concrete and reinforcing steel in the drilled shaft, installing temporary, interim and/or permanent casing, and supplying the methods and equipment for drilled shaft inspection.

Note: The "NN" in the Pay Item denotes a serialized pay item. Refer to §101-02 Definition of Terms. The State will make payment for each specified diameter of drilled shaft.

Quality Assurance, including any load testing and non-destructive testing (i.e. crosshole sonic logging), will be paid for under separate items. There will be no payment for additional quality assurance testing (i.e. coring) that is required to verify or quantify anomalies detected by the initial QA testing.

There will be no extra payment for leaving bound temporary casing, deemed acceptable to the Engineer, in place.

Include the cost for furnishing equipment to install Trial Shafts in the applicable pay item for furnishing equipment for installing drilled shafts.

There will be no separate payment for equipment changes to install trial shafts and production drilled shafts.

Payment will be made under:

<b>Item No.</b>	<b>Item</b>	<b>Pay Unit</b>
551.9949NN17	Drilled Shafts	Foot

ITEM 551.99495508 - DRILLED SHAFTS

ITEM 551.XXXXNNRR - DRILLED SHAFTS (LOW OVERHEAD CLEARANCE)

ITEM 551.XXXXXXRR - TRIAL SHAFTS

551.9950NN17	Drilled Shafts (Low Overhead Clearance)	Foot
551.98020017	Trial Shafts	Each

ITEM 555.04400008 – CONCRETE FOR STRUCTURES DESIGNATED BY  
COMPRESSIVE STRENGTH

**DESCRIPTION**

Furnish and place Portland cement concrete with a minimum compressive strength of 5,000 psi where specified on the Plans.

**MATERIALS**

The provisions of §555-2 shall apply, except as modified herein.

1. Use materials meeting the requirements of 501-2.02
2. Design a concrete mixture proportioned according to the American Concrete Institute Manual of Concrete Practice, ACI 211.1, Standard Practice for Selecting Proportions for Normal, Heavyweight, and Mass Concrete. Produce a homogeneous mixture of cement, pozzolan (fly ash or GGBFS), microsilica, fine aggregate, coarse aggregate, air entraining agent, water-reducing and set-retarding admixture, and water as designed.
3. The designed concrete mixture shall meet the following requirements:
  - a. Strength - 28 day minimum compressive strength – 5,000 psi.
  - b. Slump – 3” to 5”.
  - c. Entrained Air - 5 to 8%.
  - d. Water/Total Cementitious Material Ratio - 0.42 maximum.
  - e. Use Type I, I/II, II or Type SF cement. Use a total cementitious content of 500 #/CY to 650 #/CY. Use 15%-20% pozzolan (fly ash or GGBFS) and 6-10% microsilica by weight of cementitious materials. If Type SF Blended cement is used, the separate addition of microsilica is not required.
4. Perform mix development testing in accordance with ASTM C143, C231, C192 and C39, to assure all performance criteria can be achieved during production and placement.
5. At least 1 month prior to the start of any concrete placement, provide a copy of the proposed mixture design(s) and trial batch test results to the Director, Materials Bureau, submitted through the Regional Materials Engineer, for evaluation. Submit sufficient data to permit the Director to offer an informed evaluation. Include at least the following:
  - Concrete mix proportions.

**ITEM 555.04400008 – CONCRETE FOR STRUCTURES DESIGNATED BY  
COMPRESSIVE STRENGTH**

- Material sources. Also include fineness modulus and specific gravity for all aggregates.
- Air content of plastic concrete.
- Slump of plastic concrete.
- Compressive strength at 7, 14, 28, and 56 days, and at any other age tested or deemed necessary.

Do not interpret having a valid mixture design as approval of the mixture. Also, resubmit any proposed mixture design change to the Director, Materials Bureau, for evaluation. Multiple mixture designs may be used to address performance and placement issues as deemed necessary by the Contractor. Submit each mixture for evaluation, as indicated above, prior to use.

**CONSTRUCTION DETAILS**

The provisions of §555-3 shall apply, except as modified herein:

Prior to placing any concrete required by this specification, perform a trial placement of at least 8 cubic yards using the proposed mixture design(s). This trial placement(s), when approved by the Engineer, may be incorporated into the project as a substitute for the placement of another Class of concrete shown on the plans. The Department will make and test concrete cylinders from the trial placement(s) to verify laboratory test results.

The loading limitations of §555-3.10 apply, except that concrete cylinder sets designated for early loading must attain an average compression strength of 5000 psi, or greater, with no individual cylinder less than 4,500 psi.

Make any repairs as per the provisions of §555-3.13, Damaged or Defective Concrete. The Engineer will reject any concrete represented by a 28-day cylinder set with an average compressive strength less than 5,000 psi, or an individual cylinder with a compressive strength less than 4,500 psi. Proposed repairs require Deputy Chief Engineer, Structures approval.

**METHOD OF MEASUREMENT**

The provisions of §555-4 shall apply.

**BASIS OF PAYMENT**

**526**

**D262100**

**ITEM 555.04400008 - CONCRETE FOR STRUCTURES DESIGNATED BY  
COMPRESSIVE STRENGTH**

The provisions of §555-5 shall apply, except also include the cost of the mixture design, laboratory testing, and trial placement for mixture acceptance in the unit bid price per cubic yard.



**DESCRIPTION**

This work shall consist of furnishing and installing precast concrete sleeper slabs in accordance with the contract documents and as directed by the Engineer.

**MATERIALS**

All materials shall conform to the NYSDOT Prestressed Concrete Construction Manual (PCCM).

A. Concrete

28 Day Compressive Strength	5,000 psi	(Minimum)
Lifting Strength	3,000 psi	(Minimum)
Aggregates	§ 501-2.02.B.1	
Water	§ 712-01	

B. Bar Reinforcement

Bar Reinforcement, Grade 60	§ 709-01	
Epoxy Coated Bar Reinforcement	§ 709-04	

C. Polytetrafluoroethylene (PTFE) Sheet:

Polytetrafluoroethylene (PTFE) sheet shall be manufactured from pure virgin (not reprocessed) unfilled TFE resin or from TFE resin uniformly blended with either 15% glass fiber or 25% carbon (maximum filler, by percent weight). The resin shall satisfy the requirements of ASTM D4894.

Bonded PTFE sheet shall be etched on its bonding side. Unless otherwise noted on the Plans, PTFE sheet shall have a minimum thickness of 1/16" after compression. The mating sliding surface of filled PTFE sheet in contact with the stainless steel slide surface shall be polished or burnished to ensure smooth and low-friction movement of the bearing.

Finished PTFE sheet and strip shall be resistant to all acids, alkalis and petroleum products, stable at temperatures from -360° to 500°F, non-flammable, non-absorbing of water and shall conform to the following minimum physical requirements:

ASTM Test	Unfilled	Filled
-----------	----------	--------

ITEM 557.20000008 - PRECAST CONCRETE SLEEPER SLAB

Physical Property	Method		15% Glass	25% Carbon
Ultimate Tensile Strength, psi	D638	2800	2000	1300
Ultimate Elongation, %	D638	200	150	75
Specific Gravity	D792	2.13	2.18	2.05

**CONSTRUCTION DETAILS****A. Drawings**

Shop drawings, installation drawings and erection drawings shall be prepared and submitted as per the requirements of the PCCM.

The submitted drawings shall include details of lifting, handling and storage of sleeper slabs in the production facility and their transportation, handling, and storage at the construction site. The proposed handling and lifting shall be such that the maximum tensile stress in concrete due to handling and erection loads shall not exceed  $0.24(f'_{ci})^{1/2}$ , where  $f'_{ci}$  is the concrete compressive strength at the time being considered. Calculations showing actual concrete stresses based upon the proposed support locations and expected dynamic loading of the diaphragm during handling, storage and transportation shall be submitted along with the drawings. Dynamic load shall take into account inertial effects anticipated during handling and transport. These drawings and calculations shall be stamped and signed by a Professional Engineer.

**B. Fabrication of Precast Sleeper Slabs**

Fabrication shall meet the requirements of the PCCM and the following:

1. Fabrication Tolerances:
  - a. Width (longitudinal direction of the bridge): +3/4, -3/16 in.
  - b. Length (transverse direction of the bridge): +1, -1 in.
  - c. Depth (overall): +9/16, -3/16 in.
  - d. Reinforcement cover: +3/16, -0 in.
2. Placing Concrete, Curing, and Finishing
 

All requirements stipulated in the PCCM shall apply.
3. Shipping and Handling of Precast Panels

**ITEM 557.20000008 - PRECAST CONCRETE SLEEPER SLAB**

Shipping and handling shall meet the requirements in the PCCM and as stated on the approved drawings.

- 4. The PTFE sheet may be bonded to the top surface of the sleeper slab footing using an epoxy resin adhesive under controlled conditions in accordance with the instructions of the adhesive manufacturer.

**C. Sampling and Testing**

The manufacturer shall furnish the required number of samples to perform the tests as required. A minimum of thirty (30) days shall be allowed for the Department’s inspection, sampling and testing procedures.

The Department’s representative shall select, at random, the required samples of the PTFE materials for testing by the Materials Bureau. All samples shall be taken in accordance with the Department’s written instructions.

The testing of the samples shall be as follows:

TEST	SAMPLES TESTED
Physical Properties of PTFE Sheet	One 10 x 15 inch sheet of PTFE per lot (Note 1.)

Note 1: The Materials Bureau will perform this testing. At the time of inspection, single sheets of PTFE shall be submitted by the Department’s representative. All submitted sample sheets shall be certified by the Manufacturer as having been taken from the same batch of material as was used in the actual production PTFE sheeting.

PTFE sheeting shall be considered for acceptance in project lot quantities, or portions thereof, at the manufacturing site in accordance with the procedural directives of the Materials Bureau.

**D. Installation Requirements**

- 1. Installation shall be according to the installation drawings approved by the DCES and meeting the requirements of this specification and erection drawing approved by the Engineer.

**METHOD OF MEASUREMENT**

This work will be measured as the number of feet (horizontal length end to end, as shown on the plans) of sleeper slab satisfactorily furnished and installed per the Contract Documents.

**BASIS OF PAYMENT**

The unit price bid shall include the cost of furnishing all labor, materials, and equipment necessary to satisfactorily complete the work, including fabrication, storage, protection, transporting, unloading and installation of all precast sleeper slabs.

**ITEM 557.21010016 - FIELD CAST JOINTS BETWEEN PRECAST CONCRETE UNITS****SCOPE**

This specification covers field casting of joints for precast concrete units, including batching, transportation, casting and curing.

**MATERIAL**

Ultra High Performance Concrete (UHPC)

The material shall be Ultra High Performance Concrete, with all components supplied by one manufacturer. Materials commonly used in UHPC follow:

Fine aggregate

Cementitious material

Super plasticizer

Accelerator

Steel Fibers, deformed, specifically made for steel reinforcement

Water shall meet the requirements of §712-01.

UHPC material shall meet the following, 28 days unless otherwise noted:

Minimum Compressive Strength (ASTM C39)

Heat-Treated\*  $\geq 25$  ksi

Not Heat-Treated  $\geq 21$  ksi

Not Heat-Treated 4 day  $\geq 12$  ksi

Prism Flexural Tensile toughness (ASTM C1018; 10 in. span)  $I_{30} \geq 48$

Long-Term Shrinkage (ASTM C157; initial reading after set)  $\leq 766$  microstrain

Chloride Ion Penetrability (ASTM C1202)  $\leq 250$  coulombs

Chloride Ion Penetrability (AASHTO T259; 1/5 in. depth)  $< 0.07$  oz/ft<sup>3</sup>

Scaling Resistance (ASTM C672)  $y < 3$

Abrasion Resistance (ASTM C944 2x weight; ground surface)  $< 0.025$  oz. lost

Freeze-Thaw Resistance (ASTM C666A; 600 cycles) RDM  $> 96\%$

Alkali-Silica Reaction (ASTM C1260; tested for 28 days) Innocuous

\* Heat-Treated - According to manufacturer's recommendation, temperature not to exceed 250°F.

Casting and testing must include the following:

A minimum of 12 cylinders 3 in. X 6 in. shall be cast.

All cylinders shall be cured using the same method of curing proposed to be used in the field. The temperature during curing shall be within 18°F of the low end of the proposed temperature range for curing in the field. 2 cylinders shall be tested each testing day. Testing times are at 4 days, 7 days, 14 days, and 28 days. The compressive strength shall be measured by ASTM C39 and shall meet 12 ksi minimum at 4 days and 21 ksi minimum at 28 days. Only a UHPC mix design that passes these tests may be used to form the joint.

Cast 6 additional cylinders 12 in. diameter and 7 ½ in. deep. Each cylinder shall have one 32 in. long epoxy-coated reinforcing bar cast in the center of the circular face. The axis of the bar shall be perpendicular to the formed surface. 3 of the bars shall be #6 bars embedded 5 inches deep and 3 of the bars shall be #4 bars embedded 3 inches deep. These cylinders will be kept wet for four days then delivered to the Materials Bureau for testing according to Test Method No. NY 701-14 E. Contact the Materials Bureau prior to casting for specific instructions on preparing the test

**ITEM 557.21010016 - FIELD CAST JOINTS BETWEEN PRECAST CONCRETE UNITS**

specimens. The test will be performed as soon as practical after the corresponding samples reach 12 ksi.

This test is a pullout test. The samples pass if the bars yield without the UHPC failing and without the bars pulling out of the UHPC.

Results of all the tests above, conducted by an AASHTO accredited testing lab shall be submitted to the DCES for review and approval a minimum of 60 days prior to the use of UHPC in the field. Provide to the DCES a list of bridge projects in which the proposed UHPC material has been used as joint fill between precast concrete elements (within or outside the USA). The DCES reserves the right to reject a proposed UHPC material which lacks a proven track record in precast concrete joint filling in bridge applications.

**CONSTRUCTION**

**Pre-Pour Meeting:** Prior to the initial placement of the UHPC, the contractor shall arrange for an on site meeting with the UHPC representative. The contractor's staff and the NYSDOT Engineer and Inspectors shall attend the site meeting. The objective of the meeting will be to clearly outline the procedures for mixing, transporting, finishing and curing of the UHPC material.

The contractor shall arrange for a representative of the UHPC supplier to be on site during the placement of the joints. The representative shall be knowledgeable in the supply, mixing, delivery, placement, and curing of the UHPC material.

**Storage:** The contractor shall assure the proper storage of premix, fibers and additives as required by the supplier's specifications in order to protect materials against loss of physical and mechanical properties.

**Form Work, Batching and Curing**

The design and fabrication of forms shall follow approved installation drawings and shall follow the recommendations of the manufacturer. All the forms for UHPC shall be constructed from plywood. The forms shall be coated to prevent absorption of water.

The contractor shall follow the batching sequence as specified by the supplier and approved by the DCES. The surface of the UHPC field joints shall be filled flush with the precast panels to within a tolerance of plus 1/16 in. and minus 0 in.

The UHPC in the form shall be cured according to Manufacturer's recommendations to attain the required strength shown on the contract documents. A continuous curing temperature of a minimum of 60°F is recommended.

**Quality Control**

The contractor shall measure the slump flow on each batch of UHPC. The slump flow will be conducted using a mini-slump cone. The flow for each batch shall be between 7 in. and 10in. The slump flow for each batch shall be recorded in the QA/QC log. A copy of the log shall be given to the Engineer.

**ITEM 557.21010016 - FIELD CAST JOINTS BETWEEN PRECAST CONCRETE UNITS**

The contractor shall take four sets of compressive strength test samples for each day of placement. Each set consists of 3 cylinders 3in. X 6in. All sets shall be cured in an environment similar to the material they represent.

The following tests shall be performed:

Compressive strengths shall be according to ASTM C 39. The timing of the testing shall be as required by the contract documents. The second set shall be tested at 28 days. The third set will be sent to the Materials Bureau between the 4<sup>th</sup> day and the 14<sup>th</sup> day. The fourth set shall be treated as a reserve set.

**MEASUREMENT FOR PAYMENT**

Measurement will be by length of UHPC joints placed in feet. The length of in-place UHPC shall be calculated to the nearest foot.

**BASIS OF PAYMENT**

Payment at the contract price for the above item shall be full compensation for all labor, equipment, and material to do the work.

**DESCRIPTION**

This work shall consist of furnishing and installing precast concrete approach slabs in accordance with the contract documents and as directed by the Engineer.

**MATERIALS**

All materials shall conform to the NYSDOT Prestressed Concrete Construction Manual (PCCM).

## A. Concrete

28 Day Compressive Strength	5,000 psi	(Minimum)
Lifting Strength	3,000 psi	(Minimum)
Water	§ 712-01	
Aggregates	§ 501-2.02.B.1, § 703-02	

## B. Bar Reinforcement

Epoxy Coated Bar Reinforcement	§ 709-04
--------------------------------	----------

## C. Stainless Steel

Stainless steel shall conform to the requirements of ASTM A167, or ASTM A240, Type 304. Stainless steel in contact with PTFE shall be polished to a No. 8, bright mirror finish. The minimum thickness of the stainless steel shall be as detailed on the plans.

Shear studs shall conform to the requirements of ASTM A276, Type 304 or 316.

**CONSTRUCTION DETAILS**

## A. Drawings

Shop drawings, installation drawings and erection drawings shall be prepared and submitted as per the requirements of the PCCM.

The submitted drawings shall include details of lifting, handling and storage of beams in the production facility and their transportation, handling, and storage at the construction site. The proposed handling and lifting shall be such that the maximum tensile stress in concrete



ITEM 557.6404NN08 - PRECAST CONCRETE APPROACH SLAB

due to handling and erection loads shall not exceed  $0.24(f_{ci})^{1/2}$ , where  $f_{ci}$  is the concrete compressive strength at the time being considered. Calculations showing actual concrete stresses based upon the proposed support locations and expected dynamic loading of the panels during handling, storage and transportation shall be submitted along with the drawings. Dynamic load shall take into account inertial effects anticipated during handling and transport. These drawings and calculations shall be stamped and signed by a Professional Engineer.

B. Fabrication of Precast Concrete Panels

Fabrication shall meet the requirements of the PCCM and the following:

1. Fabrication Tolerances:

- a. Width (transverse direction of the bridge): +1/8, -1/8 in.
- b. Length (longitudinal direction of the bridge): +1/8, -1/8 in.
- c. Depth (overall): +1/8, -0 in.
- d. Reinforcement cover: +3/16, -0 in.
- e. Bulkhead alignment (deviation from square or designated skew):
  - Vertical 1/4 in.
  - Horizontal 1/4 in.
- f. Horizontal alignment (deviation from straight line parallel to centerline of unit):
  - 1/4 in. for lengths up to 40 feet, inclusive
  - 3/8 in. for lengths from 40 feet to 60 feet, inclusive
  - 1/2 in. for lengths greater than 60 feet

2. Placing Concrete, Curing, and Finishing

All requirements stipulated in the PCCM shall apply and the following:

- a. After curing, all form release material and all other forming material adhering to the shear keyway and block out concrete shall be removed. Shear key faces shall be roughened and blast cleaned per the PCCM.
- b. Surfaces shall be finished to a surface tolerance of 1/4 in. in 10 ft. The surface tolerance shall be verified by the Engineer with an approved straightedge furnished by the Contractor not less than 10 ft. long. Surface irregularities in

ITEM 557.6404NN08 - PRECAST CONCRETE APPROACH SLAB

either the longitudinal or transverse directions shall be corrected in a manner acceptable to the Engineer.

- c. Hand screeds or bullfloats, if used, shall be magnesium and 10 in., or more, in width. Care shall be taken not to overwork the concrete surface during any finishing operation.
  - d. After finishing, the surface shall be given a suitable texture with an artificial turf drag made of molded polyethylene with approximately 53,500 synthetic turf blades per square yard, each approximately ½ in. long. The artificial turf drag shall be of a type and brand appearing on the Department's Approved list. Texturing shall be done prior to the beginning of curing operations. Only one pass of the turf drag over the finished area will be permitted.
  - e. Penetrating sealers shall not be applied to surfaces which are to receive a spray-applied waterproof membrane.
3. Stainless Steel Sliding Surfaces

Sliding surfaces shall be stainless steel plate with stainless steel studs, welded in accordance with AWS D1.6, current edition, and cast into the end diaphragm slide shoes.

4. Shipping and Handling of Precast Panels

Shipping and handling shall meet the requirements in the PCCM and as stated on the approved drawings. The finished surface of the slide shoes shall be protected from damage during all phases of handling.

5. Loading of Panels

Equipment weighing more than 2500 pounds shall not be permitted on the precast beams between the initial set of the longitudinal closure pour and the time that test cylinders demonstrate the closure pour concrete has reached a minimum strength of 10 ksi.

C. Pre-Installation Meeting

A pre-placement meeting shall be held 7 to 14 calendar days prior to the planned start of panel installation. The Contractor shall arrange for an onsite meeting with representatives from the UHPC and the precast system suppliers. The Contractor's staff and the NYSDOT Engineer and Inspectors shall attend the site meeting. The objective of the meeting will be to clearly outline the procedures for placing and leveling the precast concrete panels.

D. Installation Requirements

**ITEM 557.6404NN08 - PRECAST CONCRETE APPROACH SLAB**

1. Prior to installing panels, the supporting surfaces in contact with the panels or field placed concrete shall be cleaned.
2. Adjust slab end elevations to achieve maximum differential elevation of ¼ in. between edges of adjacent panels along the length of all longitudinal joints.
3. Install cast-in-place concrete closure pours as shown in the Contract Plans, with costs paid for under Item 557.XXXXXXRR, Field Cast Joints Between Precast Concrete Units.

**METHOD OF MEASUREMENT**

This work will be measured as the number of square feet of precast approach slab panels satisfactorily furnished and placed in accordance with the plans and specifications.

**BASIS OF PAYMENT**

The unit price bid shall include the cost of furnishing all labor, materials, and equipment necessary to satisfactorily complete the work, including fabrication, storage, protection, transporting, unloading and installation of all precast approach slab panels. The cost shall include fabrication, installation and protection of the stainless steel sliding surfaces, but the cost of bearings shall be paid for under their appropriate item. This work does not include field placement of reinforcement or casting of longitudinal closure pours.

*Payment will be made under:*

<b>Item No.</b>	<b>Item</b>	<b>Pay Unit</b>
557.6404NN08	Precast Concrete Approach Slab, Type 1	Square Foot
557.6404NN08	Precast Concrete Approach Slab, Type 2	Square Foot

*NN = Type Designation (1 or 2, as shown on the plans)*

**DESCRIPTION**

This work shall consist of furnishing and installing Northeast Extreme Tee - NEXT D Beam in accordance with the contract documents and as directed by the Engineer.

The Contractor shall notify the Deputy Chief Engineer, Structures (DCES) of the name and address of the fabricator of all prestressed concrete units (structural) and the fabricator of any steel diaphragms for the prestressed concrete units in accordance with §106-01 Sources of Supply.

**MATERIALS**

All materials shall conform to Section 563-2 of the Standard Specifications, and the following:

- |                                      |                          |
|--------------------------------------|--------------------------|
| A. Epoxy Coated Bar Reinforcement    | § 709-04                 |
| B. Stainless Steel Bar Reinforcement | § 709-13                 |
| C. Water                             | § 712-01                 |
| D. Aggregates                        | § 501-2.02.B.1, § 703-02 |

**CONSTRUCTION DETAILS**

A. The requirements of the PCCM shall apply.

B. Drawings

Shop drawings, installation drawings and erection drawings shall be prepared and submitted per the requirements of the PCCM.

The submitted drawings shall include details of lifting, handling and storage of beams in the production facility and their transportation, handling, and storage at the construction site. Lifting holes will not be permitted. The proposed handling and lifting shall be such that the maximum tensile stress in concrete due to handling and erection loads shall not exceed  $0.24(f_{ci})^{1/2}$ , where  $f_{ci}$  is the concrete compressive strength at the time being considered. Calculations showing actual concrete stresses based upon the proposed support locations and expected dynamic loading of the beams during handling, storage and transportation shall be submitted along with the drawings. Dynamic load shall take into account inertial effects anticipated during handling and transport, considering support/lifting point locations

ITEM 563.0001NN08 - NORTHEAST EXTREME TEE - NEXT BEAM TYPE D

as well as vertical and lateral bending. These drawings and calculations shall be stamped and signed by a Professional Engineer.

C. Fabrication of Northeast Extreme Tee – NEXT D Beam

Fabrication shall meet the requirements of the PCCM and the following:

1. Fabrication Tolerances:

- a. Width (transverse direction of the bridge): +1/8, -1/8 in.
- b. Length (longitudinal direction of the bridge): +1/8, -1/8 in.
- c. Depth (overall): +9/16, -3/16 in.
- d. Reinforcement cover: +3/16, -0 in.
- e. Strand Position: ±3/16 in.
- f. Bulkhead alignment (deviation from square or designated skew):
  - Vertical 1/4 in.
  - Horizontal 1/4 in.

g. Horizontal alignment (deviation from straight line parallel to centerline of unit):

- 1/4 in. for lengths up to 40 feet, inclusive
- 3/8 in. for lengths from 40 feet to 60 feet, inclusive
- 1/2 in. for lengths greater than 60 feet

2. Placing Concrete, Curing, and Finishing

All requirements stipulated in the PCCM shall apply and the following:

- a. After curing, all form release material and all other forming material adhering to the shear keyway and block out concrete shall be removed. Shear key faces shall be roughened and blast cleaned per the PCCM.
- b. The top surface of the top flange shall be finished to a surface tolerance of 1/4 in. in 10 ft. The surface tolerance shall be verified by the Engineer with an approved straightedge furnished by the Contractor not less than 10 ft. long. Surface irregularities in either the longitudinal or transverse directions shall be corrected in a manner acceptable to the Engineer.

- c. Hand screeds or bullfloats, if used, shall be magnesium and 10 in., or more, in width. Care shall be taken not to overwork the concrete surface during any finishing operation.
  - d. After finishing, the surface shall be given a suitable texture with an artificial turf drag made of molded polyethylene with approximately 53,500 synthetic turf blades per square yard, each approximately ½ in. long. The artificial turf drag shall be of a type and brand appearing on the Department's Approved list. Texturing shall be done prior to the beginning of curing operations. Only one pass of the turf drag over the finished area will be permitted.
  - e. Penetrating sealers shall not be applied to surfaces which are to receive a spray-applied waterproof membrane.
3. Shipping and Handling of Northeast Extreme Tee – NEXT D Beam

Shipping and handling shall meet the requirements in the PCCM and as stated on the approved drawings.

4. Loading of Beams

Equipment weighing more than 2500 pounds shall not be permitted on the precast beams between the initial set of the longitudinal closure pour and the time that test cylinders demonstrate the closure pour concrete has reached a minimum strength of 10 ksi.

#### D. Pre-Installation Meeting

A pre-placement meeting shall be held 7 to 14 calendar days prior to the planned start of NEXT Beam installation. The Contractor shall arrange for an onsite meeting with representatives from the UHPC and the precast system suppliers. The Contractor's staff and the NYSDOT Engineer and Inspectors shall attend the site meeting. The objective of the meeting will be to clearly outline the procedures for placing and leveling the precast concrete beams.

#### E. Installation Requirements

1. Prior to installing NEXT D Beams, the supporting surfaces in contact with the beams or field placed concrete shall be cleaned.
2. Place bearings in accordance with the Contract Plans and Specifications, with costs paid for under Item 565.1922, Type E.L. Bearing.

ITEM 563.0001NN08 - NORTHEAST EXTREME TEE - NEXT BEAM TYPE D

- 3. Adjust beam end elevations with stainless steel or neoprene shims to provide maximum differential elevation of ¼ in. between flange tips of adjacent beams along the length of all longitudinal joints.

Grinding or other means of achieving the flange alignment tolerance is not permitted without approval of the Engineer. If methods for achieving alignment other than shimming are approved, they shall be performed at no additional cost to the State.

- 4. Install cast-in-place concrete closure pours as shown in the Contract Plans, with costs paid for under Item 557. 21010016, Field Cast Joints Between Precast Concrete Units.

**METHOD OF MEASUREMENT**

This work will be measured as the number of feet (horizontal length center-to-center of bearings, as shown on the plans) of Northeast Extreme Tee - NEXT D Beam unit satisfactorily furnished and placed in accordance with the plans and specifications.

**BASIS OF PAYMENT**

The unit price bid shall include the cost of furnishing all labor, materials, shims, and equipment necessary to satisfactorily complete the work, except that bearings shall be paid for under their respective item. This work does not include field placement of reinforcement or casting of longitudinal closure pours.

Damaged units which cannot be satisfactorily repaired or which do not meet dimensional and camber tolerances shall be replaced by the Contractor at no additional cost to the State. Any operations on the beams by the Contractor to meet surface tolerance requirements (such as diamond grinding) shall require approval from the Engineer and shall be at no additional cost to the State.

*Payment will be made under:*

<b>Item No.</b>	<b>Item</b>	<b>Pay Unit</b>
563.0001NN08	Prestressed NEXT D Beam, Type 1	Foot
563.0001NN08	Prestressed NEXT D Beam, Type 2	Foot

*NN = Type Designation (1 or 2, as shown on the plans)*

**DESCRIPTION**

This work shall consist of furnishing and installing a precast end diaphragm in accordance with the contract documents and as directed by the Engineer.

**MATERIALS**

All materials shall conform to the NYSDOT Prestressed Concrete Construction Manual (PCCM) and the Standard Specifications.

## A. Concrete

28 Day Compressive Strength	5,000 psi	(Minimum)
Lifting Strength	3,000 psi	(Minimum)
Water	§ 712-01	
Aggregates	§ 501-2.02.B.1	

## B. Bar Reinforcement

Epoxy Coated Bar Reinforcement	§ 709-04
Stainless Steel Bar Reinforcement	§ 709-13

## C. Stainless Steel

Stainless steel shall conform to the requirements of ASTM A167, or ASTM A240, Type 304. Stainless steel in contact with PTFE shall be polished to a No. 8, bright mirror finish. The minimum thickness of the stainless steel shall be as detailed on the plans.

Shear studs shall conform to the requirements of ASTM A276, Type 304 or 316.

**CONSTRUCTION DETAILS**

## A. Drawings

Shop drawings, installation drawings and erection drawings shall be prepared and submitted as per the requirements of the PCCM.



**ITEM 563.11000008 - PRECAST END DIAPHRAGM**

The submitted drawings shall include details of lifting, handling and storage of end diaphragm in the production facility and their transportation, handling, and storage at the construction site. The proposed handling and lifting shall be such that the maximum tensile stress in concrete due to handling and erection loads shall not exceed  $0.24(f'_{ci})^{1/2}$ , where  $f'_{ci}$  is the concrete compressive strength at the time being considered. Calculations showing actual concrete stresses based upon the proposed support locations and expected dynamic loading of the diaphragm during handling, storage and transportation shall be submitted along with the drawings. Dynamic load shall take into account inertial effects anticipated during handling and transport. These drawings and calculations shall be stamped and signed by a Professional Engineer.

**B. Fabrication of Precast End Diaphragm**

Fabrication shall meet the requirements of the PCCM and the following:

**1. Fabrication Tolerances:**

- a. Width (longitudinal direction of the bridge): +3/4, -3/16 in.
- b. Length (transverse direction of the bridge): +1, -1 in.
- c. Depth (overall): +9/16, -3/16 in.
- d. Reinforcement cover: +3/16, -0 in.

**2. Placing Concrete, Curing, and Finishing**

All requirements stipulated in the PCCM shall apply.

**3. Stainless Steel Sliding Surfaces**

Sliding surfaces shall be stainless steel plate with stainless steel studs, welded in accordance with AWS D1.6, current edition, and cast into the end diaphragm slide shoes.

**4. Shipping and Handling of Precast Diaphragms**

Shipping and handling shall meet the requirements in the PCCM and as stated on the approved drawings. The finished surface of the slide shoes shall be protected from damage during all phases of handling, such that no visible damage is present on the mating surface at the time of installation.

**C. Installation Requirements**

**ITEM 563.11000008 - PRECAST END DIAPHRAGM**

1. Installation shall be according to the installation drawings approved by the DCES and meeting the requirements of this specification and erection drawing approved by the Engineer.
2. At the time of installation, the finished sliding surface of the slide shoes shall be free of scratches, tears, burrs, indentions, or other defects that, in the judgment of the Engineer, have potential to damage the lower sliding surface and bearings during the lateral slide. Such defects shall be repaired to the satisfaction of Engineer prior to placing the end diaphragm on the temporary support.

**METHOD OF MEASUREMENT**

This work will be measured as the number of feet (horizontal length end to end, as shown on the plans) of end diaphragm satisfactorily furnished and installed per the Contract Documents.

**BASIS OF PAYMENT**

The unit price bid shall include the cost of furnishing all labor, materials, and equipment necessary to satisfactorily complete the work, including fabrication, storage, protection, transporting, unloading and installation of all precast end diaphragms. The cost shall include the stainless steel sliding surface, but the cost of bearings shall be paid for under their appropriate item.

**ITEM 565.14210008 - NON-GUIDED POLYTETRAFLUOROETHYLENE (PTFE)**  
**SLIDING BEARING**

**DESCRIPTION**

The work shall consist of furnishing, placing, and setting Non-guided PTFE Sliding Bearings at the locations shown on the Plans.

The Contractor shall notify the Deputy Chief Engineer, Structures (DCES) of the name and address of the fabricator of all bridge bearings in accordance with §106-01 Sources of Supply.

PTFE sliding bearings shall consist of a lower PTFE surface bonded to a steel-laminated elastomeric bearing. The upper component of this bearing system is a stainless surface on the bottom of slide shoes, which are included with, and paid for as part of, the precast end diaphragms.

PTFE sliding bearings shall be supplied as non-guided expansion bearings, as designated by the Contract Documents.

The non-guided expansion bearings shall allow longitudinal and transverse movement in the bearing plane.

**MATERIALS**

All material shall be new and unused, with no reclaimed material incorporated in the finished bearing.

1. Steel-Laminated Elastomeric Bearing Pads:

Material requirements of §565-2 apply for the steel-laminated elastomeric bearing components.

2. Polytetrafluoroethylene (PTFE) Sheet:

Polytetrafluoroethylene (PTFE) sheet shall be manufactured from pure virgin (not reprocessed) unfilled TFE resin or from TFE resin uniformly blended with either 15% glass fiber or 25% carbon (maximum filler, by percent weight). The resin shall satisfy the requirements of ASTM D4894.

Bonded PTFE sheet shall be etched on its bonding side. Unless otherwise noted on the Plans, PTFE sheet shall have a minimum thickness of 1/16" after compression. The mating sliding surface of filled PTFE sheet in contact with the stainless steel slide shoe shall be polished or burnished to insure smooth and low-friction movement of the bearing.

**ITEM 565.14210008 - NON-GUIDED POLYTETRAFLUOROETHYLENE (PTFE)**  
**SLIDING BEARING**

Finished PTFE sheet and strip shall be resistant to all acids, alkalis and petroleum products, stable at temperatures from -360° to 500°F, non-flammable, non-absorbing of water and shall conform to the following minimum physical requirements:

Physical Property	ASTM Test	Unfilled	Filled	
	Method		15% Glass	25% Carbon
Ultimate Tensile Strength, psi	D638	2800	2000	1300
Ultimate Elongation, %	D638	200	150	75
Specific Gravity	D792	2.13	2.18	2.05

**CONSTRUCTION DETAILS**

**A. Fabrication Details**

Every bearing shall have the Project Identification Number, NYSDOT Lot Number and individual bearing number indelibly marked with ink on a side that will be visible after erection.

The PTFE sheet shall be bonded to the top surface of the steel-laminated elastomeric bearing pad using an epoxy resin adhesive under controlled factory conditions in accordance with the instructions of the adhesive manufacturer.

Gross bearing dimensions shall have a tolerance of -0 to +1/8”.

**B. Performance Characteristics**

Sliding Coefficient of Friction:

The sliding coefficient of friction shall be calculated as the horizontal load required to maintain continuous sliding of one bearing, divided by the vertical load design capacity of the bearing. The vertical load shall have been applied continuously for a minimum of 12 hours prior to testing. The test results will be evaluated as follows:

- a. The measured sliding coefficients of friction shall not exceed 75% of the maximum design coefficient of friction.
- b. The bearing will be visually examined both during and after the test. Any resultant visual defects (such as bond failure, cold flow of PTFE, or damaged components) shall be cause for rejection.

ITEM 565.14210008 - NON-GUIDED POLYTETRAFLUOROETHYLENE (PTFE)  
SLIDING BEARING

**C. Sampling and Testing**

The manufacturer shall furnish the required number of samples to perform the tests as required. A minimum of thirty (30) days shall be allowed for the Department's inspection, sampling and testing procedures.

All exterior surfaces of sampled production bearings shall be smooth and free from irregularities or protrusions that might interfere with testing procedures.

The Department's representative shall select, at random, the required sample bearing(s) from completed lots of bearings, and samples of the PTFE materials for testing by the Materials Bureau. All samples shall be taken in accordance with the Department's written instructions.

Performance Characteristics:

Bearings shall be tested for performance characteristics by the Materials Bureau, Albany, New York. The contractor shall assume the responsibility and cost of transporting the required bearings from the place of manufacture to Albany and return.

The sampling rate shall be one in every ten in each size category, per project per production run, a minimum of two bearings. All bearings shall be returned to the Contractor.

The testing of the samples shall be as follows:

TEST	SAMPLES TESTED
Sliding Coefficient of Friction	One set of samples per project per size, per production run (1 set equals 2 bearings.)
Physical Properties of PTFE Sheet	One 10 x 15 inch sheet of PTFE per lot (Note 1.)

Note 1: The Materials Bureau will perform this testing. At the time of inspection, single sheets of PTFE sheets from which the bearing has been fabricated shall be submitted by the Department's representative. All submitted sample sheets shall be certified by the Manufacturer as having been taken from the same batch of material as was used in the actual production bearings.

**D. Drawings**

The contractor shall submit detailed shop drawings, drawn by the Manufacturer only, in conformance with the applicable requirements of the NYS SCM, for approval by the Regional Director prior to the start of fabrication. In addition, the manufacturer shall note the following on the shop drawings.

**ITEM 565.14210008 - NON-GUIDED POLYTETRAFLUOROETHYLENE (PTFE)**  
**SLIDING BEARING**

1. The total quantity of non-guided PTFE sliding bearings required.
2. The maximum design coefficient of friction.
3. The type of PTFE sheet (filled or unfilled) and, if applicable, the type and amount (by weight) of filler.
4. The type of epoxy resin to be used for bonding the PTFE to the elastomer, along with surface preparation requirements, as recommended by the adhesive manufacturer.
5. If applicable, any welding process used in the bearing manufacture or installation that does not conform to or is not addressed in the approved processes of the NYS SCM shall be clearly described and detailed. This shall include any welding of stainless steel.
6. The location of the fabrication plant.
7. The Manufacturer's name and the name of its representative who will be responsible for coordinating production, inspection, sampling and testing with the Materials Bureau.

The contractor shall also provide the Materials Bureau with written notification within thirty (30) days prior to the start of bearing fabrication. This notification shall include all of the information required by number 1 through 7 above. A copy of this notification shall be sent to the Regional Director.

**E. Basis of Acceptance**

Bearings shall be considered for acceptance in project lot quantities, or portions thereof, at the manufacturing site in accordance with the procedural directives of the Materials Bureau.

**F. Construction Details**

Bearings shall be installed at locations and in the manner shown in the plans, supplemented by the requirements for Type E.L. bearings in §565-3.

**METHOD OF MEASUREMENT**

This work will be measured as the number of bearings installed in accordance with the Contract Documents.

**ITEM 565.14210008 - NON-GUIDED POLYTETRAFLUOROETHYLENE (PTFE)**  
**SLIDING BEARING**

**BASIS OF PAYMENT**

The unit price bid for each bearing shall include the cost of all labor, materials, equipment and adjustment necessary to complete the work. All material between the support structure and the supported structure shall be included in the price bid for this item.

**DESCRIPTION****A. General**

The work shall consist of furnishing all horizontal slide equipment (mechanical devices, jacks, tracks and other components), performing lateral slide, monitoring of bridge movement, removal of lateral slide equipment, and performing of post-slide inspections and any necessary remedial actions. The work shall include furnishing, installing, and demolishing all temporary shoring structures.

Work shall include preparation and submittal of calculations and working drawings (with working load capacities) for horizontal slide equipment and temporary shoring.

**B. Prequalification of Bidders**

The Contractor executing the horizontal slide shall have documented previous experience in performing horizontal slides of three (3) successfully completed similar projects. Contractor shall also submit qualifications and prior experience in the use of the horizontal slide system and controls proposed for this project to the DCES for review.

**C. Related Sections**

§202: Removal of Structures and Obstructions

**D. References**

1. NYSDOT LRFD Bridge Design Specifications, current edition
2. AASHTO Standard Specifications for Highway Bridges, Division II, current edition

**E. Definitions**

Horizontal Slide shall refer to all components (including but not exclusive of the jacks, tracks, pumps, PLC equipment) and processes (including but not exclusive of submittal preparation, execution of the bridge movement, monitoring of bridge movement, post-event inspections and remedial action) related to moving the newly erected superstructure from the temporary falsework onto the permanent substructure units.

Temporary Shoring shall refer to all components of the structure erected adjacent to the current bridge locations supporting all the construction activities to erect the complete superstructure including but not exclusive of the bents, lateral bracing, foundations, work platforms and all personnel safety systems.



**F. Submittals**

## 1. Working Drawings, Calculations and Procedures

- i. The Contractor shall design all elements of the temporary falsework and horizontal slide system. Design shall be done in conformance with the current edition of the AASHTO LRFD Bridge Construction Specifications. Alternatively, the design shall be in conformance with the current edition of the AASHTO Standard Specifications for Highway Bridges, Division II.
- ii. Submit detailed Working Drawings, Calculations and Procedures of all equipment, materials and processes required for the horizontal slide and temporary shoring in accordance with the Steel Construction Manual.
- iii. Working drawings for the horizontal slide shall be submitted to the DCES for review at least 60 days prior to performing the horizontal slide.
- iv. Working drawings for the temporary falsework shall be submitted to the DCES for review at least 30 days prior to the beginning of falsework erection.
- v. The Deputy Chief Engineer (Structures) shall be allowed the longest of the following time durations to examine design computations and working drawings:
  - Fifteen working days.
  - Two working days for each drawing of a set of working drawings.
  - One working day for every four (4) design computation sheets. Any design computation sheet written on both sides will be considered as two design computation sheets.

All time for examination shall begin upon receipt of all pertinent information by the Deputy Chief Engineer (Structures).

- vi. The Deputy Chief Engineer (Structures) comments shall be indicated on the returned copies. Should the proposed system not be approved, the reasons shall be indicated with the return of the material. The Contractor shall then submit revised drawings for approval, subject to the same terms as the first submission. Resubmission shall not be considered a legitimate reason to request an extension of time.

ITEM 585.35010008 – HORIZONTAL SLIDE AND TEMPORARY SHORING

- vii. Do not order materials or begin work until written approval or authorization is granted by the DCES. The Contractor shall bear all costs and/or damages which may result from the ordering of any materials, or equipment; or the use of any preparatory labor prior to the approval of the working drawings.
- viii. Do not deviate from the approved Working Drawings and Procedures unless authorized in writing. All work shall be done in accordance with the approved working drawings. The Contractor must have approved working drawings prior to the erection of the temporary falsework.
- ix. Review and approval of the Working Drawing by the DCES shall not relieve the Contractor of the responsibility for the adequacy and design of temporary falsework and horizontal slide systems.
- x. Costs incurred due to faulty design or detailing are the Contractor's responsibility.

MATERIALS

- A. Use qualified suppliers for all jacking products. Qualified suppliers shall have a minimum of 10 years' experience in manufacturing and/or programming equipment used in the proposed horizontal slide. Contractor shall submit experience and qualifications for review. Proprietary systems may be used in lieu of constructing a new system specific to this project provided all components of the proprietary system have certifications and current calibrations indicating the equipment is sufficient for the needs of this project.
- B. Steel and hardware for temporary shoring shall be in accordance with §564. Used materials will be allowed, as approved by the DCES, except that materials that are permanently attached to the structure shall be in conformance with the current New York State Department of Transportation Standard Specifications.

If the Contractor proposes to construct with used materials, the Contractor's Professional Engineer shall submit with the plans the method for documenting that all primary member material meets the physical properties required by the design. In the absence of record plans or other valid documentation for the used materials, physical testing shall be performed. Excluded from this provision are proprietary structures.

**ITEM 585.35010008 – HORIZONTAL SLIDE AND TEMPORARY SHORING**

All welding required for the fabrication of temporary steel structures shall be performed in accordance with the provisions of the NYS Steel Construction Manual. Complete penetration groove welds in primary members shall be radiographed as described therein.

The DCES reserves the right to perform in-process fabrication inspection. The Contractor shall notify the DCES of the fabrication schedule 7 calendar days prior to commencement of fabrication.

- C. Concrete for temporary shoring shall meet the requirements of §555.

**CONSTRUCTION DETAILS****A. General Requirements**

1. Use methods and procedures to provide adequate safety to the general public from all construction activities and superstructure delivery and erection.
2. If the Contractor chooses to deviate from use of previously approved materials, components, Working Drawings or Procedures, the Contractor shall resubmit revised Working Drawings and Procedures to the DCES for approval.
3. All fabrication shall conform to the AASHTO Standard Specifications for Highway Bridges, Division II or AASHTO LRFD Bridge Construction Specifications, except as modified herein. Fabrication shall be performed by an AISC Category III-Certified Fabricator.
4. Construction requirements for the Temporary Shoring shall meet the requirements of §555-3, §564-3, and the Steel Construction Manual.
5. Construction requirements for the Horizontal Slide System shall meet the requirements of §564-3, and the Steel Construction Manual.

**B. Horizontal Slide and Temporary Shoring – Submittal Process**

1. Submittal Requirements and Process
  - i. Provide details necessary to move the new bridge into its final position using horizontal slide methods. Key information required is summarized below.
    1. The Contractor shall design any modifications to the permanent bridge details and/or bridge materials indicated on the Contract Plans as may be needed. Include calculations prepared by the

Bridge Contractors' Specialty Engineer, the Heavy Lift Engineer or the Contractor's Geotechnical Engineer.

2. Provide details of the horizontal slide components (including but not exclusive of the jacks, tracks, pumps, PLC equipment) and processes (including but not exclusive of submittal preparation, execution of the bridge movement, monitoring of bridge movement, post-event inspections and remedial action).
3. Provide details of the temporary falsework components (including but not exclusive of the bents, lateral bracing, foundations, work platforms and all personnel safety systems).

## 2. Professional Requirements

- i. Provide Working Drawings for the horizontal slide system, the temporary shoring structure, and all modifications to the permanent bridge superstructure. Working Drawing shall be sealed by a Professional Engineer, with appropriate, demonstrated knowledge and experience in the design, use, and operation of these types of systems and structures,
- ii. Working Drawings, Calculations and procedures for the horizontal slide system and the temporary falsework structure shall be prepared and sealed by a Professional Engineer with appropriate, demonstrated knowledge and experience in the design, use and operation of these types of systems and structures.
- iii. Working Drawings and Calculations for all Geotechnical Engineering work necessary for the temporary falsework shall be prepared and sealed by a Professional Engineer, with appropriate, demonstrated knowledge and experience in the design, use and operation of these types of systems and structures.

## C. Design Criteria and Standards

### 1. General

It is the intention that all design necessary for the horizontal slide and temporary falsework shall be carried out to the latest industry criteria and standards applicable to the particular item and work involved.

### 2. Design Criteria and Standards

**ITEM 585.35010008 – HORIZONTAL SLIDE AND TEMPORARY SHORING**

- i. Meet the requirements of AASHTO LRFD Bridge Design Specifications (current edition) for modifications to the permanent bridge superstructure necessitated by the Contractor's elected horizontal slide system.
- ii. Meet the requirements of AASHTO LRFD Bridge Construction Specifications (current edition).
- iii. In the absence of any other stated referenced national code based criteria, for the design and use of the horizontal slide system and temporary shoring structure, use as a minimum the requirements of AASHTO Guide Design Specifications for Bridge Temporary Works (2008 Interim).
- iv. For items not addressed by the above documents or for any other circumstances, submit a proposal and seek the guidance and approval of the DCES prior to proceeding.

**D. Horizontal Slide and Temporary Works (Working Drawings)**

## 1. General

- i. It is the overall responsibility of the Prime Contractor to coordinate all planned activities and submittals.
- ii. In general, specify all materials, details and procedures related to the construction and implementation of the proposed horizontal slide system and temporary falsework structure.
- iii. Use materials for the project that are of satisfactory quality, from sources approved by the DCES and that must be capable of sustaining the loads and stresses required. The Owner reserves the right to reject any material considered unsuitable or unsatisfactory. The Contractor is required to provide satisfactory material at no additional expense to the State.

## 2. Bridge Staging Area (BSA) Layout:

Show site plans and details of the Bridge Staging Area including but exclusive of the location and general layout of the site with existing, temporary and permanent structures indicated. Provide proposed locations of benchmarks or other reference locations for geometry control and survey purposes.

## 3. Bridge Staging Area (BSA) Geotechnical Requirements:

- i. The Contractor's Geotechnical Engineer shall verify that the Bridge Staging Area is suitable for all proposed construction operations and shall

develop/design methods to stabilize all excavations and to support the temporary falsework.

1. Provide design and details for all temporary foundation systems.
2. Provide Calculations demonstrating the temporary foundations' anticipated settlements and details for adjusting for differential settlements between the temporary and permanent foundations.

#### 4. Temporary Shoring

Provide calculations for all falsework elements and working drawings showing the location and details of temporary bents used to support the construction activities for permanent superstructure. Include bents, bracing, foundations, work platforms, personnel safety details and support of sliding track. Indicate the type and grade for all materials.

Provide calculations and details for methods used to stabilize excavations.

Take responsibility for the overall design, engineering and construction of temporary support structures. The Contractor's Specialty Engineer shall sign, seal and take responsibility of all Working Drawings and Calculations for the design of the temporary falsework.

If attachment of the temporary falsework to the permanent bridge substructure is required for any reason (i.e. strength or stability of frames or moving systems), the Contractor shall submit calculations and details for any proposed attachments/modifications to the DCES for approval.

#### 5. Horizontal Slide

Show details of proposed jacking system including but not exclusive of the jacks, tracks, pumps, PLC equipment, and schematic hydraulic layout, used to move the bridge superstructure from the temporary structure onto the permanent bridge substructure. Indicate the distance that the superstructure is to be moved.

Provide type and grade for all materials.

Clearly show on the Working Drawings and in the Calculations the push/pull capacity of the horizontal slide system and limitations during all jacking operations. Provide jacking/pulling locations.

Provide a detailed slide procedure, including but not limited to execution of the bridge movement, monitoring of the bridge movement, post-event inspections and

**ITEM 585.35010008 – HORIZONTAL SLIDE AND TEMPORARY SHORING**

remedial action. Procedures shall include checklists to support the activities prior to, during and after the bridge superstructure has been moved to its final location.

Provide checking (QC/QA) procedures prior to the horizontal movement of the superstructure in order to ensure its completion.

Provide contingency plans in the event of a major breakdown or equipment malfunction.

Provide operational details for the control of the movement, including any system of check-off items for the operators and for safety purposes.

The Contractor's Specialty Engineer shall sign, seal and take responsibility of all Working Drawings, Calculations and Procedures for the design and execution of the horizontal slide.

If attachment of the horizontal slide system to the permanent bridge substructure is required for any reason, the Contractor shall submit detailed calculations and drawings for any proposed attachments/modifications to the permanent bridge details and/or materials to the DCES for approval.

#### 6. Permanent Superstructure

- i. The Contractor's Specialty Engineer is responsible for all modifications made to the details for the construction of the permanent bridge superstructure. The Contractor's Specialty Engineer shall sign, seal, and take responsibility of all Working Drawings and Calculations for modifications to the permanent superstructure. All Working Drawings and calculations shall be submitted to the DCES for approval.
- ii. Details for modifications of details related to the permanent superstructure include, but not necessarily limited to the following:
  1. Details of and supporting calculations for any modifications to reinforcement at anchorages, diaphragms, deck-slabs, block-outs and the like made that may be necessary for accommodating the proposed horizontal slide system.
  2. The Contractors' Specialty Engineer will provide repair procedures for any damage or cracking to the permanent bridge components (substructure and/or superstructure) resulting from the movement of the bridge superstructure.

#### 7. Geometry Control:

Prior to commencing construction of the superstructure in the Bridge Staging Area, submit proposed method of geometry control to the DCES for approval. The submittal is to contain actual details of the proposed temporary falsework structure and horizontal slide system, and shall be in the form of Working Drawings and should include but is not necessarily limited to items such as:

- i. Measuring equipment, procedures and locations of geometry control reference points on the superstructure, in the Bridge Staging Area and at the Bridge site.
- ii. The location and values of permanent benchmarks and reference points in the staging area and at the bridge site.
- iii. During erection and casting of wearing surface, as a minimum, establish and maintain a record of key vertical elevations along the main longitudinal elements (i.e. centerline of beams or precast approach panels) and along the proposed horizontal slide track supports. Submit all records to the Engineer.
- iv. Establish lateral and longitudinal location reference points on the erected superstructure that correspond to, or can be referenced to appropriate lateral and longitudinal reference points at the erection site.

#### **E. Preparation for Movement of Superstructure**

##### 1. General

- i. The Bridge Contractor has overall responsibility for the construction of temporary falsework structure and horizontal slide system in accordance with the approved Working Drawings and procedures.
- ii. Accurately calculate slide forces, including an accurate weight take off of the total weight of superstructure to be moved and the anticipated maximum coefficient of friction between sliding points.
- iii. Follow established QA/QC procedures and prepare a Pre-Operations Check-List as appropriate and necessary for information and coordination purposes.

##### 2. Horizontal Slide System

- i. Follow approved Working Drawings for details, sequences of procedures for positioning the jacks and track.



**ITEM 585.35010008 – HORIZONTAL SLIDE AND TEMPORARY SHORING**

- ii. Carefully jack superstructure horizontally in an incremental fashion. Maintain even push strokes between all jacking points. Jacks shall be able to be controlled as a group and/or as individual units. Provide controls to reset jacks as a group and/or as individual units.
- iii. Operate horizontal slide system with care and within anticipated limitations (stroke limits) of the jacking systems. Follow limitations on Working Drawings for all incremental and differential jacking with due regard to assuring minimal differential movement between all slide locations.
- iv. Implement checking (QC/QA) procedures prior to a transportation operation in order to ensure satisfactory completion.
- v. Implement contingency plans in the event of a major breakdown or Equipment malfunction.
- vi. Operational details for the control of the movement shall be provided in an “Operations Manual” which shall also include a system of check-off items for the Operators and for safety purposes. Treat such an “Operations Manual” as a Working Drawing for submittal and approval.

**F. Trial Horizontal Slide**

The Contractor is required to perform a trial horizontal slide for each structure, following approved horizontal slide procedures in the Working Drawings. This trial slide shall occur a minimum of 5 days prior to the slide of the bridge into its final position. The Contractor shall notify the Engineer of the date and time at which the trial slide is to occur in writing a minimum of 3 days prior to the trial slide. The Contractor shall be required to move the structure a minimum of 15'-0" and return it to its temporary position. The trial slide should include moving the new superstructure a minimum distance of 5'-0" onto the new abutments to test the slide performance on the new structures. As the sleeper slabs may not yet be in place at the time of the trial slide, the Contractor is required to supply temporary sliding surfaces at the ends of the approach slab. The contractor shall monitor any additional settlements at the temporary falsework during the trial slide.

**G. Movement of Superstructure**

## 1. General

- i. The intent during movement is to ensure that the structure is delivered to the Owner, in its final location, with no damage or adverse loss of

strength, loss of performance or loss of long term durability. To this end, it is necessary to place certain limitations upon characteristics that can be quantified and observed or checked by careful observations or by using suitable detection methods during these operations. Any damages to the permanent structure caused by the move after the bridge is in its final position shall be repaired at no cost to the State.

- ii. The Bridge Contractor takes responsibility for establishing geometric alignment and elevation reference controls at the Bridge Staging Area and Bridge Site. Establish survey control points and benchmarks as necessary. Establish transverse and longitudinal reference lines - e.g. centerlines of bearings, offsets from fixed surfaces - for setting superstructure span or spans on bearings, as necessary.
- iii. Keep records of observations and operations. Submit all records to the Engineer. Notify Engineer in event of errors and submit proposals for corrective adjustments or modifications to any of the permanent structure or components to the Engineer for approval prior to their implementation.

## 2. Tolerances

- i. Plan Alignment, Location, Clearances
- ii. For the final condition of the span after placement in the bridge:
  1. Do not exceed  $\frac{1}{4}$  inch maximum deviation at each end of span from overall longitudinal alignment of an individual span after setting.
  2. Do not exceed  $\frac{1}{4}$  inch maximum deviation from overall transverse location (i.e. longitudinal position) at each line of bearings.
  3. Maximum deviation from alignment in both primary plan directions (yaw) at each end of the span or spans being set shall not exceed  $\frac{1}{4}$  inch or that required for the accommodation of manufactured expansion joint components or bearings, whichever is the less.
  4. In the absence of other constraints, keep individual elements or surfaces within  $\frac{1}{4}$  inch of location with respect to similar matching surfaces at expansion joints (i.e. plane of web or parapet) of adjacent spans, pier or abutment features.
- iii. During Movement

**ITEM 585.35010008 - HORIZONTAL SLIDE AND TEMPORARY SHORING**

The contractor shall ensure that the superstructure itself remains as free as possible from harmful effects of differential movements at all sliding surfaces.

**3. Movement of Superstructure - Step-by-Step Procedures**

Follow procedures approved by the DCES in the sliding procedures on the Working Drawings for the step-by-step sequence of operations for movement of the superstructure span.

**METHOD OF MEASUREMENT**

This work will be measured for payment on a lump sum basis.

**BASIS OF PAYMENT**

The unit price bid for the horizontal slides shall include the cost of all labor, materials, equipment and adjustment necessary to complete the work. All labor, materials, and equipment required for the trial slide shall be included in the price bid for this item. All temporary falsework necessary to support the structure prior to and during the horizontal slide and their removal upon completion of the horizontal slide shall be included in the price bid for this item.

**ITEM 595.98200018 – SPRAY-APPLIED WATERPROOFING MEMBRANE****DESCRIPTION**

Furnish and install a spray-applied, waterproofing membrane system in accordance with the contract documents, approved Material Detail Sheets, and as directed by the Engineer. Include all surface preparation and quality-control testing of substrates and the applied membrane.

**MATERIALS**

Use a spray-applied, waterproofing membrane system appearing on the Department's Approved List; Materials and Equipment for Use on New York State Department of Transportation Projects.

The membrane system shall meet the requirements found under the **Membrane System Application and Quality-Control Testing** section of this specification.

**BASIS OF ACCEPTANCE.**

Spray-applied, waterproofing membranes will be accepted on the basis of the Manufacturer's name, the brand name of the system, and approved Material Detail Sheets appearing on the Department's Approved List of Materials and Equipment for use on NYSDOT Projects.

**CONSTRUCTION DETAILS**

**General.** Arrange for the membrane system manufacturer to have a competent technical representative with necessary equipment to perform the quality-control testing at the job site during all phases of preparation and installation. The technical representative is responsible to perform quality-control testing during membrane application. The technical representative will present all quality-control testing equipment to the Engineer to verify calibration dates and demonstrate their competency to perform quality-control testing.

Supply Material Safety Data Sheets (MSDS) and approved Material Detail Sheets prepared by the membrane manufacturer to the Engineer a minimum of two weeks prior to the scheduled commencement of work. Protect personnel exposed to primers and membranes in accordance with MSDS. Store all components of the membrane system, including broadcast aggregates, at the job site in accordance with approved Material Detail Sheets.

Use tarpaulin or other suitable masking to protect traffic, the surrounding environment, and adjacent features from over spraying.

**Membrane System Application and Quality-Control Testing.**

**Substrate Preparation.** Prepare all surfaces that are to receive the membrane system in accordance with the approved Material Detail Sheets. Blast clean all surfaces as a minimum. Remove residual matter using brooms and oil/moisture-free compressed air.

**Substrate Moisture Content and Temperature.** Measure the surface moisture content and temperature before applying the primer and membrane. The surface moisture content and temperature will be within allowable tolerances as stated in the approved Material Detail Sheets. Perform one test for every two thousand square feet of area as specified in the contract documents or a minimum of three tests.

**ITEM 595.98200018 – SPRAY-APPLIED WATERPROOFING MEMBRANE**

Substrate Cohesion/Primer Adhesion. After the substrate has been prepared to the satisfaction of the Engineer, test the cohesion of the substrate and the adhesion of the primer to the substrate in accordance with *ASTM D4541 – Pull-Off Strength of Coatings Using Portable Adhesion Testers*. Conduct tests after the primer has sufficiently cured as determined by the technical representative. Perform one test for every two thousand square feet of prepared substrate area, and at locations where deficient adhesion is suspected by the Engineer or a minimum of three tests. Minimum adhesion strengths of 300 psi for each test on steel or 150 psi on Portland Cement Concrete substrates are required before applying primer to the remaining surface area.

Primer Application. Apply primer to the remaining substrate surface area at a rate specified in the approved Material Detail Sheets.

Membrane Application. Apply each course of the membrane at a rate specified in the approved Material Detail Sheets.

Membrane Thickness. Measure the wet-film thickness of each course of membrane using a standard comb-type thickness gauge or measure the dry-film thickness of each course of membrane using a dry-film thickness gauge for nonferrous substrates. Submit alternative methods for measuring thickness to the Engineer for approval.

Take one measurement for every one hundred square feet of membrane applied. The measured thickness of each course of the membrane and the entire thickness of the finished membrane will be greater than or equal to the depth specified in approved Material Detail Sheets.

Membrane Pin Holes. Test for pin holes in the cured membrane system over the entire application area in accordance with *ASTM D4787 – Continuity Verification of Liquid or Sheet Linings Applied to Concrete Substrates*. Conduct the test at voltages recommended by the manufacturer to prevent damage to the membrane.

Membrane Adhesion. Test the adhesion of the membrane system to the substrate in accordance with *ASTM D4541 – Pull-Off Strength of Coatings Using Portable Adhesion Testers*. Conduct tests after the membrane system has sufficiently cured as determined by the technical representative. Perform one test for every two thousand square feet of membrane applied, and at locations where deficient adhesion is suspected by the Engineer or a minimum of three tests. Minimum adhesion strengths of 300 psi for each test on steel or 150 psi on Portland Cement Concrete substrates are required.

Repair and correct any deficiencies in the membrane system and substrate noted during quality-control testing as recommended by the manufacturer's representative to the satisfaction of Engineer at no additional cost to the State.

Binder Aggregate Application. When cold-applied, wearing-surface overlays are specified, or additional shear resistance between the membrane and the wearing surface is desirable, broadcast an aggregate binder onto the membrane in accordance with the approved Material Detail Sheets.

Apply the aggregate binder to the membrane before the membrane cures and as specified in the approved Material Detail Sheets. The aggregate and membrane will be fully integrated after the aggregate has been applied and the membrane has cured. Remove loose aggregate with brooms or oil/moisture-free compressed air before applying the tack coat.

**ITEM 595.98200018 – SPRAY-APPLIED WATERPROOFING MEMBRANE**

Tack Coat Application. Apply a tack coat to the finished membrane system if needed and as specified in the Material Detail Sheets prior to overlaying the membrane with a wearing surface.

**METHOD OF MEASUREMENT**

This work will be measured as the number of square feet of spray-applied, waterproofing membrane system satisfactorily furnished and installed as shown on the contract plans or ordered by the Engineer.

**BASIS OF PAYMENT**

The unit price bid shall include the cost of furnishing all labor, materials, and equipment necessary to satisfactorily complete the work.

**ITEM 607.9600008 - REMOVE AND DISPOSE OF EXISTING FENCE****DESCRIPTION:**

The contractor shall remove existing fence in accordance with the plans, specifications and directions of the Engineer. All references to "fencing" shall include existing gates, if any to be removed.

**MATERIALS:**

Materials needed for modifying end sections shall conform to the requirements of Section 710 of the Standard Specifications or shall conform to the material requirements of the existing fence, as directed by the Engineer.

Concrete for footings shall conform to Section 607-2.01 of the Standard Specifications.

**CONSTRUCTION DETAILS:**

The contractor shall remove and dispose of the existing fence to a point shown on the plans or where directed by the Engineer. If a portion of the existing fence is to remain, the remaining end section shall be modified to adequately secure the fencing. This modified section shall include all hardware necessary to secure the fencing in a manner similar to the existing end section or as directed by the Engineer. Parts salvaged from the removed portion, acceptable to the Engineer, may be reused in the end section.

All work shall be done in a workmanlike manner with care taken not to disturb the surrounding area or existing fence to remain. Any damage to the area or existing fence to remain caused by the contractor's operations shall be repaired to the original condition at no expense to the state. Any concrete post footings shall be either broken up and removed or removed in one piece as determined by the contractor and approved by the Engineer. All post holes shall be filled to meet existing grade. All excavation and backfill shall conform to Section 203 "Excavation and Embankment".

**METHOD OF MEASUREMENT:**

This work will be measured as the number of feet of fence removed in accordance with the plans or as directed by the Engineer. An additional 10 foot allowance will be paid for each end section modified to secure the remaining fence.

**BASIS OF PAYMENT:**

The unit price bid shall include the cost of all labor, equipment and materials necessary to complete the work, including the cost of any fill required to fill the post holes.

**ITEM 619.55010108 - DEDICATED POLICE SERVICES****DESCRIPTION:**

This work consists of reimbursing the municipality police for dedicated police services provided during construction for such periods and at such locations as directed by the Engineer for the control and direction of vehicular traffic.

**MATERIALS:**

Not Applicable.

**CONSTRUCTION DETAILS:**

Traffic officers shall be uniformed sworn Police Officers. Services will also include the usage of an official Police vehicle and associated equipment.

The contractor shall receive invoices from the Engineer summarizing the actual police services provided during construction. The contractor shall reimburse the municipality the stated invoice amount within 21 days of receipt. Once the municipality verifies receipt of the reimbursement, the Department will reimburse the contractor the invoice amount plus five percent for administrative costs.

**METHOD OF MEASUREMENT:**

The dollar-cents amount set forth in the proposal is a fixed price for all bidders and shall not be changed. If the amount is altered, the new figure will be disregarded and the original amount used to determine the total amount bid for the contract.

**BASIS OF PAYMENT:**

Payment for this item will be based on the actual billing submitted by the Contractor for the work performed. The dollar-cents amount reimbursed will be the documented amount paid to the provider of dedicated police services, and with an additional five percent being paid to the contractor for administrative costs.



**ITEM 621.51000015 - GRADING CLEANING AND RESHAPING EXISTING DITCHES**

**Description:** This work shall consist of grading, cleaning and reshaping existing ditches so that adequate, unobstructed free flowing drainage is restored.

The Contractor shall:

- A. Grade, clean and reshape the existing ditches including removal of excess material as ordered by the Engineer to restore drainage.
- B. Shape the backslope in cut sections up to the final elevation of the nearest edge of pavement.

**Materials:** (Not Specified)

**Construction Details:** The grading, cleaning and reshaping of existing ditches shall consist of rendering the ditches free of obstructions including the removal of earth, sod, brush and debris.

Material removed from existing ditches shall be disposed of in conformance with the provisions of subsection 203-3.02 B. *Disposal of Surplus Excavated Materials*.

The Contractor shall exercise due care to protect all trees, fences, markers, culverts, underground structures, utilities and installations within and adjacent to the work area. Facilities damaged by the Contractors operation shall be replaced in kind at no expense to the State.

**Method of Measurement:** This work shall be measured as the number of linear feet of ditch along which such above described work is performed.

**Basis of Payment:** The unit price bid per linear feet for this work shall include the cost of furnishing all labor, material and equipment necessary to satisfactorily complete the described work except that the following items of work will be paid for under their respective pay items:

- A. Seeding and mulching of disturbed areas within the ROW.
- B. Cleaning of culverts.
- C. Required shoulder excavation as ordered by the Engineer.
- D. Required shoulder trimming and reshaping as ordered by the Engineer.
- E. Slope excavation and shaping in cut sections required above the final elevation of the nearest edge of pavement.

**ITEM 623.12000008 - CRUSHED STONE (IN PLACE MEASURE) MODIFIED**

All specification requirements for Item 623.12 shall apply except for the following additions:

**MATERIALS:**

- 1) Material supplied shall meet the requirements of Concrete Aggregate Type CA 2 as shown on Table 501-2 of the Standard Specifications.
- 2) Material shall be stockpiled, sampled and tested in conformance with the procedures contained in the appropriate Departmental publications which are current on the date of advertisement for bids. On contracts containing less than 100 cubic yards in total quantity, the stockpiling requirement may be waived by the Regional Geotechnical Engineer.

**METHOD OF MEASUREMENT:**

A deduction shall be made for pipes (based on nominal diameters) and other payment items, when the combined cross-sectional area exceeds 1 square foot, unless otherwise shown on the plans. No deduction will be made for the cross sectional area of an existing facility.

## ITEM 639.10220001 – CPM (CRITICAL PATH METHOD) PROGRESS SCHEDULE - Type 2

**DESCRIPTION**

This work shall consist of preparing, maintaining and submitting a Progress Schedule using the Critical Path Method on Primavera P6 software, or newer release, which demonstrates complete fulfillment of all work shown in the contract documents. All work to prepare, and maintain the CPM Progress Schedule shall be performed using the scheduling software application provided by the Department on network servers and accessed through the Internet with Department provided user accounts. The Contractor shall regularly revise and update the Progress Schedule, and use it in planning, coordinating, and performing all work. Schedule activities shall accurately depict the entire scope of work to be performed to complete the project including, but not limited to, all work to be performed by the Contractor, subcontractors, fabricators, suppliers, consultants, the Department, and others, contributing to the project.

**DEFINITIONS**

**Activity** - A discrete, identifiable task or event that usually has an expected duration, has a definable Start Date and/or Finish Date, and can be used to plan, schedule, and monitor a project.

**Activity, Controlling** - The first incomplete activity on the critical path.

**Activity, Critical** - An activity on the critical path.

**Actual Start date**- At the activity level, the Actual Start date represents the point in time that meaningful work actually started on an activity.

**Actual Finish date** - At the activity level, the Actual Finish date represents the point in time that work actually ended on an activity (Note: in some applications areas, the activity is considered “finished” when work is “substantially complete.”); at the project level, the Actual Finish date represents the point in time that the Contractor completes all work on the project and it is accepted by the Engineer.

**Backward Pass** – Calculation of the late start and late finish dates for each activity, based on the start or finish dates of successor activities as well as the duration of the activity itself. Also known as the second pass.

**Baseline Progress Schedule @ Award**- The Progress Schedule submitted by the Contractor and accepted by the Department that shows the plan to complete the construction contract work. The Baseline Progress Schedule @ Award represents the Contractor’s plan at the time of contract Award for completing the Project.

**Bid Date** – The date the contract is let and there is an announcement by the Department of an apparent low bidder.

**Completion Date, Contract** - The date specified in the Contract for completion of the project or a revised date resulting from properly executed time extensions.

**Completion Date, Scheduled** - The date forecasted by the Progress Schedule for the completion of the Project.

**Constraint** - A schedule restriction imposed on the Start or Finish date(s) of an activity that modifies or overrides an activity’s relationships.

**Progress Schedule Delay** - An event, action, or other factor that delays the critical path of the Progress Schedule and extends the time needed for completion of the construction project.

## ITEM 639.10220001 – CPM (CRITICAL PATH METHOD) PROGRESS SCHEDULE - Type 2

**Contemporaneous Period Analysis Method** – A technique for evaluating schedule delays or time savings. The analysis period for the purpose of these provisions shall be the period covered in each regular progress update to the schedule, as they coincide with contract payments to the Contractor.

**Contractor Owned Float Activity** – The activity that documents time saved on the critical path by actions of the Contractor. It is the last activity prior to the contract Completion Date milestone activity.

**Contractor Start Work date** – The actual date the Contractor starts field work of a contract pay item, which is entered as a Start milestone activity in the schedule. Contractually no work may start until after the contract is awarded by the Office of State Comptroller, and the Contractor has received a Notice to Proceed from the Contract Management Bureau. Should the Contractor choose to show activities in the schedule that reflects their plan of work prior to the contract award, the Department does not incur any liability and such work being performed between the bid date and the contract award date shall be considered at risk work.

**Critical Path** – In the Progress Schedule the critical activities shall be those activities being on the longest path. In a project network diagram, the series of activities which determines the earliest completion of the project. The critical path will generally change from time to time as activities are completed ahead of or behind schedule.

**Critical Path Method (CPM)** – A network analysis technique used to predict project duration by analyzing which sequence of activities (which path) has the least amount of scheduling flexibility (the least amount of float). A scheduling technique utilizing activities, durations, and interrelationships/dependencies (logic), such that all activities are interrelated with logic ties from the beginning of the project to the completion of the project. Early dates are calculated by means of a forward pass using a specified start date. Late dates are calculated by means of a backward pass starting from a specified completion date (usually the forward pass's calculated project early finish date).

**Data Date** – The date entered in the Project Details, in the Dates tab, which is used as the starting point to calculate the schedule. For the Baseline Progress Schedule @ Award submission the Data Date shall be the contract Award Date; for Monthly Progress Schedule submissions, the Data Date shall be the date up to which the Contractor is reporting progress (generally the last working day for the corresponding contract payment period, and for Weekly Status Reports the Data Date shall be the Saturday of that week). If the Contractor submits a Baseline Progress Schedule @ Bid submission, the Data date shall be the date of the schedule submission to the Engineer and not prior to the bid date. Everything occurring earlier than the data date is "as-built" and everything on or after the data date is "planned."

**Deliverable** – Any measurable, tangible, verifiable outcome, result, or item that must be produced to complete a project or part of a project. Often used more narrowly in reference to an external deliverable, which is a deliverable that is subject to approval by the Department.

**Duration, Original** - The original estimated number of working days (not including holidays or other non-working periods) in which the work task associated with the activity is expected to be performed. (The number of calendar days may be different based on the calendar assigned to the activity.) For certain activities such as concrete curing, or others approved by the Engineer, the calendar shall reflect no non-working days.

**Duration, Remaining** - The estimated time, expressed in working days (not including holidays or other non-working periods), needed to complete an activity that has started but has not finished.

**Early Dates** – The earliest date an activity can start or finish based upon logic and durations. Calculated by the software application when scheduling the project.

## ITEM 639.10220001 – CPM (CRITICAL PATH METHOD) PROGRESS SCHEDULE - Type 2

**Early Completion Date(s)** - A progress schedule shall be considered to have an early completion date when the schedule submitted by the Contractor indicates an anticipated completion date(s) that is/are earlier than the specified contract milestone date(s), which includes:

- (i) the Scheduled Completion Date appearing as the “Finish” date in the Project Details, in the Dates tab, is earlier than the current contract Completion Date as of the Data Date of the progress Schedule.
- (ii) the Finish Date of any interim Milestone activity, that describes an item of work in the contract with a required completion date, is earlier than the date specified in the contract as of the Data Date of the progress Schedule. This includes, but is not limited to, B-Clock activities, activities subject to Incentive/Disincentive provisions, activities subject to specific Liquidated Damages provisions, and Lane Rental activities.

**Enterprise Project Management Database (EPMD)** – The Department’s database of construction project Progress Schedules.

**Final Baseline Progress Schedule @ Award** - The original plan against which the Contractor’s progress is measured. The Final Baseline Progress Schedule @ Award represents the original plan at the award of the contract, of what is expected to happen. Once the Final Baseline Progress Schedule @ Award is accepted by the Engineer it is saved and used as a basis to compare against Progress Schedules Updates.

**Float Suppression** - Utilization of zero free float constraints which allows an activity to start as late as possible by using all its' available free float. This technique allows activities to appear more critical than if the activity's total float was based on early dates. Assigning zero free float prevents true sharing of total float between Department and the Contractor. Examples of float suppression techniques include preferential sequencing (arranging the critical path through activities more susceptible to State caused delay), extending activities durations, incorporating several activities that actually require a half day or less of effort with Finish to Start relationships but showing each as full day durations where one activity would be appropriate, manipulating calendars, or any other such methodology.

**Float, Free** - The amount an activity can slip without delaying the immediate successor activities. Free Float is the property of an activity and not the network path.

**Float, Total** - The amount of time an activity (or chain of activities) can be delayed from its early start without delaying the contract completion date. Float is a mathematical calculation and can change as the project progresses and changes are made to the project plan. Total Float is calculated and reported for each activity in a network, however, Total Float is an attribute of a network path and not associated with any one specific activity along that path.

**Fragnet** – A subdivision of a project network diagram usually representing some portion of the project.

**Global data** – Data classified by Primavera software as Global, including Project Codes, Global Activity Codes, Global Calendars, Resource Calendars, Global Filters, Resources, Global Reports, User Defined Fields and Unit of Measure. Global Activity Codes are used to organize project activities across the enterprise project structure according to specific categories, such as the Code Value STG1 for Stage 1 under the Global Activity Code STAGE. Whereas Project Activity Codes are used to organize project activities for a specific project only.

**Initial Baseline Progress Schedule** – The Contractor’s schedule prior to submittal to the Engineer of the Baseline Progress Schedule @ Award, that reflects the Contractor’s plan to perform work during the time period while the full Baseline Progress Schedule is being developed, reviewed and accepted.

## ITEM 639.10220001 – CPM (CRITICAL PATH METHOD) PROGRESS SCHEDULE - Type 2

**Key Plans** - Key Plans are graphic representations made by the Contractor's project Scheduler on paper copies of the appropriate contract plan sheets that reflect the Contractor's planned breakdown of the project for scheduling purposes to efficiently communicate the Contractor's activity coding scheme to State scheduling staff. The key plans prepared by the Contractor shall clearly define the boundaries of the work for each designated Area, the operations contained in various Stages of work, and work in the Work Zone Traffic Control (WZTC) Phases. The alphanumeric codes on the key plans shall match the code values for the activity code "Area", "Stage", and "WZTC Phase" in the Progress Schedule.

**Late Dates** – "Drop dead dates". The latest an activity can start or finish without delaying the day of completion. Calculated by the computer during the backward pass.

**Longest Path** - The sequence of activities through the Progress Schedule network that establishes the Scheduled Completion Date

**Look-Ahead Schedule** – Commonly a one or two week time segment generated from the accepted Progress Schedule that forecasts the work planned for the one or two week period following the Data Date, and includes any major materials to be delivered and any lane closings or anticipated shifts in WZTC.

**Milestone** – An activity with zero duration that typically represents a significant event, usually the beginning and end of the project, milestones set forth in the contract proposal, construction stages, a major work package, or the contract interim time-related clauses.

**Narrative Report** - A descriptive report submitted with each Progress Schedule. The required contents of this report are set forth in this specification.

**Open End** - The condition that exists when an activity has either no predecessor or no successor, or when an activity's only predecessor relationship is a finish-to-finish relationship or only successor relationship is a start-to-start relationship.

**Predecessor** - An activity that is defined by Schedule logic to precede another activity. A predecessor may control the Start Date or Finish Date of its successor.

**Progress Schedule** – A general Primavera P6 Schedule as defined by this Specification.

**Progress Schedule Update** – Changes to the Progress Schedule that reflect the status of activities that have commenced or have been completed, including the following items: (a) Actual Start date and or Actual Finish date as appropriate; (b) Remaining Duration for activities commenced and not complete; and (c) Suspend or Resume dates for activities commenced and not complete.

**Progress Schedule Revision** – Revisions to the Progress Schedule ensure it accurately reflects the current means and methods of how the project is anticipated to progress, including modifications made to any of the following items: (a) changes in logic connections between activities; (b) changes in constraints; (c) changes to activity descriptions; (d) activity additions or deletions; (e) changes in activity code assignments; (f) changes in activity resource assignments; and (g) changes in calendar assignments.

**Project Scheduler** – The person that is responsible for developing and maintaining the Progress Schedule.

**Projects Planned Start Date** – The date entered in the Project Details, in the Dates tab, that reflects the Contractor's planned start of work (based on contract requirements, and reasonable expectation for a Notice to Proceed) at the time the bid was submitted to the Department.

## ITEM 639.10220001 – CPM (CRITICAL PATH METHOD) PROGRESS SCHEDULE - Type 2

**Projects Must Finish By Date** – A date constraint entered in the Project Details, in the Dates tab, that reflects the Contract Completion Date set in the Contract Documents or through a formal contract extension of time.

**Recovery Schedule** – A schedule depicting the plan for recovery of significant time lost on the project. This separate CPM schedule submission shall provide the resolution and include appropriate changes in network logic, calendar adjustments, or resource assignments.

**Relationships** - The interdependence among activities. Relationships link an activity to its predecessors and successors. Relationships are defined as:

**Finish to Start** - The successor activity can start only when the current activity finishes.

**Finish to Finish** – The finish of the successor activity depends on the finish of the current activity.

**Start to Start** – The start of the successor activity depends on the start of the current activity.

**Start to Finish** – The successor activity cannot finish until the current activity starts.

**Resources, Contract Pay Item** – Contract Pay Item resources shall be identified as a Material resource type. When required, Contract Pay Item resources are developed for each Pay Item in the contract, with the Resource ID matching the contract Pay Item and the Resource Name matching the description of the contract Pay Item.

**Resources, Equipment** – Equipment resources shall be identified as a Nonlabor resource type. A unique identifier shall be used in the Resource Name or Resource Notes to distinguish this piece of equipment from a similar make and model of equipment used on the project.

**Resources, Labor** – Labor resources shall be identified as a Labor resource type. Labor Resources shall identify resources that encompass direct labor at the Crew level.

**Scheduling/Leveling Report** – The report generated by the software application when a user “Schedules” the project. It documents the settings used when scheduling the project, along with project statistics, errors/warnings, scheduling/leveling results, exceptions, etc.

**State Business Days** – Monday through Friday, with the exception of State Holidays.

**State Owned Float Activity** – The activity that documents time saved on the critical path by actions of the State. It is the last activity prior to the Completion Date activity and any Contractor Owned Float activity.

**Substantial Completion** - the day, determined by the Engineer, when all of the following have occurred:

1. The public (including vehicles and pedestrians) has full and unrestricted use and benefit of the facilities both from the operational and safety standpoint, and
2. All safety features are installed and fully functional, including, but not limited to, illumination, signing, striping, barrier, guard rail, impact attenuators, delineators, and all other safety appurtenances, and
3. Only minor incidental work, replacement of temporary substitute facilities or correction or repair remains for the Physical Completion of the Contract, and
4. The Contractor and Engineer mutually agree that all work remaining will be performed without lane closures, trail/sidewalk closures, or further delays, disruption, or impediment to the public.

**Successor** - An activity that is defined by Schedule logic to succeed another activity. The Start Date or Finish Date of a successor may be controlled by its predecessor.

## ITEM 639.10220001 – CPM (CRITICAL PATH METHOD) PROGRESS SCHEDULE - Type 2

**Time Impact Analysis** - A technique to demonstrate the comparison of a time impact of a Progress Schedule revision prior to a change in the Contract work, against the current accepted Progress Schedule. Also known as a “What-If” analysis.

**Weekly Status Report** – The report generated weekly from the updated Progress Schedule in an electronic Adobe Acrobat PDF format that reflects a Data Date for that Progress Schedule Update period. The report shall be formatted to fit ANSI Size D paper (610 mm x 914 mm) (24 inch x 36 inch), listing all work activities from the data date to contract completion, using the NYSDOT Status Report Layout, sorted by Early Start Date, Total Float in increasing order, showing the Activity ID, Activity Description, Original Duration, Remaining Duration, Total Float, Early Start date, Early Finish date, Start date, Finish date and Calendar ID.

**Work Breakdown Structure (WBS)** - A deliverable-oriented grouping of project elements, which organizes and defines the total scope of the project. Each descending level represents an increasingly detailed definition of project components or work packages.

**Work Package** - A deliverable at the lowest level of the work breakdown structure. A work package contains activities.

**Working Day** - A Working Day is a calendar day scheduled for active prosecution of the work.

## **CONSTRUCTION DETAILS**

### **A. Project Scheduler:**

The Contractor shall designate an individual, entitled the Project Scheduler, who will develop and maintain the construction progress schedule. The Project Scheduler shall be present at the Preconstruction Schedule Meeting, prepared to discuss, in detail, the proposed sequence of work and methods of operation, and how that information will be communicated through the Progress Schedule. The Project Scheduler shall attend all meetings, or receive meeting minutes that outline schedule related issues of those meetings, which may affect the CPM schedule, including but not limited to those between the Contractor and their Subcontractors and between the Contractor and the Department. The Project Scheduler shall be knowledgeable of the status of all aspects of the work throughout the length of the Contract, including but not limited to: original contract work, additional work, new work, and changed conditions of work.

### **B. Scheduling Software:**

The State will provide Primavera P6 software, or newer release, and computer system for use by the Engineer to review the schedules submitted by the Contractor. The Department has installed Primavera P6 software, or newer release, on internet accessible servers for use by the Department’s construction inspection staff. Appropriate Department personnel, Consultants, and Contractors will also have access to these schedules on the Department’s Enterprise Project Management Database (EPMD). The Department will determine the location to store the project schedule files on the EPMD, and will provide the Contractor the naming convention for all progress schedule submissions.

The Contractor shall submit Request for Access Forms to the Regional Construction Engineer for each proposed Primavera user to obtain the User ID’s and Passwords for access to software and data on the Department’s network servers. The form can be downloaded from the following web page <https://www.nysdot.gov/main/business-center/contractors/construction-division/primavera>, or can be provided by the Department’s Construction Supervisor. These forms may submitted any time following the contract letting date and announcement by the Department that the Contractor is the apparent low bidder. The Department will process these requests and should generally provide the User ID’s and Passwords within two weeks of receipt by the Regional Construction Engineer. Upon approval and authorization by the Regional Construction Engineer, required User ID’s and passwords will be provided to the Contractor (for the Project



**ITEM 639.10220001 – CPM (CRITICAL PATH METHOD) PROGRESS SCHEDULE - Type 2**

Scheduler plus one other person) to obtain secure Internet access to the Primavera software and project schedule data. If the Contract is not awarded to this Contractor, the Contractor’s access to this project will be removed. Department provided User Id’s and Passwords are assigned to specific individuals and shall not be shared with any other users.

The Department will provide the Contractor either a Preliminary Construction Schedule or a project schedule template for the Contractor’s use in developing their CPM Progress Schedule. The Contractor shall develop, update, and revise the Progress Schedules using Primavera P6 software that has been loaded on the Department’s network servers and the Contractor shall store all Progress Schedule files on the Department’s network servers.

The Department will generally not “Import” or accept Progress Schedule files from any other computer system. However, the Department may consider a request to Import a Baseline Progress Schedule developed by the Contractor prior to the contract Letting Date using Primavera P6 that meets the requirements of this specification, if the request is made by the apparent low bidder to the Department within two weeks of the Letting Date with a copy of the file attached. The schedule file shall not contain any User Defined fields, all Calendars assigned to activities must be project level Calendars not Global or Resource Calendars, all Activity Codes shall be project level and not Global or EPS level Activity Codes, no Resources shall be assigned to activities, and no Project Codes shall be assigned.

Access rights within the Primavera network solution will be created and maintained by the Department. As this software is an enterprise application, the Department will be the sole entity to modify the EPS structure, the OBS Structure, Project Codes, Global Activity Codes, Global Calendars, User Defined Fields, Security Profiles, Admin Categories, and Admin Preferences.

<b>TABLE 1 – Schedule Filename convention</b>			
<b>Progress Schedules</b>	<b>1<sup>st</sup> Version</b>	<b>2nd Version</b>	<b>3rd Version</b>
Initial Baseline Progress Schedule	D26#####-1IB	D26#####-2IB	D26#####-3IB
Baseline Progress Schedule @ Award	D26#####-1BPS	D26#####-2BPS	D26#####-3BPS
Final Baseline Progress Schedule @ Award	D26#####-1FB	D26#####-2FB	D26#####-3FB
Month #1 Progress Schedule Submission	D26#####-1SU1	D26#####-2SU1	D26#####-3SU1
Month #2 Progress Schedule Submission	D26#####-1SU2	D26#####-2SU2	D26#####-3SU2
As-Built Progress Schedule (Last Progress Schedule)	D26#####-1AB	D26#####-2AB	D26#####-3AB
1 <sup>st</sup> Time Impact Analysis	D26#####-1TIA1	D26#####-2TIA1	D26#####-3TIA1
1 <sup>st</sup> Recovery Schedule	D26#####-1RS1	D26#####-2RS1	D26#####-3RS1

Primavera software and schedule data on the Department’s EPMD will generally be available for the Contractor’s use at all times unless system maintenance (i.e. backups, upgrades, etc) is being performed. System maintenance will generally be conducted over short time periods between the hours of 10 PM – 6AM, Monday - Friday and on weekends. The Department does perform regular backup of data contained in the EPMD, and will make every effort to restore the latest historical copy of schedule submissions in the event of any data failure of the EPMD. The Contractor shall also be responsible for exporting copies of project progress schedules, recovery schedules, TIA schedules, after data modifications have been made as their backup of these submissions. In the event a Contractor’s authorized user cannot access the software from 6AM to 10PM Monday through Friday, the Contractor shall provide written notification to the Engineer.

Project schedules are developed from the Contractor’s knowledge of the project, and the means and methods represented in those schedules are based on the Contractor’s understanding of the contract documents, and the Contractor’s past experience, which are unique to the Contractor. Schedule activity data and logic are therefore the intellectual property of the Contractor and will not be made available to other Contractors. All other schedule data, and all Enterprise data residing on the network servers, are the sole property of the Department.

**C. Preconstruction Schedule Meeting:**

The Contractor shall contact the Regional Construction Engineer after notification they are the apparent low bidder, but no later than two (2) State Business Days following the notice of contract award to schedule a Preconstruction Schedule Meeting. The purpose of this meeting will be to discuss all essential matters pertaining to the satisfactory scheduling of project activities, and to resolve any known questions regarding interpretation of the contract requirements for this work.

The Project Scheduler shall be prepared to discuss the following:

1. The proposed hierarchical Work Breakdown Structure (WBS) for the Progress Schedules. The Project Scheduler shall provide a paper copy at the meeting.
2. The proposed project calendars.
3. The proposed project activity codes, and various code values for each activity code. The Project Scheduler shall provide a paper copy at the meeting.
4. Specifics of any contract Time-Related Clauses (A+B Bidding, Incentive/Disincentive, Liquidated Damages, Lane Rental, etc.);
5. The Contractor's schedule methodology to be employed, proposed work sequence and any proposed deviations from the contract plans with respect to Staging or Work Zone Traffic Control phasing.
6. The Key Plans shall be provided at the meeting.
7. The factors that the Contractor determines to control the completion of the project and any milestone activity completion dates contained therein.
8. The Project Scheduler shall provide an outline for the content of the Narrative report for future Progress Schedule submissions.
9. Schedule submission protocol for Final Baseline Progress Schedule @ Award and Monthly Progress Schedule submissions.

The Engineer will be available to answer questions regarding scheduling, including: the availability of Department supplied electronic file(s) containing sample project schedule information, sample progress schedule narratives, Special Notes for CPM Scheduling, and required standard format for CPM Progress Schedules for contract work.

The Contractor shall schedule meetings as necessary with the Engineer to discuss schedule development and resolve schedule issues, until the Final Baseline Progress Schedule @ Award is accepted by the Engineer.

The Contractor is encouraged, but not required, to submit an Initial Baseline Progress Schedule that demonstrates a sample of how the Project Scheduler's proposed alphanumeric coding structure and the activity identification system for labeling work activities in the CPM progress schedule will conform to the detailed requirements of this specification. The review and comment by the Engineer of the sample schedule should assist the Project Scheduler in assuring the first submittal of the Baseline Progress Schedule @ Award will be in general conformance with the requirements of the specification and other contract requirements, and that major rework of the Baseline Progress Schedule @ Award will not be required. This submission shall reflect the Contractor's anticipated plan to complete the contract work in accordance with the contract documents, as envisioned by the Contractor at the time of contract bid. This submittal may be made anytime following notice to the Contractor that they are the anticipated low bidder on the contract. Critical items for this review should include but are not limited to: the proposed WBS for subsequent progress schedules; the proposed project Calendars; project Planned Start date; project Must Finish By date; major milestone activities (i.e. - Award, Notice to Proceed, Contract Completion); and between fifty to one hundred summary activities for the major work deliverables of the contract (i.e. - pave EB from STA x to STA y, construct roundabout 1, construct bridge xyz, etc) that have assigned Activity Ids, Activity Descriptions, Activity Durations, Predecessors, Successors, and Activity Relationships. These summary activities will be broken down into, or supplemented with, individual work activities for the baseline submission. If any Crew resources are included, the composition of the staffing (the number and titles of the various staff) shall be

**ITEM 639.10220001 – CPM (CRITICAL PATH METHOD) PROGRESS SCHEDULE - Type 2**

listed in the Notes tab of the Crew resource, and the composition of the crews shall be included in the narrative. To the extent practicable, the Initial Baseline Progress Schedule should include administrative and procurement activities to be accomplished during the contract; planned submittal, review, and approval dates for shop drawings, working drawings, fabrication drawings, and contractor supplied plans, procedures, and specifications.

If the Contractor proposes deviations to the construction staging or Work Zone Traffic Control Plans shown on the contract documents, then the Contractor must present a second Baseline Progress Schedule submission that reflects these proposed changes.

Any submission of a Initial Baseline Progress Schedule should be accompanied by a written Narrative that provides details of the Calendar assignments of working days versus non-working days, outlines the sequence of planned operations to complete the project work, and provides the proposed Activity Codes and Code values to be assigned to activities in future submissions of project progress schedules. The Engineer will review the logic diagram, coding structure, activity identification system, and Narrative; and provide comments for required changes by the Project Scheduler for implementation in the submission of the Baseline Progress Schedule @ Award. The Engineer will provide written comments on major deficiencies within five (5) State Business Days of receipt.

The Department reviews Initial Baseline Progress Schedules solely for format, and will not consider any submission of an Initial Baseline Progress Schedule for approval as an Early Completion Schedule.

The Contractor shall schedule meetings as necessary with the Engineer to discuss schedule development and resolve schedule issues, until the Baseline Progress Schedule at Award is accepted by the Engineer.

**D. Progress Schedule:****1. General**

In addition to the attributes of the Progress Schedule provisions as set forth in §108-01, the Contractor shall prepare, furnish, and maintain a computer-generated Progress Schedule using the Critical Path Method (CPM) utilizing Primavera scheduling software on the Department's network servers. The CPM Progress Schedule shall be prepared based on the principles defined by the latest issue of the Construction Planning & Scheduling Manual published by the Associated General Contractors of America, except where superseded by the contract documents such as the CPM Special Notes and this specification.

The Contractor and the Department shall use the Progress Schedule to manage the work, including but not limited to the activities of subcontractors, fabricators, the Department, other involved State agencies and authorities, other entities such as utilities and municipalities, and all other relevant parties involved with the project.

No work other than installation of the Engineer's Field Office, mobilization, procurement and administrative activities, installation of construction signs, installation of erosion and pollution protection, clearing and grubbing, field measurements, and survey and stakeout will be permitted to start until the Baseline Progress Schedule @ Award has been submitted to the Engineer, and the Engineer determines there are no deficiencies consistent with those identified in paragraph E.1.

The Contractor will be the sole entity allowed to physically modify the following data within the progress schedule: activity IDs; activity descriptions; activity durations; relationships between activities; successors and predecessors, actual start and actual finish dates of activities; planned start and planned finish dates of

## ITEM 639.10220001 – CPM (CRITICAL PATH METHOD) PROGRESS SCHEDULE - Type 2

activities; and activity resources (with the exception that activities assigned resources labeled to reflect Department personnel may be changed to reflect specific individuals, or job roles, within the Department).

The Department may modify certain data associated with the progress schedule to ensure conformance to the Department's Enterprise Project Management standard schedule format. This means that the Department may: create additional layouts, filters and reports; create and edit additional user defined custom data fields; assign Project Codes; add and assign additional project Activity Codes; add and assign additional Cost Account Codes; add and assign additional Resource Codes; enter data in Notebook tabs; modify calendar ID's (although not the calendar itself); etc; that do not alter the established activities or schedule logic of the Contractor. The Engineer shall communicate to the Project Scheduler the types and scope of changes planned to be made to the progress schedules prior to the implementation of those changes. The Contractor shall not delete or modify any schedule data entered by the Department without prior approval by the Engineer. The schedule data added by the Department shall be incorporated into future schedule submissions of the Contractor.

The Contractor shall develop the Progress Schedule using, to the maximum extent practicable, the Global Activity Codes (DOT GLOBAL) and Resources (NYSDOT Pay Item Resources) identified in the Department's Primavera enterprise solution. Any schedule "Layouts", "Filters" and "Report" formats that the Contractor develops for the various Progress Schedules submissions to the Engineer shall be saved and made available to all other users of the project schedule with a name that includes the contract D#.

The Department may make copies of the progress schedules to perform what-if type analysis, which may involve any type of modification to those copies of the schedules.

The purpose of the Progress Schedule shall be to:

- ensure adequate planning and staffing during execution of the work by the parties to the contract;
- ensure communication and coordination of activities among all affected parties;
- assist the Contractor and the Department in monitoring the progress of the work, and evaluating proposed changes to the contract and/or requests for additional time to project completion;
- establish a standard methodology for time adjustment analysis based on the principles of the Critical Path Method of scheduling, for use in time-related dispute resolution;
- determine appropriate extensions or reductions of Contract Time.

In scheduling and executing the work, the Contractor shall:

- a) Sequence the work commensurate with the Contractor's abilities, resources and the contract documents. The scheduling of activities is the responsibility of the Contractor.
- b) Ensure that Progress Schedules prepared by the Project Scheduler for submission to the Department are in compliance with the Contract. The intent should be that Schedule submissions and accompanying Narratives are timely, complete, accurate, and in compliance with the Contract.
- c) Communicate all Contract changes, and decisions or actions taken by the Contractor and all subcontractors, fabricators, etc, that effect the Progress Schedule to the Project Scheduler in a timely manner to allow appropriate development, maintenance, and update of the Progress Schedule.
- d) Include all work contained in the Contract and all work directed in writing by the Engineer. Work activities directed by the Engineer to be added to the Contract shall be included in the next Monthly Progress Schedule submission.
- e) Assure that Progress Schedule Updates reflect the actual dates that work activities started and completed in the field.
- f) Break a schedule activity into multiple activities to reflect a discontinuity in the work if a work activity is suspended in the field and restarted at a later date, and the break between when the work was suspended to when it was resumed is significant compared to the original activity duration.

**ITEM 639.10220001 – CPM (CRITICAL PATH METHOD) PROGRESS SCHEDULE - Type 2**

- g) Ensure the Progress Schedule contains all work constraints and Milestones defined in the Contract.
- h) Schedule the work using such procedures and staging or phasing as required by the Contract. Work designated as part of separate stages may be performed concurrently with other stages where allowed by the Contract or where approved by the Department.

Failure by the Contractor to include any element of work required by the Contract in the accepted progress schedule does not relieve the Contractor from its responsibility to perform such work.

Errors or omissions on schedules shall not relieve the Contractor from finishing all work within the time limit specified for completion of the contract.

**2. Baseline Progress Schedule @ Award**

- a) The Contractor shall ensure the schedule accurately reflects the proposed approach to accomplish the work outlined in the Contract documents and conforms to all requirements of this specification.
- b) The schedule shall define a complete logical plan that can realistically be accomplished, to execute the work defined in the Contract.
- c) The schedule shall comply with the work constraints and milestones defined in the Contract as well as all other contractual terms and conditions. The schedule shall be consistent in all respects with the specific interim Time-Related Contract Provisions, and any order of work requirements of the contract documents. The schedule shall meet all interim milestone dates and shall not extend beyond the contract completion date. This submission shall reflect the Contractor's plan at the time of contract award, and prior to the start of any work. No negative float is allowed in the Baseline Progress Schedule @ Award submission.
- d) Detailed Schedule Requirements - As a minimum, the Contractor shall address the following in the Baseline Progress Schedule:
  - i) Defining Project details and defaults – Within the Dates tab, the “Planned Start” shall be either the Letting Date or the contract Award Date, the “Data Date” shall be the date of Contract Award, the “Must Finish By” date shall be the contract Completion Date. Within the Settings tab, define the Critical Activities as the “Longest Path”. The Project Scheduler role does not have security privileges to change this data in the project Details tab, so requests for changes to this data needs to be forwarded to the [CPMSchedulingSection@dot.state.ny.us](mailto:CPMSchedulingSection@dot.state.ny.us); include in your request the contract Dnumber and the ProjectID.
  - ii) Sufficient activities shall be included to assure that there is adequate planning for the entire project. The appropriate number of activities will be largely dependent upon the nature, size, and complexity of the project. In addition to all site construction activities, network activities shall include: activities necessary to depict the procurement/submittal process including shop drawings and sample submittals; the fabrication and delivery of key and long-lead procurement elements; testing of materials, plants, and equipment; settlement or surcharge periods activities; sampling and testing period activities; cure periods; activities related to temporary structures or systems; activities assigned to subcontractors, fabricators, or suppliers; erection and removal of falsework and shoring; major traffic stage switches; activities assigned to the Department and other involved State agencies and authorities, including final inspection; activities to perform punch list work; and activities assigned to other entities such as utilities, municipalities, County government/agencies, and other adjacent contractors. The schedule shall indicate intended submittal dates, and depict the review and approval periods as defined in the Contract Documents for Department review.

The following activities shall be incorporated into the Progress Schedule:

## ITEM 639.10220001 – CPM (CRITICAL PATH METHOD) PROGRESS SCHEDULE - Type 2

Activity ID	Activity Description	Duration (Min)	Follows	Logic Tie	Responsibility
00001	Contract Letting Date	0 - Start Milestone	----	SS	NYSDOT
00005	Preconstruction Schedule Meeting	1 Working Day	00001	SS	NYSDOT
00010	Preconstruction Meeting	1 Working Day	00001	SS	NYSDOT
00011	DMWBE Goals Submitted		00001	SS	Contractor
00015	DMWBE Goals Approved	15 Working Days	000011	FS	NYSDOT
00020	Contract Award Process	45 Calendar Days	00001	SS	NYSDOT
00025	Contract Award Date	0 - Finish Milestone	00020	FF	NYSDOT
00030	Submit Proof of Insurance	1 Working Day	00001	SS	Contractor
00035	Notification to Proceed	1 Working Day	00025, 00030	FS	NYSDOT
00040	Submit Safety & Health Plan	1 Working Day	00001	SS	Contractor
00045	Approve Safety & Health Plan	20 Working Day	00040	FS	NYSDOT
00050	Contractor Starts Contract Work	0 - Start Milestone	00035, 00045	FS	Contractor
00055	Set Up Engineer's Field Office		00035	FS	Contractor
00060	Prepare & Submit Baseline Progress Schedule @ Award	See Note 1	00005	FS	Contractor
00065	Review Baseline Progress Schedule @ Award	See Note 2	00060	FS	NYSDOT
00070	Accept Baseline Progress Schedule @ Award	1 Working Day (see Note 3)	00065	FS	NYSDOT
00075	Mobilization	20 Working Days	00050	SS	Contractor
00100	Field Work Begins	0 duration	00050, 00055, 00060		Contractor
09000	Substantial Completion	0 duration	See definition	FS	Contractor
09010	Other Agency Inspection	20 Working Days	09000	FS	Others
09020	NYSDOT Inspection	20 Working Days	09000	FS	NYSDOT
09030	Punchlist work	20 Working Days	09020	FS	Contractor
09040	Demobilization	10 Working Days	09020	FS	Contractor
09100	Project Acceptance by the Engineer	0 duration	09040	FS	NYSDOT

Note 1 – Use Timeframe required in Table 2 column 1 of specification for Item 639.1022 xx.

Note 2 – Use Timeframe required in Table 2 column 2 of specification for Item 639.1022 xx.

Note 3 – Acceptance Date should not exceed Timeframe from Notice of Award required in Table 2 column 3 of specification for Item 639.1022 xx.

ITEM 639.10220001 – CPM (CRITICAL PATH METHOD) PROGRESS SCHEDULE - Type 2

The Logic Tie shown shall be used as a relationship to the predecessor activities contained in the column named Follows.

iii) **Work Breakdown Structure (WBS)** - A multi level hierarchal WBS shall be incorporated. The levels (nodes) shall include, but not be limited to:

- Level 1 - is the project level;
- Level 2 - shall have three nodes; Preconstruction Activities, Construction Activities, and Post Construction Activities;
- Level 3 - Preconstruction activities shall have two sub nodes; Submittals/Shop Drawing Activities, and Procurement /Fabrication Activities);
  - Construction activities shall be broken into nodes for various geographic “Areas” of work within the project limits;
- Level 4 - the Areas of work shall have sub nodes for the various Stages of work;
- Level 5 - the Stages of work shall have sub nodes for the various highway features: bridges, highway segments, interchanges, intersections/roundabouts, etc;
- Level 6 - the highway features should be broken into their components (a bridge into components such as Piles, Substructure, Superstructure), and a highway segment into components such as pavement, drainage, earthwork, lighting, traffic signals, etc.

An example Work Breakdown Structure is shown below in Figure 1

FIGURE 1

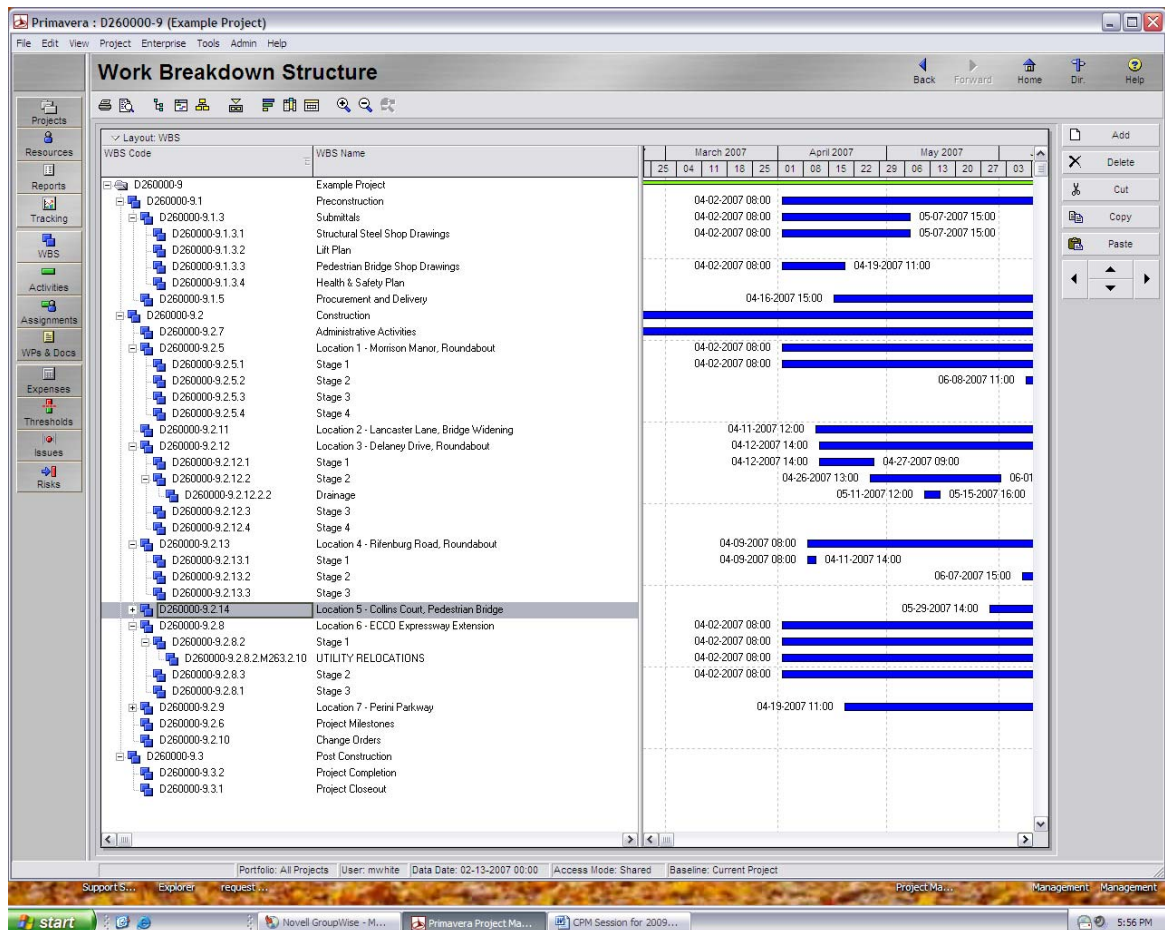

## ITEM 639.10220001 – CPM (CRITICAL PATH METHOD) PROGRESS SCHEDULE - Type 2

- iv) **Activity ID** - Include a unique identification number for each activity. Activity ID numbers shall not be changed, or reassigned.
- v) **Activity Name** - Clearly and uniquely define each activity name with a description of the work that is readily identifiable to inspection staff and the progress of each activity can be measured. Each Activity shall have a narrative description consisting at a minimum of a verb or work function (i.e. form, pour, excavate, etc), an object (i.e. slab, footing, wall, etc), and a location (i.e. STA, bridge or retaining wall number, street, etc). The work related to each Activity shall be limited to one Area of the contract, one Stage of the contract, one WZTC Phase of the contract, and one Responsible Party of the contract.
- vi) **Milestone Activities** - Include activities for all contract milestones that define significant contractual events such as Contract Award, Notice to Proceed, Contractor Start Work, Substantial Completion, Physical Completion, Contract Completion, and coordination points with outside entities such as utilities, State agencies, Authorities, municipalities, Time-Related Contract Provisions, etc.
- All milestone activities in the schedule shall be assigned the standard Global calendar named "NYSDOT Milestone/Curing 365 Day / 8 hour", this calendar should also be assigned to any activities for concrete curing.
- The Contract Award milestone shall have a primary constraint of "Finish On" and the date of Contract signature by the State Comptroller,
  - The Contract Completion milestone shall have a primary constraint of "Finish on or before" and the contract Completion Date.
  - The Contractor Start Work" Start milestone activity, that will eventually reflect the actual date the Contractor started work authorized under the contract.
- vii) **Activity Durations** – Define the Original Duration of each activity in units of whole work days, except for activities of less than one day duration which should be shown in units of tenths of a day. Except submittal/procurement activities, durations shall not exceed 15 work days unless approved by the Engineer. Durations for Department submittal reviews shall meet the requirements set forth in the contract documents. If requested by the Engineer, the Contractor shall justify the reasonableness of planned activity time durations.
- viii) **Activity Relationships** - Clearly assign predecessors and successors relationships to each activity, and assign appropriate logic ties between activities (Finish to Start, Start to Start, Finish to Finish, etc). Do not have any open ended activities, with the exception of the first activity and last activity in the schedule. An activity may only appear once as a predecessor or successor to another specific activity, but may be assigned as a predecessor or successor to many different activities. Do not include inappropriate logic ties with Milestone activities (i.e. – a finish milestone activity, and a predecessor assigned with a Finish to Start logic tie; or a start milestone, and a successor assigned with a Finish to Start logic tie). Lag time may not exceed 10 days. The Contractor shall not use negative Lag times.
- ix) The Contractor shall assign the "Contract Award Date" activity as a predecessor to all Review and Approval type activities to be performed by Department staff.
- x) **Activity Constraint Dates** – The Contractor shall not have any constrained activities, with the exception of contractual dates, unless the Engineer accepts such constraints in writing. Milestone activities shall be included for the Contract Award which shall have a primary constraint of "Finish On" and the date of contract signature by the State Comptroller, and for the Contract Completion which shall have a primary constraint of "Finish on or before" and the contract completion date indicated in the contract documents. Only contractual/owner-designated constraints are allowed unless specifically authorized by this specification or the Engineer.
- xi) **Activity Dates** – With the exception of contract Milestone dates, "Actual Start" and "Actual Finish" dates and "Planned Start" and "Planned Finish" dates, activity dates shall be calculated by the project scheduler tool within the Primavera software. No Actual Start or Actual Finish dates



## ITEM 639.10220001 – CPM (CRITICAL PATH METHOD) PROGRESS SCHEDULE - Type 2

shall be entered in the Baseline Progress Schedule @ Award, with the exception of activities that were completed prior to the Contract Award.

- xii) **Calendars** - Use clearly defined calendars that account for expected seasonal weather conditions (including winter shutdown periods) and environmental permit requirements, for the planning and scheduling of activities. Do not incorporate an activity with a description of “Winter Shutdown” that requires constraints. Provide the working days per week, holidays, the number of shifts per day, and the number of hours per shift by using the Calendar modifier in the P6 software. Incorporate any seasonal restrictions to the work within calendars assigned to activities.
- Calendars related to specific resources (i.e., a specific person or piece of equipment) shall be established as Resource Calendars, with the Calendar name clearly identifying the resource.
  - All other calendars developed by a Contractor shall be established as Project Calendars, with the calendar name including the contract D# and describing the function (i.e., D260000 - Asphalt Calendar, D260000 - Concrete Calendar, D260000 - Landscape Calendar, D260000 - Painting Calendar, D260000 – Contractor’s 5 Day/8 Hour Workweek). All work activities of the Contractor shall be assigned to Project Calendars.
  - Any Global calendars used in the progress schedule shall be those established by the Department. There are only two Global Calendars developed and maintained by the Department for use by Contractor’s, they are the following:
    - NYSDOT Milestone/Curing 365 Day / 8 hour
    - State Business Days, 5 Day Work Week w/State Holidays, Field
 Changes desired for these calendars shall be forwarded to [CPMSchedulingSection@dot.state.ny.us](mailto:CPMSchedulingSection@dot.state.ny.us), and if appropriate these changes will be performed by the Office of Construction system admin staff. This will be accomplished by making a copy of the existing Global calendar, then the new calendar will be renamed and modified as necessary.
  - Activities for shop drawing reviews and other approvals by Department personnel shall be assigned the Department’s standard Global – “State Business Day, 5 Day Work Week w/State Holidays, Field” Calendar that reflects all holidays observed by the State.
- xiii) Clearly define significant interaction points between the Contractor, the Department, and other entities including but not limited to: Federal, State and local agencies/authorities; and utilities. All activities of the Department, utility companies, adjacent contracts, and other entities that affect progress and influence any contract required dates including durations shall be shown in the schedule. This includes dates related to all Permits or Agreements. The schedule shall give special consideration to sensitive areas such as road closures and parklands and shall indicate any time frames when work is restricted in these sensitive areas as outlined in the permits issued by the regulatory agencies, and provided in the contract documents.
- xiv) **Activity Resources** – The Contractor will generally not be required to develop Labor resources, Equipment resources or Contract Pay Item resources in the Resource Dictionary, or assign them to schedule activities. The Contractor may be required by the Engineer to assign Labor and Equipment resources if submitting a Progress Schedule when contract milestone activities are projected to have Early Completion dates, as described in paragraph I of this specification. The Contractor will not be required to assign costs to resource assignments in the schedule. The Department will assume when reviewing the schedule that the Contractor’s resources are unlimited; unless the Contractor either assigns equipment, labor and contract pay item resources to each activity in the schedule (and performs resource leveling), or indicates in the schedule narrative what resource limitations are present. If labor, equipment and contract pay item resources are not assigned to activities in the schedule, it shall be the Contractor’s responsibility to assure the activity logic in the schedule properly reflects their resource limitations. If labor and equipment resources are not assigned to activities in the schedule, and the Contractor anticipates multiple crews for the same schedule activity, these resources shall be documented in

## ITEM 639.10220001 – CPM (CRITICAL PATH METHOD) PROGRESS SCHEDULE - Type 2

the schedule narrative. As an activity can have only one responsible party, no activity shall involve multiple crews comprised of the Contractor and a subcontractor, or multiple subcontractors.

- xv) **Activity Codes** – The Contractor shall include a well-defined activity coding structure that allows project activities to be sorted and filtered. Activity Codes shall include, but not be limited to: Responsible Party; Stage; Area of Work; Type of Work; Subcontractor; and additionally as required by the Engineer to meet the needs of the specific contract work to facilitate the use and analysis of the schedule.
- No Global Activity Codes shall be incorporated in any progress schedule submission to the Engineer except those established by the Department.
  - The Global activity codes established by the Department shall be used to the maximum extent practicable. The Contractor shall assign the appropriate activity code values to each activity in the progress schedule for the following Global Activity Codes that are in the Department’s enterprise database:
    - 1) RESPONSIBLE PARTY (DOT GLOBAL)
    - 2) STAGE (DOT GLOBAL)
    - 3) AREA (DOT GLOBAL)
    - 4) TYPE OF WORK (DOT GLOBAL)
    - 5) PAY ITEM (DOT GLOBAL)
    - 6) CHANGED (ADDED/DELETED) WORK (DOT GLOBAL)
    - 7) TIME Related Clauses (DOT GLOBAL)
    - 8) DELAY (DOT GLOBAL)
  - Additional Activity Codes developed for specific projects shall be established as Project Activity Codes.
- xvi) **Activity Code Values** – Each Activity Code shall be broken down into various Activity Code Values that are then assigned to activities. For example, the Activity Code “Stage” shall include a hierarchal arrangement of Activity Code Values as shown below in Figure 2:

FIGURE 2

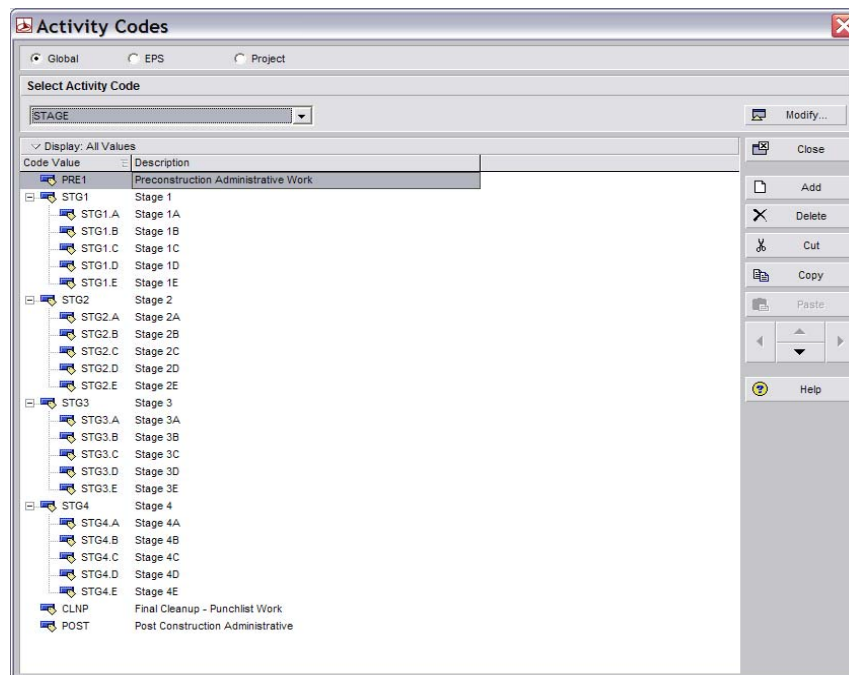

## ITEM 639.10220001 – CPM (CRITICAL PATH METHOD) PROGRESS SCHEDULE - Type 2

- xvii) **Activity Code Assignments** - For each activity, within the activity details the Contractor shall assign Activity Code values to identify the “Responsible Party” (i.e. – Contractor, NYSDOT, Utility Co, Municipality) for the work to be performed (one and only one responsible party shall be assigned to each activity), the “Stage” of the contract for the work that will be performed, the “Area” where the work is to be performed, the “WZTC Phase”, and the Type of Work (i.e. - Procurement, Paving, Embankment, Excavation, Electrical, Signing, etc). For activities included in work governed by time-related contract provisions, the appropriate “Time Related” activity code shall be utilized. For activities included in work added and/or changed within an Order-On-Contract, the appropriate “Added/Changed Work” code shall be utilized. For all work activities performed by the Contractor or subcontractors/fabricators/suppliers, “Contractor” shall be designated as the Responsible Party. If the Contractor wants a separate activity code to enable sorting the activities of subcontractors, fabricators, or suppliers a separate “Subcontractor” code shall be utilized.
- xviii) **Interim Milestone Dates with Liquidated Damages and Special Time-Related Contract Provisions** (i.e. – A+B Bidding, Incentive/Disincentive provisions, Lane Rental) – Each time-related contract provision in the contract shall be represented in the progress schedule by having a start and finish milestone, with appropriate predecessors and successors assigned to all schedule activities considered part of that time-related contract provision work including the start and finish milestone activities. In addition, the Start milestone for the time-related contract work shall have predecessors and/or date constraints assigned that include those defined in the contract documents, and the Finish milestone for the time-related contract work shall have successors and/or date constraints assigned that include those defined in the contract documents. All schedule activities associated with each specific time-related contract provision shall be assigned to a separate node within the project WBS and the WBS node description shall be labeled accordingly, in addition these activities shall be assigned the appropriate Time-Related Clauses (DOT GLOBAL) activity code value. A Level Of Effort activity shall be used for each time related contract provision (i.e - “Incentive 1 Duration” or “B Clock 1 Duration”), this activity shall have the Start Milestone as a predecessor with a SS relationship and the Finish Milestone as a successor with a FF relationship and the duration of this activity shall be calculated when the project is scheduled.
- xix) **Narrative** - Include a narrative in Microsoft Word and/or Adobe Acrobat format that describes:
- The Contractor’s general approach to construct the Work outlined in the baseline schedule. Address the reasons for the sequencing of work and describe any resource limitations, potential conflicts, and other salient items that may affect the schedule and how they may be resolved.
  - If not provided in the contract plans, or if modified by the Contractor, provide copies of the appropriate contract plan sheets marked up as Key Plans, to correlate values on the contract plans (for Area of Work, Stage of Work, and WZTC Phase) to the Contractor’s planned breakdown of the project (ie- Activity Codes, Activity Descriptions) for scheduling purposes.
  - The justification(s) for each activity with a duration exceeding 15 working days.
  - The reason for any lags assigned to any activities.
  - The justification(s) for Contractor imposed activity constraints proposed in the schedule.
  - A list of calendars which have been used in the schedule, along with the general reason for their use.
  - The project critical path and challenges that may arise associated with the critical path.
  - Anticipated coordination issues related to work activities by other entities, that require additional information from or action by the Engineer.
  - Appendix 1 to the narrative shall be the “Schedule Log” report created when the project was scheduled.

ITEM 639.10220001 – CPM (CRITICAL PATH METHOD) PROGRESS SCHEDULE - Type 2

- Appendix 2 to the narrative shall be an electronic schedule plot (Adobe Acrobat format) using the Global Layout named “Baseline Schedule submission”, with activities sorted by Start Date in ascending order, Grouping of activities by WBS, and only the “Longest Path” filter applied. This plot shall provide a clear critical path from the Data Date to the last activity in the schedule.
- xx) **List of Submittals** – The Contractor shall submit with the Progress Schedule a list of all Submittals (i.e. - Shop Drawings, required permits, Erection/Demolition plans, Health and Safety Plan, etc.) generated from the Baseline Progress Schedule for review and approval by the Engineer. The Contractor shall use a Filter to limit the schedule activities shown in the report to only the prepare/submit, and review/approve activities related to submittals. For construction contracts that utilize Primavera Contract Manager, Shop Drawing submittal activities in the Progress Schedule shall be at the Submittal Package level. The report shall be in Adobe PDF format and transmitted to the Engineer by email.
- e) **Schedule Submission**
- i) Within the timeframe indicated in Table 2 column 1, submit one electronic copy of the Baseline Progress Schedule @ Award in a Critical Path Method (CPM) format for the Engineer’s review and acceptance.

<b>TABLE 2 (in State Business Days)</b>		
<b>Timeframe from receipt of Notice of Award to Submission of complete Baseline Schedule. (Column 1)</b>	<b>Timeframe for Engineer’s Review (Column 2)</b>	<b>Timeframe from Notice of Award to acceptance by the Engineer not to exceed (Column 3)</b>
10	10	40

- ii) The Engineer will review the schedule and return it, accept it with comments, or reject it within the timeframes indicated in Table 2 column 2, following the date of receipt of the Contractor’s submission.
- iii) If the schedule is returned with comments, the Contractor shall address all comments and revise the schedule as necessary. The Contractor shall complete the Final Baseline Progress Schedule @ Award and obtain the acceptance of the Engineer within the timeframe required in Table 2 column 3.
- iv) If the schedule is accepted by the Engineer without any comments, the Contractor shall copy the schedule and rename it for submission as the Final Baseline Progress Schedule @ Award.
- v) In no way does the Baseline Progress Schedule modify the contract documents.
- vi) The Contractor shall assign appropriate Activity Codes and provide custom Layouts, Filters, and/or report formats necessary to allow the Engineer to generate a report from the each Progress Schedule submission of all submittals required under the contract (i.e., shop drawings, required permits, erection/demolition plans, etc). The list shall show scheduled submission date, review date, and acceptance date for each submittal and identify the earliest activity affected by each of these submittals. This list shall be generated from each Progress Schedule submission until all such activities are completed.

**3. Final Baseline Progress Schedule @ Award**

- a) If the Baseline Progress Schedule @ Award is returned to the Contractor with comments, the Contractor shall make a copy of the schedule and rename it as the Final Baseline Progress Schedule @ Award with comments addressed and revisions made as necessary. The Contractor shall complete the Final Baseline Progress Schedule @ Award and obtain acceptance of the Engineer within the

## ITEM 639.10220001 – CPM (CRITICAL PATH METHOD) PROGRESS SCHEDULE - Type 2

timeframe required in column 3 of Table 2, or within one week of the Contractor's receipt of the final comments by the Engineer, whichever is sooner.

- b) The Engineer shall review the schedule and return it, accepted or with comments, within 5 State Business days following the date of receipt of the Contractor's submission.
- c) The Final Baseline Progress Schedule @ Award must be "accepted" or "accepted as noted" by the Engineer prior to the Department evaluating any Contractor disputes associated with time impacts. This does not preclude the Contractor from submitting a dispute while the schedule is being reviewed for acceptance.

#### 4. Monthly Progress Schedule Submissions.

- a) First Monthly Progress Schedule Submission – Within three State Business Days following acceptance of the Final Baseline Progress Schedule @ Award or the closing date for the first months contract payment period whichever is later, the Contractor shall perform a Progress Schedule Update to reflect the status of all activities where work was performed in the time period between the start of work and acceptance of the Final Baseline Progress Schedule @ Award. This shall include actual dates entered in the Actual Start and Actual Finish columns, and percentage of work complete for uncompleted activities, in addition the Contractor shall incorporate any Progress Schedule Revisions that reflect any changes in how future work activities are to be completed.
- b) Subsequent Monthly Progress Schedule Submissions - On a monthly basis, the Contractor shall submit a copy of the current Progress Schedule that includes all Progress Schedule Revisions and Progress Schedule Updates to reflect the actual and planned prosecution and progress of the contract work. Progress Schedule Updates shall reflect the status of activities that have commenced or have been completed, including the following items: (a) actual dates in activity Actual Start and Actual Finish columns as appropriate; (b) actual Remaining Duration for activities commenced and not complete; and (c) actual activity Suspend or Resume dates for activities commenced and not complete. Progress Schedule Revisions reflect modifications made to activities in the current project baseline schedule in any of the following items: (a) activity Original Duration; (b) changes in logic connections between activities; (c) changes in Constraints; (d) changes to Activity Descriptions; (e) activity additions or deletions; (f) changes in Activity Code assignments; (g) changes in activity Resource assignments; and (h) changes in Calendar assignments. All "Out of Sequence" activities noted in the scheduling log shall be corrected to reflect the current construction operations.

When preparing a formal submission of the progress schedule, the Contractor shall make a copy of the current Progress Schedule and name it according to the file naming convention provided by the Department in Table 1.

- c) Additional Schedule Requirements - In addition to the schedule requirements detailed for the submission of the Baseline Progress Schedule @ Award, the following shall be provided by the Contractor:
  - i) Data Date - the "Data Date" shall be the date the Project Scheduler last edits the schedule prior to submission to the Engineer (generally the last working day of the contract payment period). The Project Scheduler can modify the project's Data Date through the Schedule tool.
  - ii) Activity Status -
    - a. Durations – the Original Duration shall not be changed without prior written justification by the Contractor, and written approval by the EIC. The Contractor shall edit the Remaining Duration to reflect progress made on work activities, and shall not use Duration % . If a proposed change to Original Duration is due to additional or changed work to the contract the Contractor shall instead add an activity to reflect this additional work, and assign the appropriate Activity Code.
    - b. Started and Finished dates – for each activity where work was started during the month, the Contractor shall enter the date the work Started. For each activity where work was completed during the month, the Contractor shall enter the date the work Finished.
    - c. Suspended work – The first time that work has been suspended on a schedule activity, the Contractor shall enter the Suspend and Resume fields within the Project Details under the

## ITEM 639.10220001 – CPM (CRITICAL PATH METHOD) PROGRESS SCHEDULE - Type 2

Status tab. For any subsequent suspensions of work to that activity the Contractor shall break that activity into two or more activities to accurately reflect the suspension and resumption of work dates in the field, and to more accurately reflect the relationship to other work activities.

- iii) Activity Resources – For each activity that resource limitations are affecting the prosecution of work, as determined by the Engineer, labor and equipment resources shall be entered in the schedule. Unit costs or pricing is not required. Labor Resources shall identify resources that encompass direct labor at the Crew level (i.e. – Grade Crew 1, Paving Crew 1, Pipe Crew 1, Bridge Footing Crew 1, Bridge Deck Crew 1, etc), the makeup of the Crew shall include the various Labor classes and equipment that comprise the Crew along with the quantity of each labor class and type of equipment. The Contractor shall provide the makeup of each Crew in the Schedule Narrative, and assign those Crews to the appropriate activities in the Progress Schedule. Equipment resources shall be shown for major or specialty equipment such as tower cranes, pile drivers, barges, asphalt pavers, concrete pavers, dozers, front end loaders, backhoes, rollers, excavators, graders, long line striping trucks or other equipment that cannot be rented easily.
- iv) Calendars – To change a project calendar for activities scheduled in the future, the Contractor shall copy the calendar and use a revised name that includes a reference to which Monthly Update the change was incorporated (i.e. - D260000 - Concrete Calendar should be revised to D260000 – 2 - Concrete Calendar to reflect the 2<sup>nd</sup> Monthly Update when the change was made to the calendar). The reason for the change in the calendar shall be documented in the Narrative.
- v) Notebook - For any activities on the critical path that are delayed, the Contractor shall enter the dates the activity was delayed and the reason for such delay in the Notebook tab of that activity.
- d) **Monthly Progress Schedule Narrative** - For each Monthly Progress Schedule submission, the Contractor shall submit a narrative in Microsoft Word, or Adobe Acrobat format that includes, but is not limited to: (The narrative may be an annotated copy of the Claim Digger Report that includes the information below.)
  - i) The contract D number, project name, project location, and name of Prime Contractor.
  - ii) Actual contract Award Date, current contract Completion Date, and scheduled completion of all project work.
  - iii) Any contact Interim Milestone dates (I/D, B-Clock, LD, etc), and scheduled Start and Finish dates for those Milestone activities.
  - iv) List all activities on the Critical Path (include Activity ID's and Activity Descriptions) where work is currently being delayed, and for each such activity provide detailed information including:
    - the events that caused the delay.
    - the party(s) responsible for the delay event(s).
    - the number of days the activity has been delayed (negative float).
    - the activities in the construction schedule affected by the events.
    - the reasonable steps needed to minimize the impact of the delay, and which party needs to take the action(s).
  - v) List any other problems experienced during this Progress Schedule submission period, the party responsible for the problems, and the Contractor's intentions to resolve the problems.
  - vi) List all activities for procurement of long lead time materials that are behind schedule and the reason(s) why.
  - vii) For major work items describe the differences between the actual work performed and the work planned for the period as represented in the preceding Progress Schedule submission, including explanations for the deviations.
  - viii) For all suspended work activities that could otherwise logically be progressed, identify the responsible party prohibiting the progression of the work, as well as the detailed reasons why.
  - ix) Description of any changes to the critical path since the last Monthly Progress Schedule submission and the impacts of such changes.

## ITEM 639.10220001 – CPM (CRITICAL PATH METHOD) PROGRESS SCHEDULE - Type 2

- x) Change to State Owned Float and/or Contractor Owned Float based on changes to the critical path.
- xi) List of all added or deleted activities included in this Monthly Progress Schedule submission, and the reason(s) for and the impact(s) of such changes.
- xii) List all changes in activity Original Durations, the justification for such change(s), and the impact(s) of such changes.
- xiii) List all changes in relationships between activities included in this Progress Schedule submission, and the reason(s) for and the impact(s) of such changes.
- xiv) List any addition or deletion of activity or project constraints, and the reason(s) for and the impact(s) of such changes.
- xv) List all changes to the project calendars, and the reason(s) for and the impact(s) of such changes.
- xvi) The major work elements, as defined in the WBS, to be accomplished during the next monthly work period.
- xvii) Any potential problems that are anticipated for the next monthly work period and the proposed solutions to such problems. Identify potential problems or risks that either the Department or Contractor may be potentially responsible for. Explain what action the responsible party (i.e. - Department or Contractor) needs to take and the date by which time the action needs to taken to avoid the problem.
- xviii) Any planned acceleration of activities that the Contractor anticipates to undertake within the next monthly work period that either the Department directed, or that the Contractor believes is necessary.
- xix) The following appendix in Adobe Acrobat PDF file format, formatted to fit ANSI Size D paper (610 mm x 914 mm) (24 inch x 36 inch) paper, shall be included with the narrative.
  - APPENDIX 1 – A listing of all work activities as of the data date, using the Classic Schedule Layout, sorted by Early Start Date, Total Float in increasing order, showing the Activity ID, Activity Description, Original Duration, Remaining Duration, Total Float, Early Start date, Early Finish date, Start date, Finish date, and Calendar ID. The grouping of activities shall be by Area, Stage, WZTC Phase, and Type of Work. The Gantt Chart shall clearly indicate the project critical (longest) path. Graphical representations shall be shown at a suitable scale to be legible and readable.  
The following appendices in Adobe Acrobat PDF file format, formatted to fit 216 mm x 279 mm size (8.5 inch x 11 inch) paper, shall be included with the narrative.
  - APPENDIX 2 – A complete Scheduling/Leveling Report (SCHEDLOG.TXT file generated by the Department’s Primavera scheduling software application) which includes the Schedule Settings, Statistics, Errors, Warnings, Scheduling/Leveling Results, Exceptions, Activities with unsatisfied constraints, Activities with unsatisfied relationships, and Activities with external dates. The statistics shall include, # of Activities, # of Activities Not Started, # of Activities In Progress, # of Activities Completed, # of Activity Relationships, and # of Activities with Constraints. Total number of activities on the critical path, percent complete, activities without predecessors, activities without successors, and activities out of sequence.
  - APPENDIX 3 – Claim Digger Report (generated by the Primavera software application) providing a comparison between this Progress Schedule submission and the previous Progress Schedule submission.
- e) The Contractor shall include a Time Impact Analysis (TIA) with any request for an extension of contract time.
- f) Schedule Submission - The Contractor shall submit the Monthly Progress Schedule to the Engineer monthly using the closing date for the monthly contract payment. The schedule submission to the Engineer shall be made within three (3) State Business Days of the Data Date, whether or not the Engineer has accepted the previous Monthly Progress Schedule submission. Schedule submittals will only be considered complete when all documents and data have been provided.

## ITEM 639.10220001 – CPM (CRITICAL PATH METHOD) PROGRESS SCHEDULE - Type 2

Immediately prior to submitting the schedule the Project Scheduler shall “Schedule” the project, when scheduling the project the Scheduling Options shown in Figure 3 shall be used unless approval to vary from these settings is given by the Engineer, or if the schedule has an Early Completion Date(s) as outlined in paragraph I of this specification the option to Level Resources during Scheduling shall be checked. The Project Scheduler shall use the same Scheduling Options for all Progress Schedule submittals for the duration of the contract, unless directed otherwise by the Engineer.

FIGURE 3

- g) Schedule Submission Method - The Contractor shall submit the schedule to the Engineer electronically for review and acceptance. The filename shall conform to the requirements of Table 1. The Project Scheduler can change the Project ID and Name through the WBS at the top node, as they do not have privileges to edit data through the Project Details tab. The Contractor’s submission shall be documented by an E-mail to the Engineer, with a copy to [CPMSchedulingSection@dot.state.ny.us](mailto:CPMSchedulingSection@dot.state.ny.us) and all appropriate project participants, that the project schedule on the network is ready for review. The Contractor’s E-mail to the Engineer shall also consist of the following:
- i) The subject of the E-mail shall include the Region #, contract D number, the Project Name, the Progress Schedule’s ProjectID, and construction company name. (i.e. – Region 8, D260000, Rehabilitation of Main Street viaduct, D260000-1UD2, ABC Contractors)
  - ii) The E-mail message shall include the name of the EIC, the current anticipated Finish date of the last activity in the project schedule, a statement as to how that date compares to the current Contract Completion Date, and the name of the Area Construction Supervisor.
  - iii) Electronic files of all Narrative Reports and required attachments associated with the schedule shall be submitted by the Contractor in Adobe Acrobat format.



## ITEM 639.10220001 – CPM (CRITICAL PATH METHOD) PROGRESS SCHEDULE - Type 2

**5. As-Built Progress Schedule.** The Contractor shall submit the As-Built Progress Schedule with Actual Start and Actual Finish dates for all activities, within ten (10) State Business Days following final acceptance of work by the Regional Director.

**6. Look-Ahead Schedule.**

Except during winter shutdown periods the Contractor shall prepare a Look-ahead Schedule as either a plotted report from the current progress schedule, or as a narrative report, and provide it to the EIC on a weekly basis, or if approved by the Engineer on a mutually agreed upon interval. The Look-ahead schedule shall include work activities planned for the next one or two week period, as determined by the Engineer, and shall include, but is not limited to: anticipated lane closures, road closures and detours, environmental issues, and utility issues. The Engineer will provide the Project Scheduler with guidelines for determining the begin dates and end dates for the one or two week reporting periods, along with the how the plotted schedule report or narrative report shall be formatted.

The Department generally uses this Look-ahead schedule to facilitate communication with other Federal or State agencies, local municipalities, utility companies, railroads, emergency service providers, public news media and other affected parties.

**E. Progress Schedule Review and Analysis:**

**1. Immediate Rejection of Progress Schedule Submissions.**

The following deficiencies in a Contractor's progress schedule submission shall be grounds for the immediate rejection by the EIC, without further review, analysis and/or comments.

- a) Failure of the Project Scheduler to "schedule" the project, as of the data date.
- b) Failure to attach a copy of the complete Scheduling/Leveling Report (SCHEDLOG.TXT file generated by Primavera software application).
- c) Any activities without predecessors, or activities without successors, appearing in the Scheduling/Leveling Report with the exception of the first and last activity in the schedule.
- d) Any activity constraints appearing in the Scheduling/Leveling Report that have not been approved in writing by the EIC, or that are not specifically allowed by this specification.
- e) Any Activities with Actual Dates > Data Date appearing in the Scheduling/Leveling Report.
- f) Any Milestone Activities with invalid relationships appearing in the Scheduling/Leveling Report.
- g) Failure to have a clearly defined Critical Path from the Data date to the last activity in the schedule, using the Longest Path method. This would reflect logic errors in the project schedule.
- h) Failure to attach the schedule Narrative and required appendices.
- i) Failure to attach the Claim Digger Report (generated by the Department's Primavera scheduling software application) providing a comparison between this Progress Schedule submission and the previous Progress Schedule submission. (Not required for baseline submissions)

If any of these deficiencies are found, the Contractor's submission shall be considered deficient, and Engineer will notify the Contractor immediately by return E-mail of the rejection of the schedule submittal.

If the Contractor fails to submit a CPM Progress Schedule conforming to the provisions required under this specification, to the degree that such failure is deemed by the Regional Construction Engineer to adversely affect the management of the project and/or the administration of the construction contract, liquidated damages will be assessed as determined under Basis of Payment.

**2. Schedule Analysis Method.**

Events, actions, and progress that cause delays or gains to the Progress Schedule will be analyzed solely by the "Contemporaneous Period Analysis" method.

## ITEM 639.10220001 – CPM (CRITICAL PATH METHOD) PROGRESS SCHEDULE - Type 2

**3. Project Progress Meetings.**

One topic of the regular progress meetings held by the Engineer and attended by the Contractor shall be a review of the Weekly Status Report generated from the Progress Schedule. The Contractor shall be represented by the Field Superintendent and Project Scheduler. The Project Scheduler shall bring a copy of the printed plot of the current Weekly Status Report to the progress meeting, the report shall show the current anticipated schedule for all remaining work with the critical path activities highlighted.

- a) The review of the Status Report serves as the forum to discuss project progress and delays, suggested remedies, necessary Progress Schedule revisions, coordination requirements, change orders, potential Contractor time extension requests, and other relevant issues. If contract work is falling behind the Progress Schedule, the responsible party (i.e.- Contractor or Department) shall be ready to discuss what measures it will take in the next thirty (30) days to put the work back on schedule so as to meet the contract Completion Date specified in the contract.
- b) Items of discussion will include, but are not limited to: project progress; schedule progress; near term and long-term schedule issues, including RFIs, Shop Drawing submittals, permit work, utility relocations, mitigation work; project issues and risks; proposed solutions; and any relevant technical issues that are schedule related.
- c) At the meeting the Project Scheduler shall compile an action item list that describes who is responsible for existing or pending issues and the date by which the issue needs to be resolved to avoid delays. The Contractor shall forward a copy of the action item list to the Engineer within 2 business days following the meeting.

**4. Department Review and Acceptance of Progress Schedules.**

The Engineer will review the Monthly Progress Schedule submissions and will prepare a written response (Progress Schedule Review Report) to the Contractor's submission within five (5) State Business Days following receipt of the Contractor's complete schedule submission. The Engineer will either "accept" the schedule, "accept as noted", or "reject" the schedule for re-submittal by the Contractor.

If the Progress Schedule submission is not in compliance with contract requirements, the Engineer may reject the submittal and shall forward any comments and requests for schedule revisions to the Project Scheduler with a copy to the Contractor. The Project Scheduler shall address all comments in writing and/or make the requested revisions, and resubmit the revised schedule within three (3) State Business days of the Engineer's reply. If the Engineer determines the revised submission still does not meet the contract requirements, any further revisions required thereafter shall also be submitted for acceptance within (3) business days of the request for revisions by the Engineer.

For schedules that are "accepted as noted" the Engineer shall forward any comments, or requests for revisions, to the Contractor. The Project Scheduler shall address all comments in writing and/or make the requested revisions as part of the next scheduled Progress Schedule submission.

The Project Scheduler shall make adjustments to the Progress Schedule in accordance with the Engineer's comments and resubmit copies for review consistent with the requirements of this section.

The Engineer, by accepting the progress Schedule, does not agree that the Progress Schedule is reasonable or that by following the Progress Schedule the Contractor can complete the work in a timely manner. If, after a Progress Schedule has been accepted by the Engineer, either the Contractor or the Engineer discover that any aspect of the Schedule is on error, or something significant has been omitted, the Contractor shall correct the Progress Schedule in the next Progress Schedule submission and describe this revision in the Narrative report.

Acceptance of progress schedules by the Engineer shall not be construed to imply approval of any particular construction methods or sequence of construction or to relieve the Contractor from its

**ITEM 639.10220001 – CPM (CRITICAL PATH METHOD) PROGRESS SCHEDULE - Type 2**

responsibility to provide sufficient materials, equipment and labor to guarantee the completion of the contract in accordance with the contract documents.

Acceptance of the progress schedule by the Engineer does not attest to the validity of assumptions, activities, relationships, sequences, resource allocations, or any other aspect of the progress schedule. Within the contractual constraints, the Contractor is solely responsible for the planning and execution of the work.

Acceptance of the progress schedule by the Engineer shall not be construed to modify or amend the contract agreement or the date of completion therein. Completion dates can only be modified or amended by standard contractual means, through an official HC-250b Request For Extension of Completion Date.

If any resources are included in the Progress Schedule, it is not intended that the Engineer, by accepting the schedule should use the Contractor's resource data for anything other than determining the reasonableness of achieving the Contractor's production rates. Resources included with the accepted CPM schedule shall not be misconstrued as a cost benchmark for the performance of planned or actual work.

Once the progress schedule has been accepted, the Contractor shall not deviate from it without first notifying the Engineer in writing.

Upon receipt from the Contractor of the corrected schedule, a new review period by the Engineer of five (5) State Business days will begin.

**F. Changes to Progress Schedule due to Added/Deleted/Changed Work:**

**1. Changes to the contract.** In the event a notice of a change to the contract is received, the appropriate changes to the progress schedule shall be made, as necessary, to incorporate the anticipated added/deleted/changed work and the Contractor shall notify the Engineer in writing within 10 (ten) calendar days if there is any effect of such change to the schedule. Change to the contract includes, but is not limited to, extra work, Agreed Prices, Orders on Contracts, Suspensions of Work Directed by the Engineer, Changed Condition, and Value Engineering Change Proposals. Added, deleted and/or extra work associated with Orders On Contract shall be reflected in the next Monthly Progress Schedule Submission in anticipation of and prior to the date in which the work physically takes place without regard to the dates when the actual Order On Contract was approved. The effect of the change to the contract on the projects Critical Path shall be stated. Extra work or additional work that does not affect the controlling operation on the critical path will not be considered as the basis for a time extension. All schedule activities effected by added, deleted or changed work that is included in a signed Order-On-Contract, Field Change Order, or Authorization of Extra Work (with the exception of minor quantity changes that do not impact contract milestones), or work activities performed by the Contractor at risk in anticipation of such Department approval, shall be assigned the appropriate Activity Code (Added/Changed Work) and Code Value (sequentially numbered) to denote which "Changed Contract Work" order number correlates to those activities of work.

**2. Time Impact Analysis.**

A Time Impact Analysis (TIA) shall be submitted to the Engineer for each request by the Contractor for an adjustment of contract time, or when the Contractor or Engineer consider that an approved or anticipated change to the contract may impact the critical path and contract progress by more than a calendar month. The TIA shall be based on a revised Progress Schedule and shall be submitted as an electronic file (using Microsoft Word for the narrative) containing:

## ITEM 639.10220001 – CPM (CRITICAL PATH METHOD) PROGRESS SCHEDULE - Type 2

- a) The TIA shall illustrate the impacts of each change or delay on the current scheduled completion date or internal milestone, as appropriate.
- b) The analysis shall use the accepted Monthly Progress Schedule that has a data date closest to and prior to the event as the “Current Baseline”, this shall then be compared against the “What-if Project Plan Baseline” for the purpose of the TIA.
- c) If the Engineer determines that the accepted schedule used does not appropriately represent the conditions prior to the event, the accepted schedule shall be updated to the day before the event being analyzed.
- d) The TIA shall include an impacted schedule (“What-if Project Plan Baseline”) developed from incorporating the actual or anticipated event into the accepted schedule by adding or deleting activities, or by changing durations or logic of existing activities.
- e) If the impact schedule shows that incorporating the event negatively modifies the critical path and scheduled completion date of the accepted schedule, and the Engineer accepts the impacted schedule, the difference between scheduled completion dates of the two schedules shall be equal to the proposed adjustment of contract time.
- f) The Engineer may construct and utilize an appropriate project schedule or use another recognized method to determine adjustments in contract time until the Contractor provides the TIA.
- g) The Contractor shall submit a TIA within fifteen (15) State Business Days of receiving a written request for a TIA from the Engineer.
- h) The Contractor shall allow the Engineer ten (10) State Business Days after receipt to accept or reject the submitted TIA. All accepted TIA schedule changes shall be included in the next Monthly Progress Schedule submission.
- i) If a TIA submitted by the Contractor is rejected by the Engineer, the Contractor shall meet with the Engineer to discuss and resolve issues related to the TIA. If agreement is not reached, the Contractor will give notice in conformance with §104-06 Notice & Recordkeeping, and submit in accordance within the provisions in §105-14.E "Required Content of *Dispute Submissions*".
- j) The Contractor shall only show actual as-built work, not unapproved changes related to the TIA, in subsequent Monthly Progress Schedules submissions. If agreement is reached at a later date, approved TIA schedule changes shall be included in the next Monthly Progress Schedule submission.
- k) Request for a contract time extension will not be processed until the receipt and approval of a Time Impact Analysis.

**G. Failure to Submit Progress Schedules and/or Recovery Schedules:**

- 1) No progress payment for this item of work shall be made until the progress schedule is “accepted” or “accepted as noted” by the Engineer.
- 2) If the Contractor’s Progress Schedule submission is rejected due to any deficiency noted in paragraph E.1(a) through (i), it shall be considered an incomplete submission and therefore substantially deficient.
- 3) If the Contractor’s revised Progress Schedule submission does not address the written comments provided by the Engineer, and does not include a written explanation with a reasonable rationale for not addressing those comments, the submission shall be considered deficient.

**H. Recovery Schedule**

- 1) If the latest completion time for any work on the current Progress Schedule results in an activity being delayed ten percent or more of the time beyond the required Contract duration or any specified Milestone duration, as adjusted if appropriate, the Engineer may require the Contractor to submit a Recovery Schedule and written description of the plan to recover all lost time and maintain the required Completion Date or specified Interim Milestone Date(s).
- 2) With the Recovery Schedule the Contractor shall submit a narrative that identifies where additional labor and/or equipment resources will be allocated. Alternately, the Contractor may elect to provide

**ITEM 639.10220001 – CPM (CRITICAL PATH METHOD) PROGRESS SCHEDULE - Type 2**

the makeup of their Crew resources in the narrative, and assign those Crew resources to the appropriate activities in the Progress Schedule. The makeup of the Crew shall include the various Labor classes and equipment that comprise the Crew along with the quantity of each labor class and type of equipment. Equipment resources shall be shown for major or specialty equipment such as tower cranes, piledrivers, barges, asphalt pavers, concrete pavers, dozers, front end loaders, backhoes, rollers, excavators, graders, long line striping truck or other equipment that cannot be rented easily. Either of these alternatives may be supplemented with a request for a Contract Time Extension. The Contractor shall provide a reasonable plan for accomplishing the work of the contract within the current completion date, or to the requested contract extension date. The Engineer will use the Recovery Schedule to evaluate time extensions, with or without charges.

**I. Additional requirements for progress schedules with projected Early Completion date(s):**

- 1) The Contractor may show a projected early completion date on any progress schedule submission provided that all of the requirements of the contract are met. The Contractor may increase early completion time by incorporating a longer work week (6 Day/8 Hr Workweek instead of 5 Day/8 Hr Workweek), adding additional shifts, increasing the number of crews, reallocating resources to be more efficient, or adopting aggressive scheduling and construction management processes.
- 2) If the Contractor submits a progress schedule that indicates an anticipated early completion date(s) that is/are less than 90% of the specified contract milestone duration, the Progress Schedule submission shall be supplemented with Labor and Equipment resources assigned to every task activity in the schedule. The Contractor shall use resource leveling when scheduling the project and include time-scaled resource histograms with the Progress Schedule submission. The resource allocations must be shown to a level of detail that facilitates report generation based on labor crafts and equipment classes for the Contractor and subcontractors work. The Contractor shall, as a minimum, use average composite crew resources to display the labor loading of on-site construction activities and these crew resources in the resource dictionary shall identify the individual labor crafts comprised within the crew under the Notes tab of the crew resource. The Contractor shall optimize and level labor to reflect a reasonable plan for accomplishing the work of the contract and to assure that resources are not duplicated in concurrent activities.

**J. Float**

During the course of contract execution, Total Float generated due to the efficiencies of either party (State or Contractor) will generally be considered Project Float that is not for the sole use of the party generating the float; rather it is a shared commodity to be reasonably used by either party. Any party assigned activity responsibility within the schedule has the full use of the Project Float until it is depleted.

However, if the Contractor submits a request for an Early Completion that includes a revised Progress Schedule supplemented with resource allocations for each task activity and time-scaled resource histograms that is accepted by the Department, then Total Float actually resulting from additional Contractor resources, additional work shifts, longer work weeks or adoption of more aggressive scheduling and construction management practices of the Contractor's work activities may be considered Contractor Owned Float for the exclusive use of the Contractor. Refer to paragraph I for resource loading requirements for Early Completion Dates.

The Department may accrue State Owned Float by generating Total Float through different means. This includes: change(s) to the contract that relaxes restrictions on the Contractor, removes contract work or reduces quantities of items of work; early completion of Utility company activities; and early completion of Shop Drawing or submittal reviews. State Owned Float is considered a resource for the exclusive use by the State. The Engineer documents State Owned Float by directing the Contractor to update the State Owned Float activity on the next Monthly Progress Schedule submission. The Engineer may use State owned Float

## ITEM 639.10220001 – CPM (CRITICAL PATH METHOD) PROGRESS SCHEDULE - Type 2

to mitigate past, present or future State delays by offsetting potential time extensions for contract change orders.

For either the State or Contractor to reserve Total Float as State Owned Float or Contractor Owned Float the party must document within the schedule submission narrative in advance of generating the Total Float the additional resources or measures that will taken to shorten the critical path, and then document within the schedule submission narrative that immediately followed when the Total Float was actually generated the change to State or Contractor owned float based on entry of Actual Start and Actual Finish dates and percentage of work completed, and this must be agreed to by both parties in the next project Progress Meeting. Without this timely documentation any Total Float generated will be considered project float.

**K. Progress Schedule Updates and Weekly Status Reports:**

- 1) The Contractor shall perform a Progress Schedule Update on a minimum of a weekly basis, and every fourth schedule update period shall be consistent with monthly contract payment period.
- 2) The Contractor shall generate a Weekly Status Report after performing the Progress Schedule Update and Scheduling the project with a Data Date of day the schedule was updated, and submit it to the Engineer within one (1) State Business Day of the Data Date for that update period. The Weekly Status Report shall be generated using the activity Layout named Weekly Status Report, with activities grouped by the WBS, and using the standard default filter named Longest Path. The Gantt Chart shall clearly indicate the project critical (longest) path. Graphical representations shall be shown at a suitable scale to be legible and readable.
- 3) During any time periods within the contract that special time-related contract provisions are in effect, including B-Clock periods or Incentive/Disincentive Periods, the Engineer may require more frequent Progress Schedule Updates and/or Progress Schedule Status Reports.

**METHOD OF MEASUREMENT:**

The quantity shall be measured for payment on a Lump Sum basis.

The minimum lump sum bid for this item shall be the unit price shown in the itemized proposal.

Failure of the Contractor to bid at least the minimum amount will result in the Department adjusting the Contractor's bid to include the minimum bid amount for this item.

**BASIS OF PAYMENT:**

The lump sum price bid for CPM Progress Schedules shall include all labor, material, equipment, and incidentals, required to complete the work.

Progress payments will be made as follows:

- A. A total of twenty-five (25) percent will be paid upon achieving all of the following:
  1. Attendance at the Preconstruction Schedule Meeting
  2. Acceptance of the Baseline Progress Schedule @ Award.
  3. Acceptance of the Final Baseline Progress Schedule @ Award.
  4. Acceptance of the List of Submittals.
- B. A total of forty five (45) percent will be paid for acceptance of Monthly Progress Schedule submissions, acceptance of any necessary Time Impact Analysis, and acceptance of any necessary Recovery Schedules.

Progress payments for this item will be calculated by multiplying the Daily Payment Amount by the calendar days in the estimate period, less any deductions for unsatisfactory CPM Progress Schedules, Time Impact Analysis, or Recovery Schedules. The Daily Payment amount will be calculated by taking 45 percent of the total item cost divided by the number of calendar days in the contract duration as designated in the proposal, without regard to any extension of time

ITEM 639.10220001 – CPM (CRITICAL PATH METHOD) PROGRESS SCHEDULE - Type 2

- C. A total of twenty five (25) percent will be paid for submittal of Weekly Status Reports, participation in progress meetings, and submittal of Look-Ahead Schedules.  
Progress payments for this item will be calculated by multiplying the Bi-weekly Payment amount by the number of Bi-weekly periods (1 or 2) in the estimate period, less any deductions for unsatisfactory Status Reports or Look-Ahead Schedules, or non attendance at progress meetings. The Bi-weekly Payment amount will be calculated by taking 25 percent of the total item cost divided by the number of bi-weekly periods in the contract duration as designated in the proposal, without regard to any extension of time
- D. A total of five (5) percent will be paid upon acceptance of the As-Built Progress Schedule.

Following notification by the Engineer that there are deficiencies in compliance with the specification requirements, as described in paragraph E.1, with the submittal of any Progress Schedule no payment will be made under CPM Progress Schedules for each calendar day during which those deficiencies continue to exist. The amount of such calendar day non-payment will be the Daily Payment Amount as calculated above multiplied by the number of days there are deficiencies in compliance with the specification requirements.

Non-refundable liquidated damages may be assessed for each subsequent calendar day or part thereof that a cited deficiency resulting in non-payment is not corrected or is permitted to recur. Non-refundable liquidated damages will be assessed at the rate equal to four times the Daily Payment Amount as calculated above.

In the event the contract completion date is extended, no additional payment will be made for CPM Progress Schedules for Non-compensable Delays. If the contract completion date is extended due to a Compensable Delay than payment for maintaining and submitting additional CPM Progress Schedules, Weekly Status Reports, and weekly Look-Ahead Schedules shall be equal to the Daily Payment Amount as calculated above multiplied by the number of calendar days the contract is extended plus the Bi-weekly Payment Amount multiplied by the number of bi-weekly periods the contract is extended.

*Payment will be made under:*

<b>Item No.</b>	<b>Item</b>	<b>Pay Unit</b>
639.10220001	CPM (Critical Path Method) Progress Schedule – Type 2	LS

**ITEM 685.0720XX18 - EPOXY REFLECTORIZED PAVEMENT MARKINGS – 20 MILS  
(WET NIGHT VISIBILITY SPHERES)**

**ITEM 685.0815XX18 - EPOXY REFLECTORIZED PAVEMENT MARKINGS - 15  
MILS (WET NIGHT VISIBILITY SPHERES)**

**DESCRIPTION**

Under this work the contractor shall furnish and apply epoxy reflectorized pavement markings in accordance with these specifications, the Contract Documents, the NYSMUTCD, or as ordered by the Engineer.

The epoxy marking material shall be hot-applied by spray methods onto bituminous and portland cement concrete pavement surfaces at the thickness and width shown on the Contract Documents. Following a simultaneous application of Type I and Type II glass beads, the cured epoxy marking shall be an adherent reflectorized stripe that will provide wet night reflectivity.

**MATERIALS REQUIREMENTS**

**A. Epoxy Material**

**1.0 Composition**

The epoxy resin composition shall be specifically formulated for use as a pavement marking material and for hot-spray application at elevated temperatures. The type and amounts of epoxy resins and curing agents shall be at the option of the manufacturer, providing the other composition and physical requirements of this specification are met.

The epoxy marking material shall be a two-component (Part A and Part B), 100% solids type system formulated and designed to provide a simple volumetric mixing ratio (e.g. two volumes of Part A to one volume of Part B).

The epoxy marking material shall be supplied as either a regular-dry or a slow-dry material. Regular-dry may be used for all marking patterns. Slow-dry material is intended for marking hatchlines, edgelines, and other marking patterns located out of the general path of traffic.

Part A of both white and yellow shall conform to the following requirements:

**PERCENT BY WEIGHT OF PART A**

**WHITE**

\*Pigment - 18 Minimum, Titanium Dioxide (ASTM D476, Type II)

Epoxy Resin - 75 to 82

**YELLOW**

\*Pigment - 23 Minimum, Medium Chrome Yellow (ASTM D211, Type III)

Epoxy Resin - 70 to 77

\*The entire pigment composition shall consist of either titanium dioxide or medium chrome yellow. No extender pigments are permitted. The white pigment, upon analysis, shall contain a minimum of 16.5% TiO<sub>2</sub> (100% purity). Yellow paints shall use organic yellow pigments, Color Index Pigment Yellow 65 (C.I. 11740) and or 74 (C.I. 11741).



**ITEM 685.0720XX18 - EPOXY REFLECTORIZED PAVEMENT MARKINGS – 20 MILS  
(WET NIGHT VISIBILITY SPHERES)**

**ITEM 685.0815XX18 - EPOXY REFLECTORIZED PAVEMENT MARKINGS - 15  
MILS (WET NIGHT VISIBILITY SPHERES)**

The epoxy content of the epoxy resin in Part A will be tested in accordance with ASTM D1652 and calculated as the weight per epoxy equivalent (WPE) for both white and yellow. The epoxy content will be determined on a pigment free basis. The epoxy content (WPE) shall meet a target value provided by the manufacturer and approved by the Director, Materials Bureau. A  $\pm 50$  tolerance will be applied to the target value to establish the acceptance range.

The amine value of Part B shall be tested in accordance with ASTM D2074\* to determine its total amine value. The total amine value shall meet a target value provided by the manufacturer and approved by the Director, Materials Bureau. A  $\pm 50$  tolerance will be applied to the target value to establish the acceptance range.

\*The manufacturer may specify an alternate test method for determining the amine value subject to the approval of the Director, Materials Bureau.

**2.0 Physical Properties of Mixed Components (Part A & Part B)**

Unless otherwise noted, all samples are to be prepared and tested at an ambient temperature of  $73 \pm 3^{\circ}\text{F}$

- a. Color.** The white epoxy composition, when applied at a wet film thickness of  $15 \pm 1$  mils and allowed to cure, shall be a reasonable visual match to Munsell Book Notation N9.5/0 (ASTM D1535).

The yellow epoxy composition, when applied at a wet film thickness of  $15 \pm 1$  mils and allowed to cure, shall be a reasonable visual match to Munsell Book Notation 10YR 8/14 (ASTM D1535).

- b. Directional Reflectance.** The white epoxy composition (without glass spheres) shall have a daylight directional reflectance of not less than 84% relative to a magnesium oxide standard when tested in accordance with ASTM E1347.

The yellow epoxy composition (without glass spheres) shall have a daylight directional reflectance of not less than 55% relative to a magnesium oxide standard when tested in accordance with ASTM E1347.

- c. Drying Time (Laboratory).** When tested in accordance with ASTM D711 as modified below, regular-dry epoxy marking material shall reach a no-pick-up time in 30 minutes or less. Under these same test conditions, slow-dry epoxy marking material shall reach a no-pick-up time in 60 minutes or less. A Bird Applicator or other suitable instrument shall be used to spread a uniform  $15 \pm 1$  mils thick wet film.

Type I reflective glass spheres shall be immediately dropped onto the epoxy

**ITEM 685.0720XX18 - EPOXY REFLECTORIZED PAVEMENT MARKINGS – 20 MILS  
(WET NIGHT VISIBILITY SPHERES)**

**ITEM 685.0815XX18 - EPOXY REFLECTORIZED PAVEMENT MARKINGS - 15  
MILS (WET NIGHT VISIBILITY SPHERES)**

composition, followed by application of Type II glass spheres. Each type shall be applied at the rate of 10 lbs/gal of epoxy (total 20 lbs/gal).

- d. Drying Time (Field).** When installed at 77°F at the specified wet film thickness and reflectorized with Type I and Type II glass spheres, regular-dry and slow-dry epoxy markings shall reach a no-track condition in approximately 30 minutes, and 60 minutes, respectively.

Dry to "no-tracking" shall be considered as the condition where no visual deposition of the epoxy marking to the pavement surface is observed when viewed from a distance of 50 ft, after a passenger car is passed over the line.

- e. Abrasion Resistance.** The wear index of the composition shall not exceed 82 when tested in accordance with ASTM C501 using a CS-17 wheel and under a load of 2 pounds for 1000 cycles. Samples shall be allowed to cure for not less than 72 hours nor more than 96 hours prior to testing.
- f. Hardness.** The epoxy composition when tested in accordance with ASTM D2240 shall have a Shore D hardness of between 75 and 100. Samples shall be allowed to cure for not less than 72 hours nor more than 96 hours prior to testing.
- g. Infrared Spectrophotometer Analysis (ASTM D2621).** Samples of both Part A and Part B shall be analyzed by infrared spectrography to verify that the materials submitted for use are of an identical formulation as originally accepted by the Materials Bureau for the Department's "Approved List" of materials. Significant deviations, as determined by comparison with acceptable formulations, shall not be allowed.

**B. Reflective Glass Spheres**

Type I and Type II reflective glass spheres for drop-on application shall conform to the following requirements.

The glass spheres shall be colorless, clean, transparent, free from milkiness or excessive air bubbles, and essentially clean from surface scarring or scratching. They shall be spherical in shape and at least 70% of the glass beads shall be true spheres. Type I spheres shall be tested for roundness according to the procedural directives of the Materials Bureau. Type II spheres shall be tested in accordance with ASTM D1155, Procedure A.

The refractive index of the spheres shall be a minimum of 1.50 as determined by the liquid immersion method at 77°F.

The silica content of the glass spheres shall not be less than 60%.

**ITEM 685.0720XX18 - EPOXY REFLECTORIZED PAVEMENT MARKINGS – 20 MILS (WET NIGHT VISIBILITY SPHERES)**

**ITEM 685.0815XX18 - EPOXY REFLECTORIZED PAVEMENT MARKINGS - 15 MILS (WET NIGHT VISIBILITY SPHERES)**

The glass spheres, Type I and II, shall be coated with a silane-type adherence coating designed to interact with and adhere to epoxy pavement markings.

The glass spheres shall have the following gradation when tested in accordance with ASTM D1214.

<u>TYPE I</u>		<u>TYPE II</u>	
<b>U.S. Standard</b>	<b>Total %</b>	<b>U.S. Standard</b>	<b>Total %</b>
<b>Sieve No.</b>	<b>Passing</b>	<b>Sieve No.</b>	<b>Passing</b>
Passing # 10	100	Passing # 20	100
Passing # 12	95-100	Passing # 30	80-95
Passing # 14	75-95	Passing # 50	9-42
Passing # 16	10-47	Passing # 80	0-10
Passing # 18	0-7		
Passing # 20	0-2		

**C. Packaging and Shipment**

Epoxy pavement marking materials shall be shipped to the job site in strong, substantial containers.

Individual containers shall be plainly marked with the following information:

1. Name of Product
2. Item Number
3. Lot Number
4. Batch Number
5. Test Number
6. Date of Manufacture
7. Date of Expiration of Acceptance (6 months from date of manufacture)
8. The Statement (as appropriate)
  - Part A - Contains Pigment & Epoxy Resin
  - Part B - Contains Catalyst
9. Quantity

**ITEM 685.0720XX18 - EPOXY REFLECTORIZED PAVEMENT MARKINGS – 20 MILS  
(WET NIGHT VISIBILITY SPHERES)**

**ITEM 685.0815XX18 - EPOXY REFLECTORIZED PAVEMENT MARKINGS - 15  
MILS (WET NIGHT VISIBILITY SPHERES)**

10. Mixing proportions, Application Temperature and Instructions
11. Safety Information
12. Manufacturer's Name and Address

Reflective glass spheres shall be shipped in moisture resistant bags. Each bag shall be marked with the name and address of the manufacturer, the type (I or II) of glass sphere, and net weight of the material.

**D. Basis of Acceptance**

Only epoxy pavement marking materials from manufacturers appearing on the Department's Approved List shall be considered for acceptance. Details for obtaining Approved List status are available from the Materials Bureau.

Epoxy pavement marking materials will be sampled and tested in accordance with the procedural directives of the Materials Bureau. Samples will be taken at the manufacturing location and considered for acceptance in stock lot quantities.

Department red and green metal security seals will be placed on containers of pavement marking materials that meet specifications. The colored metal security seals serve as the evidence of acceptance for epoxy material delivered to the job site.

All acceptances of uninstalled epoxy marking material shall expire six (6) months after the date of manufacture.

Type I and Type II reflective glass spheres shall be accepted on the basis of the manufacturer's brand name or product code appearing on the Department's Approved list. Details for obtaining approved list status are available from the Materials Bureau.

**EPOXY APPLICATING EQUIPMENT**

Mobile applying equipment for the placement of epoxy reflectorized pavement markings shall be approved by the Director (Materials Bureau) prior to the start of work.

In general, a mobile applicator shall be a truck mounted, self-contained pavement marking machine, specifically designed to apply epoxy resin materials and reflective glass spheres in continuous and skip-line patterns. The applying equipment shall be maneuverable to the extent that straight lines can be followed and normal curves can be made in a true arc. In addition, the truck mounted unit shall be provided with accessories to allow for the marking of legends, symbols, crosswalks, and other special patterns.

At any time throughout the duration of the project, the Contractor shall provide free access to his epoxy applying equipment for inspection by the Engineer or his authorized representative.

The Engineer may approve the use of a portable applicator in lieu of mobile truck mounted accessories for use in applying special markings only, provided such equipment can demonstrate satisfactory application of reflectorized epoxy markings in accordance with these specifications.

**ITEM 685.0720XX18 - EPOXY REFLECTORIZED PAVEMENT MARKINGS – 20 MILS  
(WET NIGHT VISIBILITY SPHERES)****ITEM 685.0815XX18 - EPOXY REFLECTORIZED PAVEMENT MARKINGS - 15  
MILS (WET NIGHT VISIBILITY SPHERES)**

Mobile applying equipment shall be capable of installing up to 98,400 ft of epoxy reflectorized pavement markings in an eight hour day and shall include the following features:

1. Individual tanks for the storage of Part A and Part B of the epoxy resin.
2. Individual tanks for the storage of Type I and Type II glass spheres. Each tank shall have a minimum capacity of 3000 lbs.
3. Heating equipment of sufficient capacity to maintain the individual epoxy resin components at the manufacturer's recommended temperature for spray application.
4. Individual dispensers for the simultaneous application of Type I and Type II glass spheres. Each dispenser shall be capable of applying spheres at a minimum rate of 10 lbs/gal of epoxy resin composition.
5. Metering devices or pressure gauges on the proportioning pumps, positioned to be readily visible to the Engineer.
6. All necessary spray equipment, mixers, compressors, and other appurtenances for the placement of epoxy reflectorized pavement markings in a simultaneous sequence of operations as described in Construction Details, D. Application of Epoxy Reflectorized Pavement Markings.

**CONSTRUCTION DETAILS****A. General**

All pavement markings and patterns shall be placed as shown on the Contract Documents and in accordance with the New York State, Manual of Uniform Traffic Control Devices (MUTCD).

Before any pavement marking work is begun, a schedule of operations shall be submitted for the approval of the Engineer.

At least five (5) days prior to starting striping, the Contractor shall provide the Engineer with the epoxy manufacturer's written instructions for use. These instructions shall include, but not be limited to, material mixing ratios and application temperatures.

When pavement markings are applied under traffic, the Contractor shall provide all necessary flags, markers, signs, etc. in accordance with the MUTCD to maintain and protect traffic, and to protect marking operations and the markings until thoroughly set.

The application of pavement markings shall be done in the general direction of traffic. Striping against the direction of traffic flow shall not be allowed.

The Contractor shall be responsible for removing, to the satisfaction of the Engineer, all tracking marks,

**ITEM 685.0720XX18 - EPOXY REFLECTORIZED PAVEMENT MARKINGS – 20 MILS  
(WET NIGHT VISIBILITY SPHERES)**

**ITEM 685.0815XX18 - EPOXY REFLECTORIZED PAVEMENT MARKINGS - 15  
MILS (WET NIGHT VISIBILITY SPHERES)**

spilled epoxy, and epoxy markings applied in unauthorized areas.

When necessary the Contractor shall establish marking line points at **thirty (30) ft** intervals throughout the length of the pavement or as directed by the Engineer.

**B. Atmospheric Conditions**

Epoxy pavement markings shall only be applied during conditions of dry weather and on substantially dry pavement surfaces. At the time of installation the pavement surface temperature shall be a minimum of 50°F and the ambient temperature shall be a minimum of 50°F and rising. The Engineer shall be the sole determiner as to when atmospheric conditions and pavement surface conditions are such to produce satisfactory results.

**C. Surface Preparation**

The Contractor shall clean the pavement and existing durable markings to the satisfaction of the Engineer.

Surface cleaning and preparation work shall be performed only in the area of the epoxy markings application.

At the time of application all pavement surfaces and existing durable markings shall be free of oil, dirt, dust, grease and similar foreign materials. The cost of cleaning these contaminants shall be included in the bid price of this item.

In addition, concrete curing compounds on new portland cement concrete surfaces and existing painted pavement markings on both concrete and bituminous pavement surfaces shall be cleaned and paid for in accordance with Section 635, Cleaning and Preparation of Pavement Surfaces for Pavement Markings.

**D. Application of Epoxy ReflectORIZED Pavement Markings**

Epoxy reflectORIZED pavement markings shall be placed at the width, thickness, and pattern designated in the Contract Documents.

Marking operations shall not begin until applicable surface preparation work is completed and approved by the Engineer, and the atmospheric conditions are acceptable to the Engineer.

Pavement markings shall be applied by the following simultaneous operation:

1. The pavement surface is air-blasted to remove dirt and residues.
2. The epoxy resin, mixed and heated in accordance with the manufacturer's recommendations, is uniformly hot-sprayed onto the pavement surface at the minimum specified thickness.

**ITEM 685.0720XX18 - EPOXY REFLECTORIZED PAVEMENT MARKINGS – 20 MILS  
(WET NIGHT VISIBILITY SPHERES)**

**ITEM 685.0815XX18 - EPOXY REFLECTORIZED PAVEMENT MARKINGS - 15  
MILS (WET NIGHT VISIBILITY SPHERES)**

3. Type I and Type II reflective glass spheres are injected into or dropped onto the liquid epoxy marking. Type I beads shall be applied first immediately followed by the application of Type II beads. Each type shall be applied at a minimum rate of 10 lbs/gal of epoxy resin (minimum total application = 20 lbs/gal).

**E. Defective Epoxy Pavement Markings**

Epoxy reflectORIZED pavement markings, which after application and curing are determined by the Engineer to be defective and not in conformance with this specification, shall be repaired. Repair of defective markings shall be the responsibility of the Contractor and shall be performed to the satisfaction of the Engineer as follows:

1. Insufficient film thickness and line width; insufficient glass bead coverage or inadequate glass bead retention.

Repair Method. Prepare the surface of the defective epoxy marking by grinding or blast cleaning. No other cleaning methods will be allowed. Surface preparation shall be performed to the extent that a substantial amount of the reflective glass spheres are removed and a roughened epoxy marking surface remains.

Immediately after surface preparation remove loose particles and foreign debris by brooming or blasting with compressed air.

Repair shall be made by restriping over the cleaned surface in accordance with the requirements of this specification and at the full thickness indicated on the Contract Documents.

2. Uncured or discolored epoxy\*; insufficient bond (to pavement surface or existing durable marking).

Repair Method. The defective epoxy marking shall be completely removed and cleaned to the underlying pavement surface in accordance with the requirements of Section 635 - Cleaning and Preparation of Pavement Surfaces, at the Contractor's expense.

The extent of removal shall be the defective area plus any adjacent epoxy pavement marking material extending one meter in any direction.

After surface preparation work is complete, repair shall be made by reapplying epoxy over the cleaned pavement surface in accordance with the requirements of this specification.

\*Uncured epoxy shall be defined as applied material that fails to cure (dry) in accordance with the requirements of this specification: MATERIALS, A., 2.0 paragraph d. Drying Time (Field); or applied material that fails to cure (dry) within a reasonable time period under actual field conditions, as

**ITEM 685.0720XX18 - EPOXY REFLECTORIZED PAVEMENT MARKINGS – 20 MILS  
(WET NIGHT VISIBILITY SPHERES)**

**ITEM 685.0815XX18 - EPOXY REFLECTORIZED PAVEMENT MARKINGS - 15  
MILS (WET NIGHT VISIBILITY SPHERES)**

defined by the Engineer.

Discoloration shall be defined as localized areas or patches of brown, grayish or black colored epoxy marking material. These areas often occur in a cyclic pattern and often are not visible until several days or weeks after markings are applied.

Other defects not noted above, but determined by the Engineer to need repair, shall be repaired or replaced as directed by and to the satisfaction of the Engineer.

All work in conjunction with the repair or replacement of defective epoxy reflectorized pavement markings shall be performed by the Contractor at no additional cost to the State.

**METHOD OF MEASUREMENT**

Pavement striping will be measured in meters along the centerline of the pavement stripe and will be based on a 4-in wide stripe. Measurement for striping with a width greater than the basic 4 inches, as shown on the plans or directed by the Engineer, will be made by the following method:

$$\frac{\text{Plan Width of Striping (inches) X Feet}}{4 \text{ inches}}$$

Letters and symbols will be measured by each unit applied. A unit will consist of one letter or one symbol. Example: "SCHOOL" would be paid as six units.

**BASIS OF PAYMENT**

The accepted quantities of markings will be paid for at the contract unit price, which shall include the cost of furnishing all labor, materials and equipment to satisfactorily complete the work. The cost for maintaining and protecting traffic during the marking operations shall be included in the price bid. The cost of removal of concrete curing compounds and existing pavement markings will be paid under separate items and are not included in this item.

No payment will be made for the repair or replacement of defective epoxy reflectorized pavement markings.

No payment will be made for the number of linear meters of skips in the dashed line.

Baqd00

<u>PAY ITEM NO.</u>	<u>ITEM</u>	<u>PAY UNIT</u>
685.07200118	White Epoxy ReflectORIZED Pavement Stripes – 20 mils (Wet Night Visibility Spheres)	Foot



**ITEM 685.0720XX18 - EPOXY REFLECTORIZED PAVEMENT MARKINGS – 20 MILS  
(WET NIGHT VISIBILITY SPHERES)**

**ITEM 685.0815XX18 - EPOXY REFLECTORIZED PAVEMENT MARKINGS - 15  
MILS (WET NIGHT VISIBILITY SPHERES)**

685.07200218	Yellow Epoxy ReflectORIZED Pavement Stripes – 20 mils (Wet Night Visibility Spheres)	Foot
685.07200318	White Epoxy ReflectORIZED Pavement Letters – 20 mils (Wet Night Visibility Spheres)	Each
685.07200418	White Epoxy ReflectORIZED Pavement Symbols – 20 mils (Wet Night Visibility Spheres)	Each
685.08150118	White Epoxy ReflectORIZED Pavement Stripes – 15 mils (Wet Night Visibility Spheres)	Foot
685.08150218	Yellow Epoxy ReflectORIZED Pavement Stripes – 15 mils (Wet Night Visibility Spheres)	Foot
685.08150318	White Epoxy ReflectORIZED Pavement Letters - 15 mils (Wet Night Visibility Spheres)	Each
685.08150418	White Epoxy ReflectORIZED Pavement Symbols – 15 mils (Wet Night Visibility Spheres)	Each

**ITEM 691.03000020 – TRAINING REQUIREMENTS****DESCRIPTION**

This item of work shall consist of the meaningful and effective training of one or more apprentices/trainees leading to their qualification as journeyworkers in trades for the highway construction industry. The statutory authority for training requirements is described in §102-11 *Equal Employment Opportunity Requirements*. This specification establishes the specific requirements for a Contractor to provide training pursuant to 23 CFR 230.111 as part of Equal Employment Opportunity responsibilities. This specification, with referenced Standard Specifications, constitutes “Training Special Provisions” (TSP) pursuant to 23 CFR 230.111. The TSP supercedes any conflicting portions of Form FHWA 1273 *Required Contract Provisions, Federal Aid Construction Contracts* found in contract proposals.

**MATERIALS**

None Specified.

**CONSTRUCTION DETAILS**

**GENERAL.** The objective of these training requirements is to provide training opportunities to minorities, women and disadvantaged persons for the following reasons:

1. To address the current under-representation of minorities and women in skilled trades, and;
2. To maintain a pool of qualified minorities, women and disadvantaged persons to compete for those journeyworker positions which are created as others leave the workforce.

Disadvantaged means a person who is either a) a member of a family that receives public assistance, or b) a member of a family whose income during the previous six (6) months, on an annualized basis, was such that the family qualified for public assistance, or whose income was at or below either the poverty level or 70% of the lower living standard income (LLSI) level for the person’s county of residence.

The Contractor shall make every effort to recruit and hire minority, women and disadvantaged apprentices/trainees to the extent that such persons are available within a reasonable area of recruitment. Such training commitment is not intended to, and shall not be used to, discriminate against any applicant for training, whether a member of a minority group or not. Apprentices/trainees shall be employed and offered meaningful and effective training opportunities. Meaningful and effective training is defined as occurring when contract work provides a realistic and practical opportunity of reasonable duration for the apprentice/trainee to complete elements of the apprenticeship/OJT program in order to achieve journeyworker status.

**TRAINING PROGRAMS.** In accordance with §102-10D *Training*, an apprentice is defined as an individual who is enrolled in an apprenticeship training program that is registered with the NYS Department of Labor, and a trainee is defined as an individual who is enrolled in an On-the-Job Training (OJT) program that is approved by the Federal Highway Administration (FHWA). NYSDOT administers the trainee training programs.

Although the terms apprentices and trainees are generally used interchangeably in this specification, in Regions 1, 2, 3, 4, 5, 8, 10 and 11, the Department will only approve the use of apprentices and apprenticeship training programs, where available, in fulfillment of these requirements. In Regions 6, 7 and 9, the Department will approve the use of either apprenticeship or FHWA approved OJT trainee programs.

Prospective bidders can obtain additional information about apprentice programs from the Director of Apprenticeship Training Programs, NYS Department of Labor, State Office Building Campus, Building 12, Rm 436, Albany, NY 12240 ; (518) 457-6820; fax (518) 457-7154; [atco@labor.state.ny.us](mailto:atco@labor.state.ny.us).

**ITEM 691.03000020 – TRAINING REQUIREMENTS**

Approval to use a training program shall be obtained from the Department prior to commencing work involving the trade(s) covered by the program.

**APPRENTICES/TRAINEES.**

Recruitment. The Contractor shall decide who is hired as an apprentice/trainee. Such apprentice/trainee shall be enrolled in a registered apprenticeship or OJT program approved by the Department and satisfy the requirements under *Work History*.

Prior to engaging in the recruitment of new apprentice/trainees, the Contractor shall employ apprentices/trainees who are partially trained, if available, in order to facilitate completion of their apprenticeship/OJT program. Training and upgrading of minorities and women toward journeyworker status is a primary objective of the TSP requirements.

The Contractor shall make every effort to enroll minority and women apprentice/trainees (e.g., by conducting systematic and direct recruitment through public and private sources likely to yield minority and women apprentice/trainees, such as the Department’s OJT supportive services program) to the extent that such persons are available within a reasonable area of recruitment. The Contractor will be responsible for demonstrating the steps that have been taken in pursuance thereof, prior to a determination as to whether the Contractor is in compliance with the TSP requirements.

Work History. The Contractor shall not propose or use any person under this item if such person has successfully completed a training program providing journeyworker status in the same trade or work classification as will be used for training under this contract. The Contractor shall not use or propose a person who has been gainfully employed as a journeyworker in that trade by virtue of informal on-the-job training or otherwise. The Contractor shall ascertain, before training a person and before requesting payment therefore, whether the person qualifies. The Contractor shall include appropriate questions on employee application forms and shall check the personal references of an applicant for a position in order to ensure that the person is qualified for training. The Contractor shall maintain records of these findings and provide them to the Department upon request.

Termination. An apprentice/trainee may be terminated at any time during training for: excessive absenteeism; lack of punctuality; accident-proneness; lack of interest; poor attitude; and continued failure to behave in a business-like manner. However, termination will not occur without:

1. Documented counseling by the Contractor's Trainer about the reason(s) for termination; and
2. Documented efforts by the Contractor's Trainer to resolve the problem; and
3. Documented notification to the Engineer and Regional Compliance Specialist about the problem; and
4. Written notification of intent to terminate to the Engineer and the Regional Compliance Specialist stating the reason(s) therefore; and
5. An opportunity for Department representatives to discuss the impending termination with the Contractor in order to ensure compliance with Steps 1 through 4 above.

**REQUIRED TRAINING EFFORT.**

<b>CHART A</b>			
<b>NUMBER OF APPRENTICE/TRAINEE FTEs REQUIRED</b>			
<b>Contract Bid Amount</b>	<b>AA Component</b>	<b>RGN Component</b>	<b>Total (AA + RGN)</b>
< \$15M	1	1	2
\$15M to < \$30M	2	2	4
≥ \$30M	3	3	6

**ITEM 691.0300020 – TRAINING REQUIREMENTS**

**Full-Time Equivalents (FTEs).** The number of apprentice/trainee full-time equivalents (FTEs) the Contractor is required to train is identified in Chart A. For the purposes of this specification, FTEs are used to designate the desired and expected level of training effort, in terms of full-time workers employed for the duration of the contract. Although the value of one FTE is not fixed, a general estimation of expected effort is approximately 1,000+ hours of work per construction season for upstate Regions and 2,000+ hours of work per construction season for downstate Regions. One FTE could be achieved with one individual working for the contract duration or with multiple individuals working full-time on a daily basis for portions of the contract duration so long as they are collectively employed for the equivalent amount of time as one full-time employee working for the entire duration of the contract. Accordingly, the Contractor may propose a different number of trainees/apprentices and a different duration of their training activities to achieve the required number of FTEs, but the proposal is subject to the approval of the Department.

**Affirmative Action (AA) Component.** The affirmative action (AA) component identifies locations and trades with programmatic under-representation of minorities and/or females as journeyworkers. The Contractor shall provide the appropriate number of apprentices/trainees FTEs to fulfill the affirmative action (AA) requirements of this specification in the specified trade(s) and classification(s) (minority or female). The number of AA apprentice/trainee FTEs required are identified in *Chart A* and the required trade/classification targets for each NYSDOT Region are identified in *Chart B*.

<b>CHART B AFFIRMATIVE ACTION TARGETS</b>											
<b>TRADE</b>	<b>NYSDOT REGION</b>										
<b>1</b>	<b>1</b>	<b>2</b>	<b>3</b>	<b>4</b>	<b>5</b>	<b>6</b>	<b>7</b>	<b>8</b>	<b>9</b>	<b>10</b>	<b>11</b>
Laborer (Female)										•	
Laborer (Minority)				•							•
Equip. Operator (Female)	•	•	•	•		•		•	•		
Equip. Operator (Minority)		•	•	•	•			•		•	•
Iron Worker (Female)	•				•			•		•	•
Iron Worker (Minority)			•					•		•	•
Carpenter (Female)	•		•				•				•
Carpenter (Minority)	•		•	•				•		•	•
Mason (Female)	•				•						
Mason (Minority)					•						
Painter (Female)			•						•	•	•
Painter (Minority)											•
Electrician (Female)									•		
Electrician (Minority)			•	•				•			•

**Race/Gender Neutral (RGN) Component.** The Contractor shall also provide the appropriate number of apprentices/trainees FTEs to fulfill the race/gender neutral (RGN) requirements in accordance with *Chart A*. The RGN component allows the Contractor to hire apprentices without imposed race, gender or specific trade requirements. Training shall be provided to anyone (minorities/non-minorities, males/females, and disadvantaged/non-disadvantaged persons) at the Contractor's discretion.

**ITEM 691.03000020 – TRAINING REQUIREMENTS**

Although trades are not designated for the RGN apprentices/trainees, training should be provided in the construction trades rather than in clerical/administrative positions. Training is permissible, by Department authorized exception only, in lower level management positions such as office engineers, estimators, timekeepers, etc., where the training is oriented toward construction applications. On a voluntary basis, the Contractor has the option to help address areas with programmatic under-representations, by hiring the RGN apprentices/trainees to the designated areas outlined in *Chart B – Affirmative Action Targets*.

**Implementation and Distribution.** The number of apprentices/trainees FTEs shall be distributed among the trades based upon the AA component requirements, maximum opportunity for work, required journeyworker/apprentice ratios outlined in the prevailing wage rate schedule, distribution of multiple persons among multiple trades, the Contractor's needs and the availability of apprentices/trainees within a reasonable area of recruitment.

When multiple apprentices/trainees are required, effort shall be made to hire apprentices/trainees whom are at a variety of different stages in their training programs (first year, third year, etc.) Where feasible, 25 percent of apprentices/trainees shall be in their first year of apprenticeship or training.

The Contractor may allow apprentices/trainees to be trained by a subcontractor. However, the Contractor retains the primary responsibility to meet the TSP requirements and compensation is the same.

**Compliance.** A Contractor will have fulfilled the primary responsibilities under this Training Special Provision if acceptable training is provided to the number of apprentice/trainee FTEs specified or good faith efforts to attempt to provide the required training is demonstrated consistently throughout the duration of the contract.

**Training Coordinator.** The Contractor shall designate one individual who will function as the training coordinator and act as the contact person for training related concerns. The training coordinator should be someone that has regular dealings and familiarity with the actual training direction and guidance being provided. As conditions and apprentices/trainees may change throughout the duration of the contract, notify the Department if at any point a new training coordinator is designated.

**TSP PROCESS.**

**Prior to Letting.** Bidders are advised that there are a number of procedural steps in the approval of a training (apprenticeship or OJT) program, including preparation of an application, review, and resolution of questions and comments. Approval of a training program is not guaranteed, and may take 30 to 60 days. It is highly recommended to have an approved apprenticeship or OJT trainee program prior to bidding.

**Within 7 Days After Letting.** As a requirement of the contract award process, the apparent low bidder shall submit a TSP Letter to the Department within 7 work days after letting, signed and dated by an authorized company officer. A recommended form, which includes the mailing address, for the TSP Letter is available from the Department's website at:

<https://www.nysdot.gov/main/business-center/contractors/construction-division/forms-manuals-computer-applications-general-information/civil-rights>

The minimum content requirements for the TSP Letter include:

- A statement acknowledging the TSP requirements and a pledge to make every effort to meet them
- Recognition of the number of apprentices required under the AA component, under the RGN component, and the total
- Recognition of the Region-specific affirmative action apprentice/trainee targets by trade and

**ITEM 691.03000020 – TRAINING REQUIREMENTS**

candidate classification (ex., female equipment operators, minority electricians, etc.)

- Identification of how the TSP requirements will be met (ex., union-sponsored apprentice program, contractor-sponsored apprentice program or OJT program)
- Status of program/application (if pending, attach a copy of the letter from NYSDOL verifying receipt of the application, for Department verification and consultation with NYSDOL.)
- Contact information: contact person, telephone number, E-mail address and mailing address.

At the Pre-Construction Meeting. The Contractor shall submit a conceptual plan for how they will fulfill the training requirements on the contract. They shall identify anticipated contract work suitable for apprentices/trainees, any timeline/scheduling issues, anticipated sources for apprentices/trainees, steps taken to date to comply with the training requirements, and how they will address the development of a training plan for each apprentice/trainee.

Within 90 Days of Award. The Contractor shall submit a formalized training plan for each of the apprentices/trainees. All coordination with the Engineer and the Regional Compliance Specialist (RCS) regarding the training plan should be completed at this point. The training plan may be adjusted throughout the duration of the contract as necessary. Written requests to submit the plan, or portions of the plan, at a specified latter date will be considered depending on the reason for the request. The cost estimate shall be submitted within 90 calendar days of the contract award date regardless of whether or not the training plan is allowed to be submitted at a latter date.

The minimum content requirements for the training plan(s) include:

- Name of the apprentice/trainee, trade, starting level (i.e., year of apprenticeship) and which TSP requirement (AA or RGN) the candidate is fulfilling.
- Apprentice/trainee projected start date, projected end date and the reason for ending the training (e.g., training program completed, no remaining training opportunities, contract completion, etc.).
- An outline of the training program requirements the candidate has already completed and the requirements which the candidate still has left to complete. Provide the associated number of hours for each requirement. List classroom and on-site training requirements separately.
- Total number of on-site (non-classroom) hours left to complete the training program.
- Projection of the hours and components of the remaining training program requirements which the candidate will be able to accomplish on the contract.
- A cost estimate for compensation which shows how the amount was calculated.
- Any known outside factors that might affect the training plan, such as if the apprentice/trainee will be working on other contracts or there may be time constraints of the apprentice (ex., planned future reassignment, leave to attending school, moving/relocating, etc.).
- Copies of the NYSDOL Form AT 14 (blue book), or acceptable equivalent, for each apprentice shall be made available.
- A copy of NYSDOL form AT 401 – *Apprenticeship Agreement/Documentation Form*.

Monthly Training Progress Report. The Contractor shall submit Form AAP 26 - *Monthly Training Progress Report* whenever an apprentice/trainee employed pursuant to this item begins work on a contract and monthly thereafter. In addition to each Monthly Training Progress Report, the Contractor shall provide the Engineer a summary of hours required to complete the various work elements of the training program, hours completed this period, and hours completed to date. This summary shall be provided in sufficient detail to allow the Engineer to determine whether the hours in the previous period are qualified hours under this pay item.

**ITEM 691.0300020 – TRAINING REQUIREMENTS**

*Periodic Auditing / End of Service.* Periodically copies of the training program and the NYSDOL Form AT 14 (blue book) may be required for auditing purposes and verification of the training. Whenever an apprentice/trainee ceases to be employed on a contract, a copy of their NYSDOL Form AT 14 (blue book) shall be provided.

**WAIVER REQUEST.** A request for a waiver of all or a portion of the TSP requirements may be submitted based on unusual circumstances which make the TSP requirements impractical or unduly burdensome to complete. The TSP requirements may be reduced or completely waived if the Contractor can clearly present a case for the TSP waiver (ex., no reasonable training opportunities will exist, lack of available apprentices/trainees, lack of available work for apprentices/trainees based on apprentice-to-journeyworker ratio restrictions). A TSP waiver request may be submitted at any point in the process after the contract letting date.

TSP waiver requests made within 7 work days after contract letting may be submitted in lieu of the TSP Letter. The TSP waiver request should provide a detailed explanation for the request, steps taken to try to comply, and contact person information (name, telephone number, E-mail address).

If the TSP waiver request is for elimination of all apprentice/trainee requirements and the TSP waiver is approved, no further TSP submissions are required. If the TSP waiver request is for a reduction or an alteration to the requirements and it is approved the Contractor shall submit a TSP Letter with the authorized revisions within 3 work days of notification of the TSP waiver request being approved.

In the event that a TSP waiver request is not approved, the Contractor shall submit a TSP Letter within 3 work days of notification of the TSP waiver request being declined.

The pre-award review of the TSP waiver request will focus on the apparent low bidder's good faith efforts to comply with these requirements, and will not eliminate the detailed review process of the contractor's workforce planning efforts and TSP compliance efforts after contract award.

TSP waivers are not necessarily permanent, particularly if based on available workforce reasons. Throughout the contract duration, the Contractor shall continue to try to meet the original requirements under this pay item. Whenever there are changes in the construction schedule, scope of work, availability of apprentices/trainees, or any other factor that might affect the ability to hire apprentices/trainees to reasonable training opportunities, any TSP waivers shall be reevaluated. The Contractor is required to bring any such factors to the attention of the Department in a timely manner.

**TRAINING DURATION.**

*Start-Up.* An apprentice/trainee shall begin training as soon as feasible in trade related work and remain on the contract as long as training opportunities exist in the trade, until completion of the training program or until completion of the contract.

After approval of an apprentice/trainee, the individual shall be employed in the designated trade in accordance with the currently approved Form AAP 35 *Workforce Participation Plan* to the extent that training opportunities exist in the contract work. At the time an apprentice/trainee reports to the Contractor for training under this item, the Training Coordinator shall notify the Engineer to ensure that appropriate records are kept.

**ITEM 691.0300020 – TRAINING REQUIREMENTS**

Throughout Contract Duration. The Contractor is expected to provide maximum opportunity to the apprentice/trainee for completion of their apprenticeship/OJT program. The Contractor shall monitor the apprentice/trainee's progress, paying particular attention to completion of work elements within the training program. When a work element of the training program is completed, the Contractor shall rotate the apprentice/trainee to other work processes to the extent that training opportunities exist. Should no such training opportunities exist, the apprentice/trainee may continue to work as long as there is work. However any work not in the training program or beyond the number of hours indicated in the training program for each work element will not qualify for payment under this pay item. This continued work will not make the apprentice/trainee ineligible for continued future training in the trade.

Retention. The Contractor is expected to retain, as a journeyworker, an apprentice/trainee that completes their training program and attains journeyworker status prior to contract completion, provided there is contract work remaining. Continued work by a journeyworker will not qualify for payment under this item.

Maintaining Compliance with the FTE Requirement. The Contractor is responsible for maintaining compliance with the required number of apprentice/trainee FTEs for the duration of the contract. If the number of employed TSP apprentice/trainee FTEs falls below the required number (e.g., apprentice/trainee attains journeyworker status, leave the contract, etc.) and there are substantial training opportunities remaining, the Contractor is required to make every effort to recruit and hire additional apprentices/trainees. Although, consideration to waive the remaining training requirements will be given when there is limited contract work remaining or when, due to the retention of TSP apprentices/trainees who have reached journeyworker status, available employment opportunities are limited.

If at any point during the contract the amount of training being accomplished is significantly below the projected amount stated in the training plan(s), the Contractor is required to adjust their training efforts such that the approved number of hours of training in the training plan(s) is achieved by contract completion.

**COMPENSATION.** This specification provides for partial compensation to the contractor towards the cost of managing and operating the training program(s). Compensation is not intended as reimbursement towards the apprentices' wages, but rather as general compensation for administrating the training program along with the loss of productivity on the behalf of the journeyworker(s) providing the training, guidance and supervision.

A combined negotiated amount for partial compensation of all the TSP apprenticeship/OJT programs will be added to the contract by order-on-contract. During the contract duration, revisions to the training plan(s) can be submitted. If a revised training plan, including the cost estimate, is approved then the previously negotiated amount can be adjusted by order-on-contract.

The Contractor shall attach to each Form AAP 26 *Monthly Training Progress Report*, a monthly summary of hours of qualifying training for each apprentice/trainee that shows the number of hours trained each day of the progress period by training program work element.

Only training hours verified and approved of by the Engineer or his designee will be considered as qualifying training. Any hours of work performed which are not in the training program or are beyond the number of hours indicated for each work element in the training program will not qualify for payment under this pay item. Off-site training or training performed at other work sites does not qualify for compensation. Classroom training hours do not qualify for compensation.



**ITEM 691.0300020 – TRAINING REQUIREMENTS**

The total verified hours of training provided during the month will be used to determine the monthly payment due. Regardless of the amount approved for the pay item, payments will be made only for the number qualifying hours of training accomplished.

Payment for training under the affirmative action component of this specification is contingent upon the Contractor fulfilling or demonstrating satisfactory good faith efforts to fulfill the corresponding equal employment opportunity (EEO) goals in accordance with §102-11 *Equal Employment Opportunity Requirements*. [*Example Situation #1* - For contracts with a minority EEO goal and a female EEO goal: If achieve the minority EEO goal but not the female EEO goal, then compensation may still be allowed for a minority TSP AA apprentice/trainee but not for a female TSP AA apprentice/trainee. *Example Situation #2*

- For contracts with trade specific minority/female EEO goals (i.e., applicable in New York City): If achieve the minority equipment operator EEO goal but not the minority iron worker EEO goal, then compensation may still be allowed for a minority equipment operator TSP AA apprentice/trainee but not for a minority iron worker TSP AA apprentice/trainee.]

Any apprentices/trainees hired towards attempting to attain fulfillment of the EEO goals do not qualify for payment under this specification nor are they considered as TSP apprentices/trainees (i.e., still required to hire additional apprentices/trainees under this specification's requirements).

Payment for training under the race/gender neutral component of this specification is contingent upon the Contractor fulfilling or demonstrating satisfactory good faith efforts to fulfill all of the equal employment opportunity (EEO) goals in accordance with §102-11 *Equal Employment Opportunity Requirements* and fulfilling or demonstrating satisfactory good faith efforts to fulfill the affirmative action component.

**METHOD OF MEASUREMENT**

This work will be measured on a Dollars-Cents basis. The amount shown in the proposal is not to be altered in any manner by the bidder. Should the bidder alter the amount shown, the altered figure will be disregarded, and the original price will be used to determine the total amount bid.

**BASIS OF PAYMENT**

Compensation towards the training program for each apprentice/trainee will be made as such:

$$= (0.35) \times (\text{Base Journeyworker Prevailing Wage Rate}) \times (\text{Hours of Qualifying Training Accomplished})$$

No adjustments to the base rate shall be allowed, such as for: fringes/supplemental benefits, premium rates (overtime, holiday, etc.), worker's compensation insurance, FICA, state or federal unemployment insurance, commercial general liability (CGL) insurance, etc. When determining compensation, use the prevailing wage rate that was current at the time the training was provided.

Qualified training time will include only verified training properly completed and accounted for, including only those hours the apprentice/trainee is actually receiving on-site training in the work elements included in his/her approved apprenticeship/OJT program. Off-site or related classroom training will not be considered as qualifying training time under this item.

**ITEM 698.93940001 – INCENTIVE PAYMENTS/DISINCENTIVE  
ASSESSMENTS /HOURLY BASIS**

**DESCRIPTION.** There is no physical work to be accomplished under this item. This item will enable the Department to make incentive payments to (or disincentive assessments against) the Contractor for early substantial completion (or late completion) of work included in the special note titled “Incentive/Disincentive Clause / Hourly Basis” based on the time or times specified in that special note.

**MATERIALS.** Not applicable.

**CONSTRUCTION DETAILS.** There are no construction details for this item.

**METHOD OF MEASUREMENT.** The method of measurement shall be lump sum. Actual payments-incentive (or deductions-disincentive) made under this item shall be as stated below.

**BASIS OF PAYMENT.** The amount set forth in the proposal is a fixed price for all bidders. Any bid, other than the specified amount shown in the itemized proposal, will be adjusted by the Department to the fixed price.

The Contractor shall be entitled to payment for this item as follows: To determine the actual lump sum payment-incentive or lump sum deduction-disincentive under this pay item, the number of hours actually required to accomplish the work included in the Incentive/Disincentive Clause will be compared to the number of hours specified for the same work in that special note. Should the identified work take longer than the number of hours specified (as may be adjusted under the contract terms), the number of hours in excess thereof will be multiplied by the hourly cost, and that product (lump sum) will be disincentive. Should the hours required to substantially complete the identified work be fewer than the number specified (as may be adjusted under the contract terms), the difference will be multiplied by the hourly cost, and the product (lump sum) will be paid to the contractor as incentive.

Incentive payments shall be made for each individual I/D work period upon completion of the work included in the particular I/D period. Disincentive assessments shall be made separately for each I/D work period upon reaching the completion time established for each I/D work period.

Deductions-disincentive made under the terms of this item shall be in addition to any deductions made as Liquidated Damages (only applied to non-I/D work). Any payments made under this item shall be regarded by the parties to include the cost of all overhead, profit, labor, equipment, supplies, materials, scheduling and management necessary to accomplish the work within the actual number of hours taken. The work of the other items in the contract will be measured and paid for separately under their appropriate items of work.



Federal Wage Rates

General Decision Number: NY120025 08/03/2012 NY25

Superseded General Decision Number: NY20100026

State: New York

Construction Types: Building, Heavy and Highway

County: Putnam County in New York.

BUILDING CONSTRUCTION PROJECTS (does not include residential construction consisting of single family homes and apartments up to and including 4 stories). HEAVY AND HIGHWAY CONSTRUCTION PROJECTS

Modification Number	Publication Date
0	01/06/2012
1	01/20/2012
2	01/27/2012
3	04/06/2012
4	04/13/2012
5	04/27/2012
6	05/04/2012
7	06/22/2012
8	07/06/2012
9	07/20/2012
10	08/03/2012

ASBE0091-001 05/28/2012

	Rates	Fringes
HAZARDOUS MATERIAL HANDLER (Duties limited to preparation, wetting, stripping, removal, scraping, vacuuming, bagging and disposing of all insulation materials whether they contain asbestos or not from mechanical systems).....	\$ 25.55	9.95
Insulator/asbestos worker (Includes application of all insulating materials, protective coverings, coatings, and finishes to all types of mechanical systems).....	\$ 38.54	30.31

BOIL0005-001 01/01/2012

	Rates	Fringes
BOILERMAKER.....	\$ 47.98	32%+21.75+a

FOOTNOTE:

a. PAID HOLIDAYS: New Year's Day, Thanksgiving Day, Memorial Day, Independence Day, Labor Day and Good Friday, Friday after Thanksgiving, Christmas Eve Day and New Year's Eve

Federal Wage Rates

BRNY0001-002 06/01/2011

	Rates	Fringes
Pointer, cleaner and caulker.....	\$ 37.55	26.10

BRNY0004-001 01/01/2011

	Rates	Fringes
MARBLE MASON.....	\$ 51.53	25.60

BRNY0005-004 08/01/2011

	Rates	Fringes
Bricklayer, Cement Mason, Plasterer & Stonemason BUILDING CONSTRUCTION Bricklayers, Cement Masons, Plasterers, Stone Masons.....	\$ 38.30	25.70
HEAVY & HIGHWAY CONSTRUCTION Bricklayers, Cement Masons, Plasterers, Stone Masons.....	\$ 38.80	25.70

BRNY0007-001 01/01/2011

	Rates	Fringes
TERRAZZO FINISHER.....	\$ 42.86	28.55
TERRAZZO WORKER/SETTER.....	\$ 44.39	28.55

BRNY0020-001 01/01/2011

	Rates	Fringes
MARBLE FINISHER.....	\$ 42.20	24.93

BRNY0024-001 07/01/2012

	Rates	Fringes
BRICKLAYER MARBLE POLISHERS.....	\$ 38.03	20.90

BRNY0052-001 12/05/2011

	Rates	Fringes
Tile Layer.....	\$ 49.64	26.91

BRNY0088-001 12/05/2011

	Rates	Fringes
TILE FINISHER.....	\$ 39.28	23.91

## Federal Wage Rates

-----  
CARP0279-002 07/01/2011

	Rates	Fringes
Carpenters:		
Building.....	\$ 32.63	30.45
Heavy & Highway.....	\$ 32.63	30.45

-----  
CARP0740-001 07/01/2010

	Rates	Fringes
MILLWRIGHT.....	\$ 46.19	44.93

-----  
CARP1456-004 01/01/2011

	Rates	Fringes
Dock Builder & Piledrivermen		
DOCKBUILDERS.....	\$ 46.21	38.36

-----  
CARP1456-005 01/01/2011

	Rates	Fringes
Diver Tender.....	\$ 41.16	38.46
Diver.....	\$ 58.01	38.46

-----  
ELEC0363-003 04/01/2011

PUTNAM COUNTY

	Rates	Fringes
ELECTRICIAN.....	\$ 41.00	23.33

-----  
ELEC1249-002 05/04/2009

	Rates	Fringes
LINE CONSTRUCTION: Lineman		
LIGHTING AND TRAFFIC		
SIGNAL INCLUDING ANY AND		
ALL FIBER OPTIC CABLE		
NECESSARY FOR THE TRAFFIC		
SIGNAL SYSTEMS, AND		
TRAFFIC MONITORING		
SYSTEMS, ROAD WEATHER		
INFORMATION SYSTEMS		
Flagman.....	\$ 23.00	13.50+6.5%+a
Groundman Digging Machine		
Operator.....	\$ 34.51	13.50+6.5%+a
Groundman Truck Driver		
(Tractor Trailer Unit).....	\$ 32.59	13.50+6.5%+a
Groundman Truck Driver.....	\$ 30.67	13.50+6.5%+a
Lineman and Technician.....	\$ 38.34	13.50+6.5%+a
Mechanic.....	\$ 30.67	13.50+6.5%+a

PAID HOLIDAYS:

Federal Wage Rates

a. Memorial Day, New Year's Day, President's Day, Good Friday, Decoration Day, Independence Day, Labor Day, Thanksgiving Day, Christmas Day, and Election Day for the President of the United States and Election Day for the Governor of New York State, provided the employee works two days before or two days after the holiday.

ELEC1249-004 01/01/2012

	Rates	Fringes
Line Construction:		
Overhead and underground distribution and maintenance work and all overhead and underground transmission line work including any and all fiber optic ground wire, fiber optic shield wire or any other like product by any other name manufactured for the dual purpose of ground fault protection and fiber optic capabilities (where no other trades are or have been involved):		
Flagman.....	\$ 24.79	15.00+6.5%+a
Groundman digging machine operator.....	\$ 37.19	15.00+6.5%+a
Groundman truck driver (tractor trailer unit).....	\$ 35.12	15.00+6.5%+a
Groundman Truck driver.....	\$ 33.06	15.00+6.5%+a
Lineman and Technician.....	\$ 41.32	15.00+6.5%+a
Mechanic.....	\$ 33.06	15.00+6.5%+a
Overhead transmission line work (where other trades are or have been involved):		
Flagman.....	\$ 26.29	15.00+6.5%+a
Groundman digging machine operator.....	\$ 39.44	15.00+6.5%+a
Groundman truck driver (tractor trailer unit).....	\$ 37.25	15.00+6.5%+a
Groundman truck driver.....	\$ 35.06	15.00+6.5%+a
Lineman and Technician.....	\$ 43.82	15.00+6.5%+a
Mechanic.....	\$ 35.06	15.00+6.5%+a
Substation:		
Cable Splicer.....	\$ 45.45	15.00+6.5%+a
Flagman.....	\$ 24.79	15.00+6.5%+a
Ground man truck driver....	\$ 33.06	15.00+6.5%+a
Groundman digging machine operator.....	\$ 37.19	15.00+6.5%+a
Groundman truck driver (tractor trailer unit).....	\$ 35.12	15.00+6.5%+a
Lineman & Technician.....	\$ 41.32	15.00+6.5%+a
Mechanic.....	\$ 33.06	15.00+6.5%+a
Switching structures; railroad catenary		

Federal Wage Rates

installation and maintenance, third rail type underground fluid or gas filled transmission conduit and cable installations (including any and all fiber optic ground product by any other name manufactured for the dual purpose of ground fault protection and fiber optic capabilities), pipetype cable installation and maintenance jobs or projects, and maintenance bonding of rails; Pipetype cable installation

Cable Splicer.....	\$ 46.87	15.00+6.5%+a
Flagman.....	\$ 25.57	15.00+6.5%+a
Groundman Digging Machine Operator.....	\$ 38.35	15.00+6.5%+a
Groundman Truck Driver (tractor-trailer unit).....	\$ 36.22	15.00+6.5%+a
Groundman Truck Driver.....	\$ 34.09	15.00+6.5%+a
Lineman & Technician.....	\$ 42.61	15.00+6.5%+a
Mechanic.....	\$ 34.09	15.00+6.5%+a

TELEPHONE, CATV FIBEROPTICS CABLE AND EQUIPMENT

Cable splicer.....	\$ 27.99	4.43 + 3%
Groundman.....	\$ 12.48	4.43 + 3%
Installer Repairman-Teledata Lineman/Tecnician-Equipment Operator.....	\$ 26.57	4.43 + 3%
Tree Trimmer.....	\$ 21.64	7.36+3%

FOOTNOTE:

a. PAID HOLIDAYS: New Year's Day, Presidents' Day, Memorial Day, Good Friday, Independence Day, Labor Day, Thanksgiving Day, Christmas Day, and Election Day for the President of the United States and Election Day for the Governor of New York State, provided the employee works two days before or two days after the holiday.

b. New Years Day, Washington's Birthday, Good Friday, Decoration Day, Independence Day, Labor Day, Veteran's Day, Thanksgiving Day, Day after Thanksgiving Day and Christmas Day.

-----  
ELEV0138-001 01/01/2012

	Rates	Fringes
ELEVATOR MECHANIC.....	\$ 50.11	23.535+a+b

FOOTNOTE:



Federal Wage Rates

a. 8 PAID HOLIDAYS: New Year's Day, Memorial Day, Independence Day, Labor Day, Veteran's Day, Thanksgiving Day, Friday after Thanksgiving, and Christmas Day.

b. PAID VACATION: Employer contributes 8% of regular basic hourly rate as vacation pay for employees with more than 5 years of service, and 6% for employees with less than 5 years of service.

-----  
ENGI0137-003 03/07/2011

	Rates	Fringes
Power equipment operators:		
BUILDING CONSTRUCTION		
GROUP 1.....	\$ 52.22	24.70+a
GROUP 1-A.....	\$ 45.67	24.70+a
GROUP 1-B.....	\$ 42.06	24.70+a
GROUP 1-C.....	\$ 52.22	24.70+a
GROUP 2-A.....	\$ 44.05	24.70+a
GROUP 3-A.....	\$ 42.42	24.70+a
GROUP 3-B.....	\$ 40.36	24.70+a
GROUP 4-A.....	\$ 41.99	24.70+a
GROUP 4-B.....	\$ 35.44	24.70+a
GROUP 5-A.....	\$ 40.36	24.70+a
GROUP 5-B.....	\$ 38.24	24.70+a
GROUP 6-A-1.....	\$ 47.94	24.70+a
GROUP 6-A-2.....	\$ 40.93	24.70+a
GROUP 6-A-3.....	\$ 46.46	24.70+a
GROUP 6-A-4.....	\$ 52.97	24.70+a
GROUP 6-A-5.....	\$ 41.57	24.70+a
GROUP 6-A-6.....	\$ 44.83	24.70+a
GROUP 6-B-1.....	\$ 36.26	24.70+a
GROUP 6-B-2.....	\$ 38.03	24.70+a
GROUP 6-B-3.....	\$ 38.10	24.70+a
GROUP 6-B-4.....	\$ 41.71	24.70+a

FOOTNOTE:

a. PAID HOLIDAYS: New Years Day, Memorial Day, Independence Day, Labor Day, Thanksgiving Day, Christmas Day, Lincoln's Birthday, Wasington's Birthday, Good Friday, Columbus Day, November Election Day, Veteran's Day

POWER EQUIPMENT OPERATORS CLASSIFICATIONS:

GROUP 1: Cranes (All types), Boom Trucks, Cherry Pickers (All types), Clamshell Crane, Derrick (Stone-Steel), Dragline, Franki Pile Rig or similar, High Lift (Lull & similar) with crane attachment and winch used for hoisting or lifting, Hydraulic cranes, Pile Drivers (all types).

GROUP 1-A: Carrier-trailer horse, concrete-portable hoist, crane & hoist engineer-steel (concrete, material, super structure substructure), derrick (stone-steel), elevator & cage, hoist- single-double-or triple drum), hoist-portable mobile unit, hoist engineer -concrete (crane-derrick-mine hoist), hoist engineer material, overhead crane, power house plant, telephies (cable way), whirly, maintenance engineer, lull highlift or similar, hydraulic crane 25 ton and over, cherry picker 25 ton an over; backhoe: Oliver 88,

**Federal Wage Rates**

Fordson, Dynahoe, Dual purpose and similar machines, Barber Green Loader, Euclid loader or similar type machine, conway or similar mucking machines; dragline, gradall, shovel, backhoe etc. (crawler or truck); front end loaders, hydraulic boom, Jersey spreader, lift slab console (etc), Letouneau or Tornapull (scrapers over 20 yds struck), mucking machines, pavement breaker (air ram), paver (concrete), road boring machine, road mix machines, Ross carrier and similar machines, post hole digger, shovels (tunnels), side boom, spreader (asphalt), scoopmobile-tractor-shovel over 1 1/2 yds., trenching type demolition equipment, winch truck ("a" frame), hydraulic crane over 10 tons up to 25 ton, cherry picker over 10 tons up to 25 ton.

GROUP 1-B: Compressor (steel erection); pulse meter and push button buzz box; elevator, mechanic (out-side) all types, welder, scraper-20 yds struck and under, shop foreman, machine pulling sheep's foot roller, vibratory rollers (etc), roller 4 ton and over.

GROUP 1-C: All Tower Cranes, all climbing cranes and all cranes of 100 ton capacity or greater irrespective of manufacturer and regardless of how the same is rigged.

GROUP 2-A: Compactor self-propelled; grader; bulldozer D7 with a draw bar horsepower of 100 or over; bulldozer D6 and under, shop foreman, machine pulling sheep's foot roller, vibratory rollers (etc).

GROUP 3-A: Asphalt plant; boiler (high pressure); concrete mixing plants; concrete pump; firemen; forklift; forklift (electric); joy drill or similar tractor drilling machine; loader - 1 1/2 yards and under; locomotive (all sizes); mixer concrete - 21E and over; portable asphalt plant; portable batch plant; portable crusher; quarry master; stone crusher; well drilling machine and well point system; cherry picker under 10 tons; hydraulic crane under 10 tons, concrete buggy one yard and up ride on dumpster, Benford or similar.

GROUP 3-B: Compressor over 125 cu. feet; conveyor belt machine regardless of size; lighting unit (portable & generator); welding machine (steel erection and excavation); and compressor plantstud machine, ladder hoist.

GROUP 4-A: Air tractor drill; batch plant; bending machines; concrete breaker; concrete spreader; curb cutter machine; farm tractor (all types); finishing machine-concrete; hepa vac clean air machine all similar types of removal or asbestos; material hopper-sand-stone-cement; mixer-concrete-under 21E; mulching grass spreader; pump-gypsum, etc., pump-plaster-grout fireproofing; roller under 4 ton; shop mechanic (not employed on job site), spreading and fine grading machine; steel cutting machine; syphone pump-air-steam; tar joint machine; television-cameras-water-sewer-gas-ect, turbo jet burner or similar equipment; vibrator (1 to 5); fine grading machine, roof hoist (tugger hoist).

Federal Wage Rates

GROUP 4-B: Compressor to 125 feet; dust collector; heater all types; pump; pump station (water and sewer); steam jenny and sweeper; chipper; mulcher.

GROUP 5-A: Concrete saw; oiler fuel truck and oiler grease truck.

GROUP 5-B: Oiler; stockroom attendant; paint compressor; motorized roller (walk behind).

GROUP 6-A-1: Master mechanic.

GROUP 6-A-2: Helicopter host operator.

GROUP 6-A-3: Welder certified.

GROUP 6-A-4: Helicopter pilot.

GROUP 6-A-5: Helicopter signalman.

GROUP 6-A-6: Engineer-all tower cranes-all climbing cranes and all cranes of 100 ton capacity or greater (3900 Manitowac or similar) irrespective of manufacturer and regardless of how the same is rigged (except for pile rigs).

GROUP 6-B-1: Utility man.

GROUP 6-B-2: Warehouse man.

GROUP 6-B-3: Second engineer.

GROUP 6-B-4: Cable splicer.

NOTE: Hazmat : 20% above regular wage
Pumping Operation Premium .50
Crane Operators (100-149 ft.) 2.00
Crane Operators (149 ft +) 3.00
Loader Operators (over 5 cu yd) .50
Shovel Operators (over 4 cu yd) 1.00

-----
ENGI0137-006 03/07/2011

HEAVY & HIGHWAY

Table with 3 columns: Group Name, Rates, Fringes. Lists various equipment operator groups and their corresponding rates and fringe benefits.

## Federal Wage Rates

GROUP 5-A-6.....	\$ 43.48	24.37+a
GROUP 5-A-7.....	\$ 43.48	24.37+a
GROUP 5-B-1.....	\$ 31.86	24.37+a
GROUP 5-B-2.....	\$ 36.30	24.37+a
GROUP 5-B-3.....	\$ 31.37	24.37+a

Loader Operator (over 5 cu yd.)	.50
Shovel Operator (over 4 cu yd.)	1.00
Hazmat Premium Over Regular Rate	20%

## FOOTNOTE:

a. PAID HOLIDAYS: New Year's Day; Memorial Day; Independence Day; Labor Day; Thanksgiving Day; Christmas Day; Lincoln's Birthday; Washington's Birthday; Good Friday; Columbus Day; November Election Day and -Veterans Day, provided the employee works two or more days in the calendar week in which the holiday occurs.

## POWER EQUIPMENT OPERATORS CLASSIFICATIONS (HEAVY &amp; HIGHWAY)

GROUP 1: Boom Truck; Cherry Picker; Clamshell; Crane, (Crawler Truck); Dragline; Rough Terrain Crane

GROUP 1-A: Auger; auto grader; dynahoe; dual purpose and similar machines; Boat Captain; Boring Machine (all types); Bull Dozer- all sizes; Central Mix Plant Operator; Chipper-all types; Close Circuit T.V.; Compactor with Blade; Concrete Portable Hoist; C.M.I. or similar; Conway or similar mucking machines; Gradall, Shovell Backhoe, etc. Grader; Derrick (Stone-Steel); Elevator & cage, materials or passengers; Front End Loaders over 1 1/2 yds; Hoist Single, Double, Triple Drum; Hoist Portable Mobile Unit; Hoist Engineer-Concrete (Crane-Derrick-Mine Hoist); Hoist Engineer-Material; Hydraulic Boom; Letourneau or Tournapull (Scrapers over 20 yds. struck); Log Skidder; Movable Concrete Barrier Transfer & Transport Vehicle; Mucking Machines; Overhead Crane; Paver (concrete); Pulsemeter; Push Button (Buzz Box) Elevator; Road Mix Machines; Robot Hammer (Brock or Similar); Robotic Equipment (scope of Engineer schedule); Ross Carrier and similar machines; Shovels (Tunnels); Side Boom; Slip Form Machine; Spreader (Asphalt); Scoopmobile-Tractor-Shovel over 1 1/2 yds; Trenching Machines, Telephies-Vermeer Concrete Saw Trencher and/or similar; Tractor type demolition equipment; Whirly

GROUP 1-B: Road Paver: Asphalt

GROUP 2-A: Balast Regulators; Compactor self-propelled; Cow Tracks; Fusion Machine; Rail Anchor Machines; Roller 4 ton and over; Scrapers--20 yd struck and under; Swich Tampers; Vibratory Roller, etc.; Welder

GROUP 2-B: Mechanic (outside) all types

GROUP 3-A: Air tractor drill; asphalt plant; batch plant; boiler (high pressure; concrete breaker; concrete pump; concrete spreader; curb cutter machine; farm tractor (all types); finishing machine (concrete); fine grading machine;

Federal Wage Rates

fireman; forklift; forklift (electric); John Henry Drill or similar; joy drill or similar tractor drilling machine; loader - 1 1/2 yards and under; locomotive (all sizes), maintenance engineer; machine pulling sheeps foot roller; material hopper; mixer concrete - 21-E and over; mulching grass spreader; portable asphalt plant, portable batch plant, portable crusher; powerhouse plant; quarry master; roller under 4 ton; spreading and fine grading machine; steel cutting machine; stone crusher; sweeper; turbo jet burner or similar ; well drilling machine (except water well drilling); winch truck "A" frame;

GROUP 4-A: Service man (fuel or grease truck).

GROUP 4-B: Compressor-Compressor Plant-Paint; Compressor-Steel Erection; Conveyor Belt machine; Lighting Unit (Portable & Generator); Pilot/Assistant Engineer/2 seated; Pumps-Pump Station-Water-Sewer-Gypsum-Plaster, etc.; Pump Truck (Sewer Jet or Similar); Roller-Motoraized (Walk behind); Welding Machine (Steel Erection); Bending Machine; Dust Collector; Mixer Concrete under 21-E; Heater-all types; Steam Jenny; Syphon Pump-Air- Steam; Tar Joint Machine; Vibrator (1 to 5); Compressor Truck Mounted (2-6)

GROUP 5-A-1: Master Mechanic

GROUP 5-A-2: Helicopter hoist operator.

GROUP 5-A-3: Engineer - all tower cranes, all climbing cranes and all cranes of 100 ton capacity or greater (3900 Manitowac or similar) irrespective of manufacturer and regardless of how the same is rigged (except for pile rigs).

GROUP 5-A-4: Engineer-- Pile Driver

GROUP 5-A-5: Hoist Engineer-Steel-Substructure; Helicopter - pilot.

GROUP 5-A-6: Helicopter - signalman.

GROUP 5-A-7: Jersey-spreader, pavement breaker (air ram); post hole digger;

GROUP 5-B-1: Utility Man

GROUP 5-B-2: Concrete Saw

GROUP 5-B-3: Oiler

-----  
IRON0417-001 07/01/2012

	Rates	Fringes
IRONWORKER.....	\$ 36.70	35.30+a

a) Paid Holidays: New Year's Day, Memorial Day, Fourth of July, Labor Day, Thanksgiving Day, Day after Thanksgiving (unpaid), Christmas Day.

-----  
LABO0060-001 04/01/2012

Federal Wage Rates

	Rates	Fringes
Laborers: (HEAVY)		
GROUP 1.....	\$ 35.80	19.45
GROUP 2.....	\$ 34.45	19.45
GROUP 3.....	\$ 34.05	19.45
GROUP 4.....	\$ 33.70	19.45
GROUP 5.....	\$ 33.35	19.45
GROUP 6.....	\$ 27.00	19.45
GROUP 7.....	\$ 35.35	19.45

LABORERS CLASSIFICATIONS (HEAVY):

GROUP 1: Blasters.

GROUP 2: Burner, Jumbo Driller, Joy Driller, Wagon Driller, Air Track Driller, Hydraulic Driller, Concrete Form Aligner, Concrete Form and Curb Form (Steel), Asphalt Screedman, Asphalt Raker.

GROUP 3: Asphalt Curb Machine Operator, Jeeper Operator, Pavement Breaker Operator, Power Saw Operator, Jack Hammer Driller. All types of pneumatic tools gasoline driller, concrete saw, gunniting, railroad spike puller and sandblasting, pipe layer, deck winches on scows, power buggy operator, power wheelbarrow operator.

GROUP 4: General concrete laborers-anything pertaining to concrete, aggregate or concrete material handling, puddlers, asphalt worker, rock scalers, vibrator operator, bit grinder, concrete grinder, air tampers and all tampers not covered by any other classification, form pin puller, pumps and their operation, service of air power, epoxy and waterproofing worker, fine grade person between forms, barco rammer, guard and guide rail and link fence, steel kings.

GROUP 5: Common laborers, signal person and pit person , truck spotters, powder person, landscape and nursery person, dump person.

GROUP 6: Flagperson

GROUP 7: Asbestos and Toxic Waste laborer

FOOTNOTE:

a. PAID HOLIDAYS: New Year's Day, Lincoln's Birthday, Washington's Birthday, Good Friday, Memorial Day, Independence Day, Labor Day, Columbus Day, November Election Day, Veteran's Day, Thanksgiving Day and Christmas Day.

LABO0235-001 05/01/2002

BUILDING

Rates	Fringes
-------	---------

Federal Wage Rates

LABORER.....\$ 23.50 13.85

LABO1000-003 05/01/2009

Table with 3 columns: Rates, Fringes, and Laborers: (HIGHWAY) GROUP 1-3 with corresponding rates and fringes.

FOOTNOTE:

a. PAID HOLIDAYS: New Years Day, Presidents Day, Good Friday, Memorial Day, Independence Day, Labor Day, Columbus Day, Veteran's Day, November Election Day, Thanksgiving Day and Christmas Day

LABORERS CLASSIFICATIONS (HIGHWAY)

GROUP 1: Flagperson, placing and maintenance of all flares, cones, lights, signs, barricades, traffic patterns, and all reflective type materials for traffic control, custodial work, traffic directors, temporary heat or light tenders

GROUP 2: General Laborers, Dumpman, Pitman, Concrete man, Signal Man, Pipelayer, Rip Rap, Dry Stone Layer, Jack Hammer, Powderman, Highscalers Power Buggy Operator, Steel Rod Carrier, Vibratory Operator, Other Machine Operator, Wrecking, Vibrator Operator-Compactor, Guniting and Sand Blasting, Water Pump 2" or under, Nipper, Chucker, Asphalt Worker

GROUP 3: Asphalt Raker, Asphalt Screeman, Drillers (all), Laser Beam Operator, Form Setter/Aligners, Blasters, Lead Man, Tunnel & Caisson

\* PAIN0009-003 05/01/2012

Table with 3 columns: Rates, Fringes, and Painters: GLAZIERS, Abatement Worker, Spray, Scaffold, Sandblasting with corresponding rates and fringes.

PLUM0021-001 05/01/2011

Table with 3 columns: Rates, Fringes, and Plumber and Steamfitter Zone 1 with corresponding rates and fringes.

ROOF0008-002 06/01/2010

Rates Fringes

Federal Wage Rates

ROOFER.....\$ 37.75 28.86

SFNY0669-002 04/01/2012

Rates Fringes

SPRINKLER FITTER.....\$ 39.08 20.65

SHEE0038-001 07/01/2012

Rates Fringes

Sheet metal worker.....\$ 41.81 31.85

TEAM0456-001 07/01/2011

HEAVY & HIGHWAY CONSTRUCION

Rates Fringes

Truck drivers:

Table with 3 columns: GROUP, Rates, Fringes. Rows 1-12 showing rates ranging from \$37.27 to \$40.02 and fringes at 20.75.

Hazardous/Toxic Waste - An additional 20% of the basic hourly wage rate set forth in this wage determination.

CLASSIFICATION DESCRIPTIONS

- GROUP 1: Lowboy (carrying equipment)
GROUP 2: Straight jobs: 6-Wheeler, 10-Wheeler, A-Frame Trucks (inside cab), Winch Truck (inside cab), Dynamite Truck, Seeding Truck, Mulching Truck, Agitator Truck, Water Truck, Cement Trucks (all types), Suburbans, Station Wagons, Cars, Pickups.
GROUP 3: Fuel and tire trucks.
GROUP 4: Tractor trailers (all types)
GROUP 5: 14 Wheeler
GROUP 6: Athey wagon, Belly dumps, Articulated Dumps, Trailer wagons.
GROUP 7: Athey Wagon, Belly Dumps, Articulated Dumps, Trailer Wagons.
GROUP 8: Darts.
GROUP 9: RXS
GROUP 10: Off Road Equipment (Under 40 Tons): Euclid
GROUP 11: Off Road Equipment (Over 40 Tons) Euclid, DJB
GROUP 12: Off Road Equipment (Under 40 Tons) DJB

a. PAID HOLIDAYS: New Year's Day, Lincoln's Birthday, President's Day, Decoration Day, Independence Day, Labor



Federal Wage Rates

Day, November Election Day, Thanksgiving Day, Day after Thanksgiving and Christmas Day, provided employee works two or more days in the calendar week in which the holiday falls.

PAID VACATION: 4 weeks paid vacation after 20 years of service and 30 days of employment in current contract year; 3 weeks after 10 years of seniority service; 3 weeks after 10 years and 60 days of employment in contract year, 3 weeks and 1 day after 16 years of seniority service, 3 weeks and 2 days after 17 years of seniority service; 3 weeks and 3 days after 18 years of seniority service; 3 weeks and 4 days after 19 years of seniority service; The third week and every additional day shall be granted to employee in the calendar year in which he completes his tenth or other years of seniority service; 2 weeks after 130 days of employment in the calendar year; 2 weeks after 5 years and 90 days seniority service in calander year; 1 week and 1 additional day for each additional 18 days of employment not exceeding 10 days in any one calander year after 90 days of employment. Casual employees 1 day for every 18 days of employment. An employee who does not qualify for vacation shall be paid pro rata on a daily basis. Holiday shall be counted as days worked for vacation benefits.

LEGAL SERVICES FUND: Employer shall contribute \$.20 to the fund on the same basis for all hours paid to employees in the form of holiday pay or vacation pay. In addition to the benefits paid for Health-Welfare and Pension for up to 40 hours worked an additional \$.25 is paid for each hour worked. The employer shall grant 3 calendar days off without loss of pay to an employee who has death in his/her immediate family, inclusive of the day of the funeral.

-----  
WELDERS - Receive rate prescribed for craft performing operation to which welding is incidental.  
=====

Unlisted classifications needed for work not included within the scope of the classifications listed may be added after award only as provided in the labor standards contract clauses (29CFR 5.5 (a) (1) (ii)).  
-----

The body of each wage determination lists the classification and wage rates that have been found to be prevailing for the cited type(s) of construction in the area covered by the wage determination. The classifications are listed in alphabetical order of "identifiers" that indicate whether the particular rate is union or non-union.

Union Identifiers

### Federal Wage Rates

An identifier enclosed in dotted lines beginning with characters other than "SU" denotes that the union classification and rate have found to be prevailing for that classification. Example: PLUM0198-005 07/01/2011. The first four letters, PLUM, indicate the international union and the four-digit number, 0198, that follows indicates the local union number or district council number where applicable, i.e., Plumbers Local 0198. The next number, 005 in the example, is an internal number used in processing the wage determination. The date, 07/01/2011, following these characters is the effective date of the most current negotiated rate/collective bargaining agreement which would be July 1, 2011 in the above example.

Union prevailing wage rates will be updated to reflect any changes in the collective bargaining agreements governing the rate.

#### Non-Union Identifiers

Classifications listed under an "SU" identifier were derived from survey data by computing average rates and are not union rates; however, the data used in computing these rates may include both union and non-union data. Example: SULA2004-007 5/13/2010. SU indicates the rates are not union rates, LA indicates the State of Louisiana; 2004 is the year of the survey; and 007 is an internal number used in producing the wage determination. A 1993 or later date, 5/13/2010, indicates the classifications and rates under that identifier were issued as a General Wage Determination on that date.

Survey wage rates will remain in effect and will not change until a new survey is conducted.

---

#### WAGE DETERMINATION APPEALS PROCESS

1.) Has there been an initial decision in the matter? This can be:

- \* an existing published wage determination
- \* a survey underlying a wage determination
- \* a Wage and Hour Division letter setting forth a position on a wage determination matter
- \* a conformance (additional classification and rate) ruling

On survey related matters, initial contact, including requests for summaries of surveys, should be with the Wage and Hour Regional Office for the area in which the survey was conducted because those Regional Offices have responsibility for the Davis-Bacon survey program. If the response from this initial contact is not satisfactory, then the process described in 2.) and 3.) should be followed.

With regard to any other matter not yet ripe for the formal process described here, initial contact should be with the Branch of Construction Wage Determinations. Write to:

**Federal Wage Rates**

Branch of Construction Wage Determinations  
Wage and Hour Division  
U.S. Department of Labor  
200 Constitution Avenue, N.W.  
Washington, DC 20210

2.) If the answer to the question in 1.) is yes, then an interested party (those affected by the action) can request review and reconsideration from the Wage and Hour Administrator (See 29 CFR Part 1.8 and 29 CFR Part 7). Write to:

Wage and Hour Administrator  
U.S. Department of Labor  
200 Constitution Avenue, N.W.  
Washington, DC 20210

The request should be accompanied by a full statement of the interested party's position and by any information (wage payment data, project description, area practice material, etc.) that the requestor considers relevant to the issue.

3.) If the decision of the Administrator is not favorable, an interested party may appeal directly to the Administrative Review Board (formerly the Wage Appeals Board). Write to:

Administrative Review Board  
U.S. Department of Labor  
200 Constitution Avenue, N.W.  
Washington, DC 20210

4.) All decisions by the Administrative Review Board are final.

=====

END OF GENERAL DECISION

**D262100**  
**SPECIAL NOTE**  
**STATE PREVAILING WAGE RATES**

The New York State Department of Labor (NYSDOL) has issued a project-specific prevailing wage rate schedule for this Contract. The New York State Labor Law requires the Contractor and all subcontractors to ensure that all workers employed in the performance of a public work contract are paid not less than the prevailing wage rate and supplemental (fringe) benefits in the locality where the work is performed.

The project-specific prevailing wage rate schedule, together with all updates and amendments, is incorporated by reference in this Contract, and made a part hereof, as though fully set forth herein. The schedule may be accessed by visiting the NYSDOL website, navigating to the appropriate web page for prevailing wages, and entering the Prevailing Rate Case Number (PRC#). The PRC# is found on NYSDOL Form PW-200, the following page in this Contract Proposal. The project-specific prevailing wage rate schedule and all wage rate amendments are annexed electronically through the following link:

[www.labor.ny.gov](http://www.labor.ny.gov)

It is the obligation of the Contractor and all subcontractors to obtain all updated prevailing wage rate schedules and to pay all workers in accordance with the periodic wage rate schedule updates issued by the NYSDOL. Any changes or clarifications of labor classifications, and information on the applicability of particular prevailing wage rates, must be obtained from the Office of the Director of the Bureau of Public Work at the New York State Department of Labor.



Andrew M. Cuomo, Governor

Peter M. Rivera, Commissioner

NYS DOT
Anthony Chiffole, Civil Engineer 2
POD 23
50 Wolf Road
Albany NY 12232

Schedule Year 2012 through 2013
Date Requested 08/07/2012
PRC# 2012006959

Location SH 64-06
Project ID# D262100
Project Type Bridge Replacements. PIN 8062.10

PREVAILING WAGE SCHEDULE FOR ARTICLE 8 PUBLIC WORK PROJECT

Attached is the current schedule(s) of the prevailing wage rates and prevailing hourly supplements for the project referenced above. A unique Prevailing Wage Case Number (PRC#) has been assigned to the schedule(s) for your project.

The schedule is effective from July 2012 through June 2013. All updates, corrections, posted on the 1st business day of each month, and future copies of the annual determination are available on the Department's website www.labor.state.ny.us. Updated PDF copies of your schedule can be accessed by entering your assigned PRC# at the proper location on the website.

It is the responsibility of the contracting agency or its agent to annex and make part, the attached schedule, to the specifications for this project, when it is advertised for bids and /or to forward said schedules to the successful bidder(s), immediately upon receipt, in order to insure the proper payment of wages.

Please refer to the "General Provisions of Laws Covering Workers on Public Work Contracts" provided with this schedule, for the specific details relating to other responsibilities of the Department of Jurisdiction.

Upon completion or cancellation of this project, enter the required information and mail OR fax this form to the office shown at the bottom of this notice, OR fill out the electronic version via the NYSDOL website.

NOTICE OF COMPLETION / CANCELLATION OF PROJECT

Date Completed: \_\_\_\_\_ Date Cancelled: \_\_\_\_\_
Name & Title of Representative: \_\_\_\_\_

Phone: (518) 457-5589 Fax: (518) 485-1870
W. Averell Harriman State Office Campus, Bldg. 12, Room 130, Albany, NY 12240

## General Provisions of Laws Covering Workers on Article 8 Public Work Contracts

### Introduction

The Labor Law requires public work contractors and subcontractors to pay laborers, workers, or mechanics employed in the performance of a public work contract not less than the prevailing rate of wage and supplements (fringe benefits) in the locality where the work is performed.

### Responsibilities of the Department of Jurisdiction

A Department of Jurisdiction (Contracting Agency) includes a state department, agency, board or commission; a county, city, town or village; a school district, board of education or board of cooperative educational services; a sewer, water, fire, improvement and other district corporation; a public benefit corporation; and a public authority awarding a public work contract.

The Department of Jurisdiction (Contracting Agency) awarding a public work contract MUST obtain a Prevailing Rate Schedule listing the hourly rates of wages and supplements due the workers to be employed on a public work project. This schedule may be obtained by completing and forwarding a "Request for wage and Supplement Information" form (PW 39) to the Bureau of Public Work. The Prevailing Rate Schedule MUST be included in the specifications for the contract to be awarded and is deemed part of the public work contract.

Upon the awarding of the contract, the law requires that the Department of Jurisdiction (Contracting Agency) furnish the following information to the Bureau: the name and address of the contractor, the date the contract was let and the approximate dollar value of the contract. To facilitate compliance with this provision of the Labor Law, a copy of the Department's "Notice of Contract Award" form (PW 16) is provided with the original Prevailing Rate Schedule.

The Department of Jurisdiction (Contracting Agency) is required to notify the Bureau of the completion or cancellation of any public work project. The Department's PW 200 form is provided for that purpose.

Both the PW 16 and PW 200 forms are available for completion [online](#).

### Hours

No laborer, worker, or mechanic in the employ of a contractor or subcontractor engaged in the performance of any public work project shall be permitted to work more than eight hours in any day or more than five days in any week, except in cases of extraordinary emergency. The contractor and the Department of Jurisdiction (Contracting Agency) may apply to the Bureau of Public Work for a dispensation permitting workers to work additional hours or days per week on a particular public work project.

There are very few exceptions to this rule. Complete information regarding these exceptions is available on the "[4 Day / 10 Hour Work Schedule](#)" form (PW 30R).

### Wages and Supplements

The wages and supplements to be paid and/or provided to laborers, workers, and mechanics employed on a public work project shall be not less than those listed in the current Prevailing Rate Schedule for the locality where the work is performed. If a prime contractor on a public work project has not been provided with a Prevailing Rate Schedule, the contractor must notify the Department of Jurisdiction (Contracting Agency) who in turn must request an original Prevailing Rate Schedule form the Bureau of Public Work. Requests may be submitted by: mail to NYSDOL, Bureau of Public Work, State Office Bldg. Campus, Bldg. 12, Rm. 130, Albany, NY 12240; Fax to Bureau of Public Work (518) 485-1870; or electronically at the NYSDOL website [www.labor.state.ny.us](http://www.labor.state.ny.us).

Upon receiving the original schedule, the Department of Jurisdiction (Contracting Agency) is REQUIRED to provide complete copies to all prime contractors who in turn MUST, by law, provide copies of all applicable county schedules to each subcontractor and obtain from each subcontractor, an affidavit certifying such schedules were received. If the original schedule expired, the contractor may obtain a copy of the new annual determination from the NYSDOL website [www.labor.state.ny.us](http://www.labor.state.ny.us).

The Commissioner of Labor makes an annual determination of the prevailing rates. This determination is in effect from July 1st through June 30th of the following year. The annual determination is available on the NYSDOL website [www.labor.state.ny.us](http://www.labor.state.ny.us).

### Payrolls and Payroll Records

Every contractor and subcontractor MUST keep original payrolls or transcripts subscribed and affirmed as true under penalty of perjury. Payrolls must be maintained for at least three (3) years from the project's date of completion. At a minimum, payrolls must show the following information for each person employed on a public work project: Name, Address, Last 4 Digits of Social Security Number, Classification(s) in which the worker was employed, Hourly wage rate(s) paid, Supplements paid or provided, and Daily and weekly number of hours worked in each classification.

Every contractor and subcontractor shall submit to the Department of Jurisdiction (Contracting Agency), within thirty (30) days after issuance of its first payroll and every thirty (30) days thereafter, a transcript of the original payrolls, subscribed and affirmed as true under penalty of perjury. The Department of Jurisdiction (Contracting Agency) shall collect, review for facial validity, and maintain such payrolls.

In addition, the Commissioner of Labor may require contractors to furnish, with ten (10) days of a request, payroll records sworn to as their validity and accuracy for public work and private work. Payroll records include, but are not limited to time cards, work description sheets, proof that supplements were provided, cancelled payroll checks and payrolls. Failure to provide the requested information within the allotted ten (10) days will result in the withholding of up to 25% of the contract, not to exceed \$100,000.00. If the contractor or subcontractor does not maintain a place of business in New York State and the amount of the contract exceeds \$25,000.00, payroll records and certifications must be kept on the project worksite.

The prime contractor is responsible for any underpayments of prevailing wages or supplements by any subcontractor.

All contractors or their subcontractors shall provide to their subcontractors a copy of the Prevailing Rate Schedule specified in the public work contract as well as any subsequently issued schedules. A failure to provide these schedules by a contractor or subcontractor is a violation of Article 8, Section 220-a of the Labor Law.

All subcontractors engaged by a public work project contractor or its subcontractor, upon receipt of the original schedule and any subsequently issued schedules, shall provide to such contractor a verified statement attesting that the subcontractor has received the Prevailing Rate Schedule and will pay or provide the applicable rates of wages and supplements specified therein. (See NYS Labor Laws, Article 8 . Section 220-a).

### **Determination of Prevailing Wage and Supplement Rate Updates Applicable to All Counties**

The wages and supplements contained in the annual determination become effective July 1st whether or not the new determination has been received by a given contractor. Care should be taken to review the rates for obvious errors. Any corrections should be brought to the Department's attention immediately. It is the responsibility of the public work contractor to use the proper rates. If there is a question on the proper classification to be used, please call the district office located nearest the project. Any errors in the annual determination will be corrected and posted to the NYS DOL website on the first business day of each month. Contractors are responsible for paying these updated rates as well, retroactive to July 1st.

When you review the schedule for a particular occupation, your attention should be directed to the dates above the column of rates. These are the dates for which a given set of rates is effective. To the extent possible, the Department posts rates in its possession that cover periods of time beyond the July 1st to June 30th time frame covered by a particular annual determination. Rates that extend beyond that instant time period are informational ONLY and may be updated in future annual determinations that actually cover the then appropriate July 1st to June 30th time period.

### **Withholding of Payments**

When a complaint is filed with the Commissioner of Labor alleging the failure of a contractor or subcontractor to pay or provide the prevailing wages or supplements, or when the Commissioner of Labor believes that unpaid wages or supplements may be due, payments on the public work contract shall be withheld from the prime contractor in a sufficient amount to satisfy the alleged unpaid wages and supplements, including interest and civil penalty, pending a final determination.

When the Bureau of Public Work finds that a contractor or subcontractor on a public work project failed to pay or provide the requisite prevailing wages or supplements, the Bureau is authorized by Sections 220-b and 235.2 of the Labor Law to so notify the financial officer of the Department of Jurisdiction (Contracting Agency) that awarded the public work contract. Such officer MUST then withhold or cause to be withheld from any payment due the prime contractor on account of such contract the amount indicated by the Bureau as sufficient to satisfy the unpaid wages and supplements, including interest and any civil penalty that may be assessed by the Commissioner of Labor. The withholding continues until there is a final determination of the underpayment by the Commissioner of Labor or by the court in the event a legal proceeding is instituted for review of the determination of the Commissioner of Labor.

The Department of Jurisdiction (Contracting Agency) shall comply with this order of the Commissioner of Labor or of the court with respect to the release of the funds so withheld.

### **Summary of Notice Posting Requirements**

The current Prevailing Rate Schedule must be posted in a prominent and accessible place on the site of the public work project. The prevailing wage schedule must be encased in, or constructed of, materials capable of withstanding adverse weather conditions and be titled "PREVAILING RATE OF WAGES" in letters no smaller than two (2) inches by two (2) inches.

The "[Public Work Project](#)" notice must be posted at the beginning of the performance of every public work contract, on each job site.

Every employer providing workers' compensation insurance and disability benefits must post notices of such coverage in the format prescribed by the Workers' Compensation Board in a conspicuous place on the jobsite.

Every employer subject to the NYS Human Rights Law must conspicuously post at its offices, places of employment, or employment training centers, notices furnished by the State Division of Human Rights.

Employers liable for contributions under the Unemployment Insurance Law must conspicuously post on the jobsite notices furnished by the NYS Department of Labor.

### **Apprentices**

Employees cannot be paid apprentice rates unless they are individually registered in a program registered with the NYS Commissioner of Labor. The allowable ratio of apprentices to journeyworkers in any craft classification can be no greater than the statewide building trade ratios promulgated by the Department of Labor and included with the Prevailing Rate Schedule. An employee listed on a payroll as an apprentice who is not registered as above or is performing work outside the classification of work for which the apprentice is indentured, must be paid the prevailing journeyworker's wage rate for the classification of work the employee is actually performing.

NYS DOL Labor Law, Article 8, Section 220-3, require that only apprentices individually registered with the NYS Department of Labor may be paid apprenticeship rates on a public work project. No other Federal or State Agency of office registers apprentices in New York State.

Persons wishing to verify the apprentice registration of any person must do so in writing by mail, to the NYSDOL Office of Employability Development / Apprenticeship Training, State Office Bldg. Campus, Bldg. 12, Albany, NY 12240 or by Fax to NYSDOL Apprenticeship Training (518) 457-7154. All requests for verification must include the name and social security number of the person for whom the information is requested.

The only conclusive proof of individual apprentice registration is written verification from the NYSDOL Apprenticeship Training Albany Central office. Neither Federal nor State Apprenticeship Training offices outside of Albany can provide conclusive registration information.

It should be noted that the existence of a registered apprenticeship program is not conclusive proof that any person is registered in that program. Furthermore, the existence or possession of wallet cards, identification cards, or copies of state forms is not conclusive proof of the registration of any person as an apprentice.

### **Interest and Penalties**

In the event that an underpayment of wages and/or supplements is found:

- Interest shall be assessed at the rate then in effect as prescribed by the Superintendent of Banks pursuant to section 14-a of the Banking Law, per annum from the date of underpayment to the date restitution is made.
- A Civil Penalty may also be assessed, not to exceed 25% of the total of wages, supplements, and interest due.

### **Debarment**

Any contractor or subcontractor and/or its successor shall be ineligible to submit a bid on or be awarded any public work contract or subcontract with any state, municipal corporation or public body for a period of five (5) years when:

- Two (2) willful determinations have been rendered against that contractor or subcontractor and/or its successor within any consecutive six (6) year period.
- There is any willful determination that involves the falsification of payroll records or the kickback of wages or supplements.

### **Criminal Sanctions**

Willful violations of the Prevailing Wage Law (Article 8 of the Labor Law) may be a felony punishable by fine or imprisonment of up to 15 years, or both.

### **Discrimination**

No employee or applicant for employment may be discriminated against on account of age, race, creed, color, national origin, sex, disability or marital status.

No contractor, subcontractor nor any person acting on its behalf, shall by reason of race, creed, color, disability, sex or national origin discriminate against any citizen of the State of New York who is qualified and available to perform the work to which the employment relates (NYS Labor Law, Article 8, Section 220-e(a)).

No contractor, subcontractor, nor any person acting on its behalf, shall in any manner, discriminate against or intimidate any employee on account of race, creed, color, disability, sex, or national origin (NYS Labor Law, Article 8, Section 220-e(b)).



The Human Rights Law also prohibits discrimination in employment because of age, marital status, or religion.

There may be deducted from the amount payable to the contractor under the contract a penalty of \$50.00 for each calendar day during which such person was discriminated against or intimidated in violation of the provision of the contract (NYS Labor Law, Article 8, Section 220-e(c) ).

The contract may be cancelled or terminated by the State or municipality. All monies due or to become due thereunder may be forfeited for a second or any subsequent violation of the terms or conditions of the anti-discrimination sections of the contract (NYS Labor Law, Article 8, Section 220-e(d) ).

Every employer subject to the New York State Human Rights Law must conspicuously post at its offices, places of employment, or employment training centers notices furnished by the State Division of Human Rights.

### **Workers' Compensation**

In accordance with Section 142 of the State Finance Law, the contractor shall maintain coverage during the life of the contract for the benefit of such employees as required by the provisions of the New York State Workers' Compensation Law.

A contractor who is awarded a public work contract must provide proof of workers' compensation coverage prior to being allowed to begin work.

The insurance policy must be issued by a company authorized to provide workers' compensation coverage in New York State. Proof of coverage must be on form C-105.2 (Certificate of Workers' Compensation Insurance) and must name this agency as a certificate holder.

If New York State coverage is added to an existing out-of-state policy, it can only be added to a policy from a company authorized to write workers' compensation coverage in this state. The coverage must be listed under item 3A of the information page.

The contractor must maintain proof that subcontractors doing work covered under this contract secured and maintained a workers' compensation policy for all employees working in New York State.

Every employer providing worker's compensation insurance and disability benefits must post notices of such coverage in the format prescribed by the Workers' Compensation Board in a conspicuous place on the jobsite.

### **Unemployment Insurance**

Employers liable for contributions under the Unemployment Insurance Law must conspicuously post on the jobsite notices furnished by the New York State Department of Labor.

**To all State Departments, Agency Heads and Public Benefit Corporations  
IMPORTANT NOTICE REGARDING PUBLIC WORK ENFORCEMENT FUND**

## **Budget Policy & Reporting Manual**

# **B-610**

### **Public Work Enforcement Fund**

*effective date December 7, 2005*

---

#### **1. Purpose and Scope:**

This Item describes the Public Work Enforcement Fund (the Fund, PWEF) and its relevance to State agencies and public benefit corporations engaged in construction or reconstruction contracts, maintenance and repair, and announces the recently-enacted increase to the percentage of the dollar value of such contracts that must be deposited into the Fund. This item also describes the roles of the following entities with respect to the Fund:

- New York State Department of Labor (DOL),
- The Office of the State of Comptroller (OSC), and
- State agencies and public benefit corporations.

#### **2. Background and Statutory References:**

DOL uses the Fund to enforce the State's Labor Law as it relates to contracts for construction or reconstruction, maintenance and repair, as defined in subdivision two of Section 220 of the Labor Law. State agencies and public benefit corporations participating in such contracts are required to make payments to the Fund.

Chapter 511 of the Laws of 1995 (as amended by Chapter 513 of the Laws of 1997, Chapter 655 of the Laws of 1999, Chapter 376 of the Laws of 2003 and Chapter 407 of the Laws of 2005) established the Fund.

#### **3. Procedures and Agency Responsibilities:**

The Fund is supported by transfers and deposits based on the value of contracts for construction and reconstruction, maintenance and repair, as defined in subdivision two of Section 220 of the Labor Law, into which all State agencies and public benefit corporations enter.

Chapter 407 of the Laws of 2005 increased the amount required to be provided to this fund to .10 of one-percent of the total cost of each such contract, to be calculated at the time agencies or public benefit corporations enter into a new contract or if a contract is amended. The provisions of this bill became effective August 2, 2005.

**To all State Departments, Agency Heads and Public Benefit Corporations  
IMPORTANT NOTICE REGARDING PUBLIC WORK ENFORCEMENT FUND**

OSC will report to DOL on all construction-related ("D") contracts approved during the month, including contract amendments, and then DOL will bill agencies the appropriate assessment monthly. An agency may then make a determination if any of the billed contracts are exempt and so note on the bill submitted back to DOL. For any instance where an agency is unsure if a contract is or is not exempt, they can call the Bureau of Public Work at the number noted below for a determination. Payment by check or journal voucher is due to DOL within thirty days from the date of the billing. DOL will verify the amounts and forward them to OSC for processing.

For those contracts which are not approved or administered by the Comptroller, monthly reports and payments for deposit into the Public Work Enforcement Fund must be provided to the Administrative Finance Bureau at the DOL within 30 days of the end of each month or on a payment schedule mutually agreed upon with DOL.

Reports should contain the following information:

- Name and billing address of State agency or public benefit corporation;
- State agency or public benefit corporation contact and phone number;
- Name and address of contractor receiving the award;
- Contract number and effective dates;
- Contract amount and PWEF assessment charge (if contract amount has been amended, reflect increase or decrease to original contract and the adjustment in the PWEF charge); and
- Brief description of the work to be performed under each contract.

Checks and Journal Vouchers, payable to the "New York State Department of Labor" should be sent to:

Department of Labor  
Administrative Finance Bureau-PWEF Unit  
Building 12, Room 464  
State Office Campus  
Albany, NY 12240

Any questions regarding billing should be directed to NYSDOL's Administrative Finance Bureau-PWEF Unit at (518) 457-3624 and any questions regarding Public Work Contracts should be directed to the Bureau of Public Work at (518) 457-5589.

## Introduction to the Prevailing Rate Schedule

### Information About Prevailing Rate Schedule

This information is provided to assist you in the interpretation of particular requirements for each classification of worker contained in the attached Schedule of Prevailing Rates.

#### Classification

It is the duty of the Commissioner of Labor to make the proper classification of workers taking into account whether the work is heavy and highway, building, sewer and water, tunnel work, or residential, and to make a determination of wages and supplements to be paid or provided. It is the responsibility of the public work contractor to use the proper rate. If there is a question on the proper classification to be used, please call the district office located nearest the project. District office locations and phone numbers are listed below.

Prevailing Wage Schedules are issued separately for "General Construction Projects" and "Residential Construction Projects" on a county-by-county basis.

General Construction Rates apply to projects such as: Buildings, Heavy & Highway, and Tunnel and Water & Sewer rates.

Residential Construction Rates generally apply to construction, reconstruction, repair, alteration, or demolition of one family, two family, row housing, or rental type units intended for residential use.

Some rates listed in the Residential Construction Rate Schedule have a very limited applicability listed along with the rate. Rates for occupations or locations not shown on the residential schedule must be obtained from the General Construction Rate Schedule. Please contact the local Bureau of Public Work office before using Residential Rate Schedules, to ensure that the project meets the required criteria.

#### Paid Holidays

Paid Holidays are days for which an eligible employee receives a regular day's pay, but is not required to perform work. If an employee works on a day listed as a paid holiday, this remuneration is in addition to payment of the required prevailing rate for the work actually performed.

#### Overtime

At a minimum, all work performed on a public work project in excess of eight hours in any one day or more than five days in any workweek is overtime. However, the specific overtime requirements for each trade or occupation on a public work project may differ. Specific overtime requirements for each trade or occupation are contained in the prevailing rate schedules.

Overtime holiday pay is the premium pay that is required for work performed on specified holidays. It is only required where the employee actually performs work on such holidays.

The applicable holidays are listed under HOLIDAYS: OVERTIME. The required rate of pay for these covered holidays can be found in the OVERTIME PAY section listings for each classification.

#### Supplemental Benefits

Particular attention should be given to the supplemental benefit requirements. Although in most cases the payment or provision of supplements is for each hour worked, some classifications require the payment or provision of supplements for each hour paid (including paid holidays on which no work is performed) and/or may require supplements to be paid or provided at a premium rate for premium hours worked.

#### Effective Dates

When you review the schedule for a particular occupation, your attention should be directed to the dates above the column of rates. These are the dates for which a given set of rates is effective. The rate listed is valid until the next effective rate change or until the new annual determination which takes effect on July 1 of each year. All contractors and subcontractors are required to pay the current prevailing rates of wages and supplements. If you have any questions please contact the Bureau of Public Work or visit the New York State Department of Labor website ([www.labor.state.ny.us](http://www.labor.state.ny.us)) for current wage rate information.

#### Apprentice Training Ratios

The following are the allowable ratios of registered Apprentices to Journey-workers.

For example, the ratio 1:1,1:3 indicates the allowable initial ratio is one Apprentice to one Journeyworker. The Journeyworker must be in place on the project before an Apprentice is allowed. Then three additional Journeyworkers are needed before a second Apprentice is allowed. The last ratio repeats indefinitely. Therefore, three more Journeyworkers must be present before a third Apprentice can be hired, and so on.

Please call Apprentice Training Central Office at (518) 457-6820 if you have any questions.

Title (Trade)	Ratio
Boilermaker (Construction)	1:1,1:4
Boilermaker (Shop)	1:1,1:3
Carpenter (Bldg.,H&H, Pile Driver/Dockbuilder)	1:1,1:4
Carpenter (Residential)	1:1,1:3
Electrical (Outside) Lineman	1:1,1:2

Electrician (Inside)	1:1,1:3
Elevator/Escalator Construction & Modernizer	1:1,1:2
Glazier	1:1,1:3
Insulation & Asbestos Worker	1:1,1:3
Iron Worker	1:1,1:4
Laborer	1:1,1:3
Mason	1:1,1:4
Millwright	1:1,1:4
Op Engineer	1:1,1:5
Painter	1:1,1:3
Plumber & Steamfitter	1:1,1:3
Roofer	1:1,1:2
Sheet Metal Worker	1:1,1:3
Sprinkler Fitter	1:1,1:2

If you have any questions concerning the attached schedule or would like additional information, please contact the nearest BUREAU of PUBLIC WORK District Office or write to:

New York State Department of Labor  
 Bureau of Public Work  
 State Office Campus, Bldg. 12  
 Albany, NY 12240

District Office Locations:	Telephone #	FAX #
Bureau of Public Work - Albany	518-457-2744	518-485-0240
Bureau of Public Work - Binghamton	607-721-8005	607-721-8004
Bureau of Public Work - Buffalo	716-847-7159	716-847-7650
Bureau of Public Work - Garden City	516-228-3915	516-794-3518
Bureau of Public Work - Newburgh	845-568-5287	845-568-5332
Bureau of Public Work - New York City	212-775-3568	212-775-3579
Bureau of Public Work - Patchogue	631-687-4882	631-687-4904
Bureau of Public Work - Rochester	585-258-4505	585-258-4708
Bureau of Public Work - Syracuse	315-428-4056	315-428-4671
Bureau of Public Work - Utica	315-793-2314	315-793-2514
Bureau of Public Work - White Plains	914-997-9507	914-997-9523
Bureau of Public Work - Central Office	518-457-5589	518-485-1870



PAGE: 1  
DATE: 08/30/2012

QUANTITY SHEET SUMMARY FOR PROPOSAL

CONTRACT ID: D262100

PROJECT(S): 806210

CONTRACTOR :

SEC NUM	ITEM NUMBER	DESCRIPTION	UNIT	QUANTITY
0001	201.06	CLEARING AND GRUBBING	LS	1.000
0001	202.120001	REMOVING EXISTING SUPERSTRUCTURES	LS	1.000
0001	202.120002	REMOVING EXISTING SUPERSTRUCTURES	LS	1.000
0001	202.19	REMOVAL OF SUBSTRUCTURES	CY	122.000
0001	203.02	UNCLASSIFIED EXCAVATION AND DISPOSAL	CY	13250.000
0001	203.03	EMBANKMENT IN PLACE	CY	12500.000
0001	203.07	SELECT GRANULAR FILL	CY	400.000
0001	203.21	SELECT STRUCTURE FILL	CY	374.000
0001	204.01	CONTROLLED LOW STRENGTH MATERIAL (CLSM)	CY	1472.000
0001	206.01	STRUCTURE EXCAVATION	CY	1092.000
0001	206.04	TRENCH AND CULVERT EXCAVATION - O.G.	CY	835.000
0001	207.20	GEOTEXTILE BEDDING	SY	840.000
0001	207.22	GEOTEXTILE DRAINAGE	SY	200.000
0001	207.26	PREFABRICATED COMPOSITE STRUCTURAL DRAIN	SY	382.000
0001	207.96000017	GEOSYNTHETIC REINFORCEMENT	SF	36.000
0001	209.100101	MULCH - TEMPORARY	SY	44000.000
0001	209.1003	SEED AND MULCH - TEMPORARY	SY	22000.000
0001	209.110102	CHECK DAM (DITCH BOTTOM WIDTH > 3' TO 6'), STONE-TEMP	EACH	3.000
0001	209.1105	CHECK DAM, PREFABRICATED - TEMPORARY	LF	30.000
0001	209.1106	CHECK DAM, STONE-PERMANENT	EACH	4.000
0001	209.13	SILT FENCE-TEMPORARY	LF	6620.000

PAGE: 2  
DATE: 08/30/2012

QUANTITY SHEET SUMMARY FOR PROPOSAL

CONTRACT ID: D262100

PROJECT(S): 806210

CONTRACTOR :

SEC NUM	ITEM NUMBER	DESCRIPTION	UNIT	QUANTITY
0001	209.1704	DRAINAGE STRUCTURE INLET PROTECTION, CONCRETEBLOCK-TE	LF	450.000
0001	209.200301	TURF REINFORCEMENT MATS, CLASS III TYPE C, PERMANENT	SY	5250.000
0001	209.22	CONSTRUCTION ENTRANCE	SY	900.000
0001	210.3312	REMOVAL AND DISPOSAL OF BOND BREAKER/FILLER ACM (BV14	SF	140.000
0001	304.11000008	SUBBASE COURSE (MODIFIED)	CY	2560.000
0001	402.017902	TRUE & LEVELING F9, SUPERPAVE HMA, 70 SERIES COMPACTI	TON	420.000
0001	402.017912	PLANT PRODUCTION QUALITY ADJUSTMENT TO 402.017902	QU	21.000
0001	402.126102	12.5 F1 TOP COURSE HMA, 60 SERIES COMPACTION	TON	3500.000
0001	402.126112	PLANT PRODUCTION QUALITY ADJUSTMENT TO 402.126102	QU	175.000
0001	402.126122	PAVEMENT DENSITY QUALITY ADJUSTMENT TO 402.126102	QU	1.000
0001	402.126152	TEST SECTION ADJUSTMENT TO 402.126102	QU	200.000
0001	402.256902	25 F9 BINDER COURSE HMA, 60 SERIES COMPACTION	TON	50.000
0001	402.256912	PLANT PRODUCTION QUALITY ADJUSTMENT TO 402.256902	QU	3.000
0001	402.256922	PAVEMENT DENSITY QUALITY ADJUSTMENT TO 402.256902	QU	1.000
0001	402.256952	TEST SECTION ADJUSTMENT TO 402.256902	QU	200.000
0001	404.01790108	TRUE & LEVELING F9, SUPERPAVE WMA, 70 SERIES COMPACTI	TON	6600.000
0001	404.01791108	PLANT PRODUCTION QUALITY ADJUSTMENT TO 404.01790108	QU	330.000
0001	407.0101	TACK COAT	GAL	1700.000
0001	490.30	MISCELLANEOUS COLD MILLING OF BITUMINOUS CONCRETE	SY	1900.000
0001	520.50140008	SAW CUTTING, ASPHALT PAVEMENT, ASPHALT SURFACE COURSE	LF	4700.000
0001	551.60000017	FURNISHING EQUIPMENT FOR INSTALLING DRILLED SHAFTS	LS	1.000



PAGE: 3  
DATE: 08/30/2012

QUANTITY SHEET SUMMARY FOR PROPOSAL

CONTRACT ID: D262100

PROJECT(S): 806210

CONTRACTOR :

SEC NUM	ITEM NUMBER	DESCRIPTION	UNIT	QUANTITY
0001	551.96000017	CROSSHOLE SONIC LOGGING (CSL) OF DRILLED SHAFTS	EACH	8.000
0001	551.99495508	DRILLED SHAFTS	LF	271.000
0001	552.16	EXCAVATION PROTECTION SYSTEM	SF	5300.000
0001	554.42	FILL TYPE RETAINING WALL (GREATER THAN 12FT. - 18FT.)	SF	1521.000
0001	554.43	FILL TYPE RETAINING WALL (GREATER THAN 18FT. - 24FT.)	SF	1090.000
0001	554.53	FILL TYPE RETAINING WALL AESTHETIC TREATMENT - OTHER;	SF	2610.000
0001	555.0105	CONCRETE FOR STRUCTURES, CLASS A	CY	17.000
0001	555.04400008	CONCRETE FOR STRUCTURES DESIGNATED BY COMPRESSIVE STR	CY	388.000
0001	555.09	CONCRETE FOR STRUCTURES, CLASS HP	CY	128.000
0001	556.0201	UNCOATED BAR REINFORCEMENT FOR CONCRETE STRUCTURES	LB	6192.000
0001	556.0202	EPOXY-COATED BAR REINFORCEMENT FOR STRUCTURES	LB	91639.000
0001	556.0205	STAINLESS STEEL BAR REINFORCEMENT FOR STRUCTURES	LB	1698.000
0001	557.20000008	PRECAST CONCRETE SLEEPER SLAB	LF	236.000
0001	557.21010016	FIELD CAST JOINTS BETWEEN PRECAST CONCRETEUNITS	LF	1434.000
0001	557.64040108	PRECAST CONCRETE APPROACH SLAB, TYPE 1	SF	5094.000
0001	557.64040208	PRECAST CONCRETE APPROACH SLAB, TYPE 2	SF	2118.000
0001	563.00010108	NORTHEAST EXTREME TEE - NEXT BEAM TYPE D	LF	634.000
0001	563.00010208	NORTHEAST EXTREME TEE - NEXT BEAM TYPE D	LF	318.000
0001	563.11000008	PRECAST END DIAPHRAGM	LF	228.000
0001	565.14210008	NON-GUIDED POLYTETRAFLUOROETHYLENE (PTFE)SLIDING BEAR	EACH	48.000
0001	565.1922	TYPE E.L. BEARING (56 TO 111 KIPS)	EACH	48.000

PAGE: 4  
DATE: 08/30/2012

QUANTITY SHEET SUMMARY FOR PROPOSAL

CONTRACT ID: D262100

PROJECT(S): 806210

CONTRACTOR :

SEC NUM	ITEM NUMBER	DESCRIPTION	UNIT	QUANTITY
0001	569.04	SINGLE SLOPE (HALF SECTION) CONCRETE BRIDGE BARRIER	LF	596.000
0001	570.01	LEAD EXPOSURE CONTROL PLAN	LS	1.000
0001	570.02	MEDICAL TESTING	DC	200.000
0001	570.03	PERSONAL EXPOSURE MONITORING SAMPLE ANALYSIS	DC	200.000
0001	570.04	DECONTAMINATION FACILITIES	CW	2.000
0001	571.03	DISPOSAL OF HAZARDOUS PAINT WASTE CONTAINING LEAD	LB	2.000
0001	580.01	REMOVAL OF STRUCTURAL CONCRETE	CY	10.000
0001	580.04	REMOVAL OF CONCRETE APPROACH SLAB	SF	1062.000
0001	585.35010008	HORIZONTAL SLIDE AND TEMPORARY SHORING	LS	1.000
0001	595.98200018	SPRAY-APPLIED, WATERPROOFING MEMBRANE	SF	16056.000
0001	603.171614	GALVANIZED STEEL END SECTIONS-PIPE (2-2/3" X 1/2" CORR EACH		2.000
0001	603.6002	REINFORCED CONCRETE PIPE CLASS III, 15 INCH DIAMETER	LF	20.000
0001	603.6003	REINFORCED CONCRETE PIPE CLASS III, 18 INCH DIAMETER	LF	20.000
0001	603.6005	REINFORCED CONCRETE PIPE CLASS III, 24 INCH DIAMETER	LF	435.000
0001	603.7302	REINFORCED CONCRETE PIPE END SECTIONS 15 INCH DIAMETER EACH		2.000
0001	603.7307	REINFORCED CONCRETE PIPE END SECTIONS 30 INCH DIAMETER EACH		1.000
0001	603.77	CONCRETE COLLARS	EACH	7.000
0001	604.070802	ALTERING DRAINAGE STRUCTURES, LEACHING BASINS AND MAN EACH		1.000
0001	604.070803	ALTERING DRAINAGE STRUCTURES, LEACHING BASINS AND MAN EACH		5.000
0001	604.300673	RECTANGULAR DRAINAGE STRUCTURE TYPE F FOR CAST IRON F LF		21.000
0001	604.301192	RECTANGULAR DRAINAGE STRUCTURE TYPE K FOR PARALLEL BA LF		12.000

PAGE: 5  
DATE: 08/30/2012

QUANTITY SHEET SUMMARY FOR PROPOSAL

CONTRACT ID: D262100 PROJECT(S): 806210

CONTRACTOR :

SEC NUM	ITEM NUMBER	DESCRIPTION	UNIT	QUANTITY
0001	604.500801	SPECIAL DRAINAGE STRUCTURE	LF	21.000
0001	604.500802	SPECIAL DRAINAGE STRUCTURE	LF	5.000
0001	605.0901	UNDERDRAIN FILTER TYPE 1	CY	150.000
0001	605.1101	UNDERDRAIN FILTER TYPE 3	CY	10.000
0001	605.1501	PERFORATED CORRUGATED POLYETHYLENE UNDERDRAIN TUBING,	LF	122.000
0001	605.1701	OPTIONAL UNDERDRAIN PIPE, 4 INCH DIAMETER	LF	11.000
0001	606.10	BOX BEAM GUIDE RAILING	LF	525.000
0001	606.1001	BOX BEAM GUIDE RAILING WITH EXTRA LONG POSTS	LF	4450.000
0001	606.120102	BOX BEAM GUIDE RAILING END ASSEMBLY, TYPE I	EACH	6.000
0001	606.120103	BOX BEAM GUIDE RAILING END ASSEMBLY, TYPE I WITH 18 F EACH		8.000
0001	606.70	REMOVING AND DISPOSING CABLE GUIDE RAILING	LF	3600.000
0001	606.71	REMOVING AND DISPOSING CORRUGATED BEAM GUIDE RAILING	LF	70.000
0001	606.73	REMOVING AND DISPOSING BOX BEAM GUIDE RAILING	LF	1300.000
0001	606.7920	REMOVING AND DISPOSING BOX BEAM GUIDE RAILING END ASS	EACH	10.000
0001	606.83	GUIDE RAIL TRANSITION CABLE TO BOX BEAM (ONE OR TWO-W	EACH	2.000
0001	606.84	GUIDE RAIL TRANSITION BOX BEAM TO CABLE (ONE WAY ONLY	EACH	3.000
0001	606.8803	TRANSITION BETWEEN BOX BEAM GUIDE RAIL AND SINGLE SLO	EACH	8.000
0001	607.3102	OPTIONAL CHAIN-LINK FENCE, TYPE I, WITH TOP TENSION W	LF	440.000
0001	607.96000008	REMOVE AND DISPOSE OF EXISTING FENCE	LF	520.000
0001	609.0401	CAST-IN-PLACE CONCRETE CURB TYPE VF150	LF	1100.000
0001	609.0403	CAST-IN-PLACE CONCRETE CURB TYPE M150	LF	45.000

PAGE: 6  
DATE: 08/30/2012

QUANTITY SHEET SUMMARY FOR PROPOSAL

CONTRACT ID: D262100

PROJECT(S): 806210

CONTRACTOR :

SEC NUM	ITEM NUMBER	DESCRIPTION	UNIT	QUANTITY
0001	610.10	COMPOST	CY	60.000
0001	610.1402	TOPSOIL - ROADSIDE	CY	600.000
0001	610.1601	TURF ESTABLISHMENT - ROADSIDE	SY	20000.000
0001	610.19	WATERING VEGETATION	MGAL	210.000
0001	610.21	MOWING	SY	44000.000
0001	619.01	BASIC WORK ZONE TRAFFIC CONTROL	LS	1.000
0001	619.04	TYPE III CONSTRUCTION BARRICADE	EACH	9.000
0001	619.0801	REMOVE EXISTING PAVEMENT MARKING STRIPES	LF	27000.000
0001	619.100102	INTERIM PAVEMENT MARKINGS, STRIPES (EPOXY PAINT)	LF	33000.000
0001	619.110205	PORTABLE, VARIABLE MESSAGE SIGN (PVMS) (LED) (NTCIP CO	EACH	10.000
0001	619.1701	TEMPORARY CONCRETE BARRIER, (UNPINNED)	LF	12240.000
0001	619.1703	TEMPORARY CONCRETE BARRIER, (PINNED)	LF	5000.000
0001	619.1802	TEMPORARY IMPACT ATTENUATOR - REDIRECTIVE (TEST LEVEL	EACH	6.000
0001	619.24	NIGHTTIME OPERATIONS	LS	1.000
0001	619.25	TRAFFIC CONTROL SUPERVISOR	MNTH	8.000
0001	619.55010108	DEDICATED POLICE SERVICES	DC	50000.000
0001	620.03	STONE FILLING (LIGHT)	CY	460.000
0001	621.03	CLEANING CLOSED DRAINAGE SYSTEMS	LF	1300.000
0001	621.04	CLEANING DRAINAGE STRUCTURES	EACH	9.000
0001	621.51000015	GRADING CLEANING AND RESHAPING EXISTING DITCHES	LF	285.000
0001	623.12000008	CRUSHED STONE (IN PLACE MEASURE) MODIFIED	CY	62.000

PAGE: 7  
DATE: 08/30/2012

QUANTITY SHEET SUMMARY FOR PROPOSAL

CONTRACT ID: D262100 PROJECT(S): 806210

CONTRACTOR :

SEC NUM	ITEM NUMBER	DESCRIPTION	UNIT	QUANTITY
0001	625.01	SURVEY OPERATIONS	LS	1.000
0001	633.11	CLEANING EXISTING PAVEMENT AND/OR SHOULDERS	SY	30000.000
0001	637.14	ENGINEER'S FIELD OFFICE - TYPE 4	MNTH	16.000
0001	637.34	OFFICE TECHNOLOGY AND SUPPLIES	DC	5000.000
0001	639.10220001	CPM (CRITICAL PATH METHOD) PROGRESS SCHEDULE - TYPE 2	LS	1.000
0001	649.01	MILLED-IN AUDIBLE ROAD DELINEATORS (MIARDS)	LF	5600.000
0001	655.0706	CAST FRAME F3, UNMOUNTABLE CURB BOX CU3 & RETICULINEG EACH		3.000
0001	655.0903	PARALLEL BAR FRAME 12 PCB & PARALLEL BAR GRATE 12 PC EACH		13.000
0001	655.1006	WELDED FRAME AND RECTANGULAR GRATE 6	EACH	1.000
0001	685.07200118	WHITE EPOXY REFLECTORIZED PAVEMENT STRIPES- 20 MILS (	LF	21000.000
0001	685.07200218	YELLOW EPOXY REFLECTORIZED PAVEMENT STRIPES- 20 MILS	LF	9500.000
0001	685.07200318	WHITE EPOXY REFLECTORIZED PAVEMENT LETTERS - 20 MILS(	EACH	12.000
0001	685.07200418	WHITE EPOXY REFLECTORIZED PAVEMENT SYMBOLS - 20 MILS	EACH	4.000
0001	688.01	WHITE PREFORMED REFLECTORIZED PAVEMENT STRIPES	LF	60.000
0001	691.03000020	TRAINING REQUIREMENTS	DC	7000.000
0001	697.03	FIELD CHANGE PAYMENT	DC	450000.000
0001	698.04	ASPHALT PRICE ADJUSTMENT	DC	13213.000
0001	698.05	FUEL PRICE ADJUSTMENT	DC	3211.000
0001	698.06	STEEL/IRON PRICE ADJUSTMENT	DC	200.000
0001	698.93940001	INCENTIVE PAYMENTS/DISINCENTIVE ASSESSMENTS /HOURLY B	LS	1.000
0001	699.040001	MOBILIZATION	LS	1.000