

Development of Prefabricated Concrete Bridge Railings

QUARTERLY PROGRESS REPORT

Updated to include progress between April 1, 2016 to June 31, 2016 Period

Submitted by

Sri Sritharan, Terry Wipf, Ashley Ecklund

Department of Civil and Environmental Engineering

Iowa State University

Ames, Iowa

**IOWA STATE
UNIVERSITY**



Submitted to Atorod

Azizinamini

Director, ABC-UTC

June 2016

ABC-UTC
Quarterly Research Progress Report
Title: Development of Prefabricated Concrete Bridge Railings
June, 2016

A. DESCRIPTION OF RESEARCH PROJECT

Many organizations are promoting and utilizing Accelerated Bridge Construction (ABC) practices to reduce traffic impacts and to reduce societal costs. One of the most common means to achieve ABC is to utilize prefabricated elements which are brought together, on-site, to construct the in-place bridge. The purpose of this research is to begin the process of developing crash-tested prefabricated concrete bridge railings that have durable anchorage details.

The developed prefabricated bridge railings must be attached to a bridge superstructure with durable connections that satisfy the MASH 2009 Specification. Needed anchorage systems include details that connect the prefabricated bridge railing to the bridge deck and details that connect one prefabricated bridge railing to an adjacent prefabricated bridge railing. The end products of this research will be crash-tested prefabricated bridge railings with recommended durable anchorage systems and details that meet design test level TL-4 in accordance with MASH and LRFD Bridge Design Specifications.

A.1. PROBLEM STATEMENT

With the significant interest in ABC there has been valuable research in many important and varied areas. However, one area that has not yet received notable research is in the area of prefabricated, crash-tested barrier rails. As a result, ABC projects to date have tended to rely upon systems that utilized crash-tested systems integrated into other, larger prefabricated elements. Although this has proved sufficient while ABC has been in its relative infancy, there is a critical need to develop prefabricated bridge railings that have been crash-tested.

A.2. RESEARCH APPROACH AND METHODS

To achieve the complete objective of developing crash-tested prefabricated bridge railings, a two-step process will be required. In brief, the two steps will be: (1) development and laboratory testing of prototype concepts and (2) crash-testing of promising concepts. The work completed here will be restricted to item (1). It should be pointed out that a plan for implementing (2) has already been put into motion.

A.3. DESCRIPTION OF TASKS TO BE COMPLETED IN RESEARCH PROJECT

Following are description of tasks as described in the proposal and their current status.

Task 1: Conduct a national literature search to review all bridge railing (cast-in-place and prefabricated railings) designs and details including anchorage systems that have been crash tested for use on the national highway system by state DOTs and private agencies. Survey state DOTs to determine their needs related to prefabricated bridge railing. Information from research projects through the NCHRP, SHRP2, FHWA, and other national, state, and pooled-fund sponsored research will be reviewed as part of this task. Railing shapes that meet the current MASH requirements will be considered I this task and subsequent tasks. As part of this search, consideration will also be given to the different types of elements used in prefabricated bridges.

There are a few different permanent precast concrete barriers that have been developed with different anchoring methods. Precast barriers are generally categorized by the shape of their profile. The New Jersey shape, the F-shape and the single slope are the three most commonly used precast concrete barrier profiles in the United States.

Common methods for anchoring precast concrete barriers to bridge decks include through-deck bolts and adhesive anchors. With the through-deck anchoring method, a hole is drilled thorough the entire bridge deck and a bolt is inserted through both the barrier and the deck. It is secured with heavy washers and nuts on both ends of the steel bolt. One issue with this design is getting access to the underside of the bridge to secure the nut. Another issue is weathering of the exposed connection. Figure 1 shows a typical anchoring detail for the through-deck configuration.

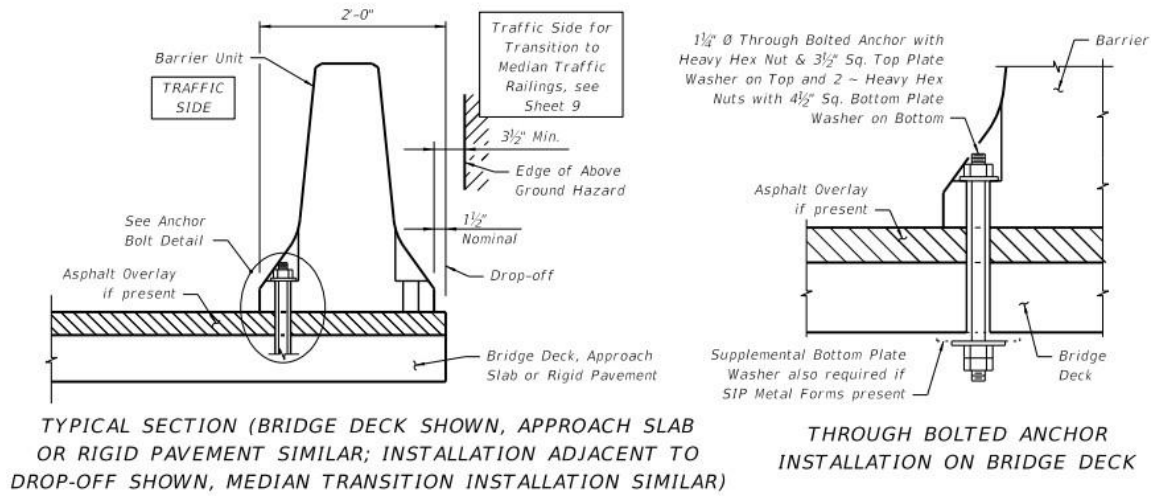

Figure 1 Through-Deck Bolting Detail (Source: FL DOT 414)

A different way of connecting a barrier with the through-deck method is by pretensioned rods that are inserted all the way through the wall and the deck slab. They are then anchored to the bridge deck by end plates, washer, and nuts. An example of this can be seen in Figure 2.

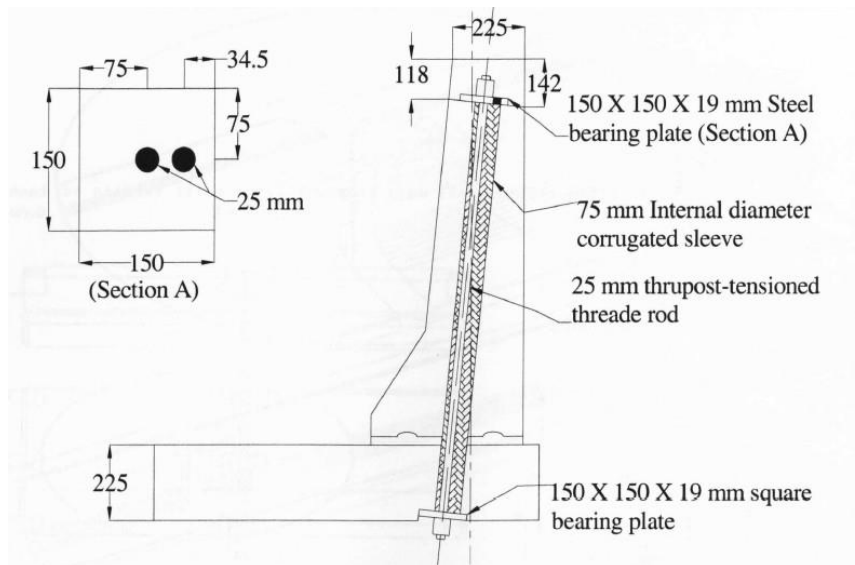

Figure 2 Barrier to deck Slab Connection (Source: Patel Dissertation, Fig 3.1)

Another precast concrete barrier anchoring technique that is used is an adhesive-bonded anchor. This method is completed by drilling a hole into the bridge deck and then inserted the threaded bolt through the barrier and into the deck. The bolt is then secured with an adhesive. This method can be seen in Figure 3. One issue with this anchoring method is the strength of the adhesive used.

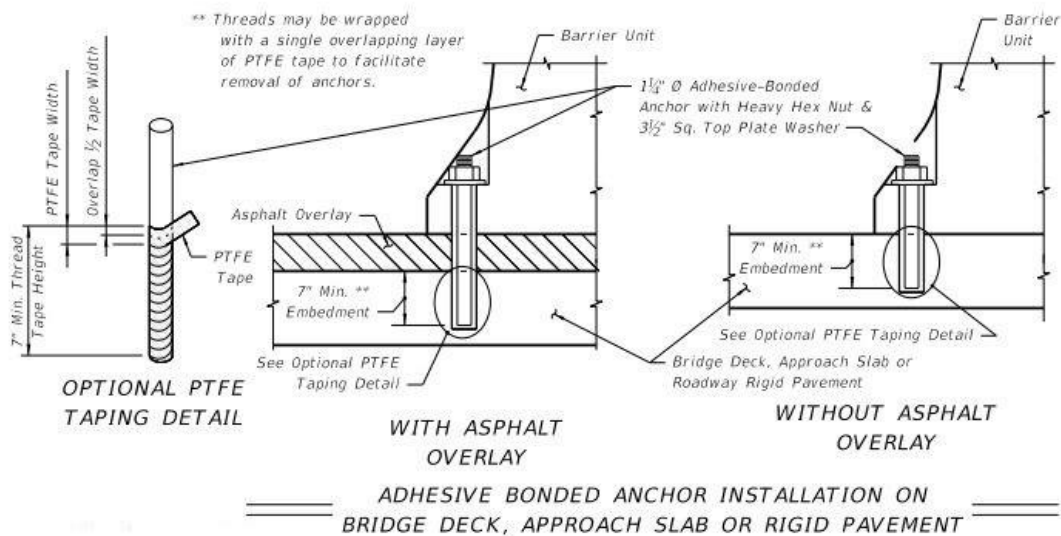

Figure 3 Adhesive-bonded Anchor Detail (Source: FL DOT 414)

A precast barrier wall system similar to the adhesive anchored connection is engineering and patented by Clampcrete. It has been crash tested and approved for use. It is connected to the bridge deck by polyester resin anchors that are drilled into the bridge deck. This system is shown in Figure 4.

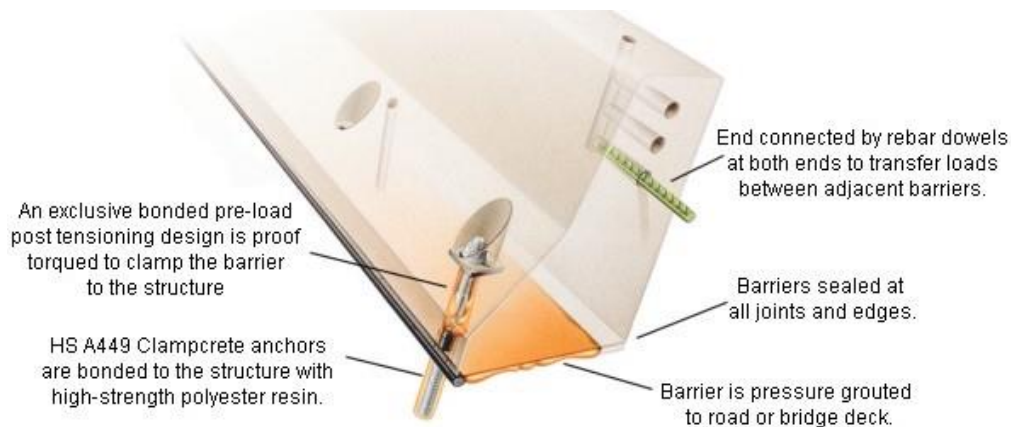

Figure 4 Clampcrete Barrier System (Source: clampcrete.com)

Task 2: Based upon the results of the literature search, the research team will develop conceptual prefabricated railings with associated anchorage systems and details. Although the ultimate goal is to develop a system that can be adopted for multiple railing shapes, only one shape will be utilized in the experimental program to be conducted in Task 3. At a minimum, the concepts will consist of details for connecting the rails to the deck and for connecting adjacent rails. It is

anticipated that a minimum of three different rail-to-deck and three different rail-to-rail systems will be conceptualized.

For this project, based on a nationally conducted survey, an F-shape profile was chosen. When connecting the precast concrete barrier to the bridge deck, two connection concepts were designed. The first design concept includes a u-shaped stainless steel bar that is inserted through the bottom of the bridge deck and into the barrier segment. The u-shaped rebar will then be secured with 10 ksi, non-shrink, fiber grout. This concept can be seen in Figure 5.

PRECAST CONCRETE BARRIER
DETAILS OF CONNECTION USING U-BAR

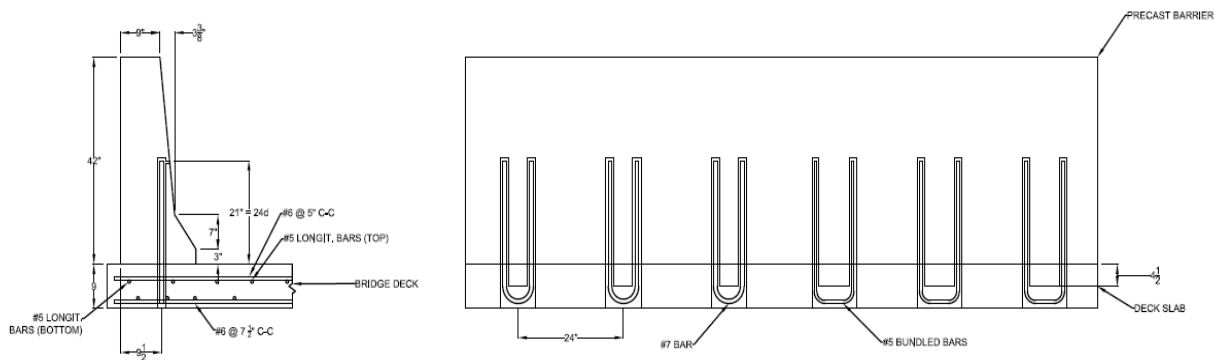

Figure 5 Details of Connection Using U-Bar

Another concept consists of an inclined stainless steel bar and bar splicer. The bar splicer will be precast into the bridge deck. Then the stainless steel bar will be inserted into the barrier segment and threaded into the bar splicer. This connection will also be sealed with grout and is shown in Figure 6. Figure 7 shows a photo of the bar splicer that will be used.

PRECAST CONCRETE BARRIER
DETAILS OF CONNECTION USING STAINLESS STEEL BAR
WITH THREADED END AND BAR SPLICER

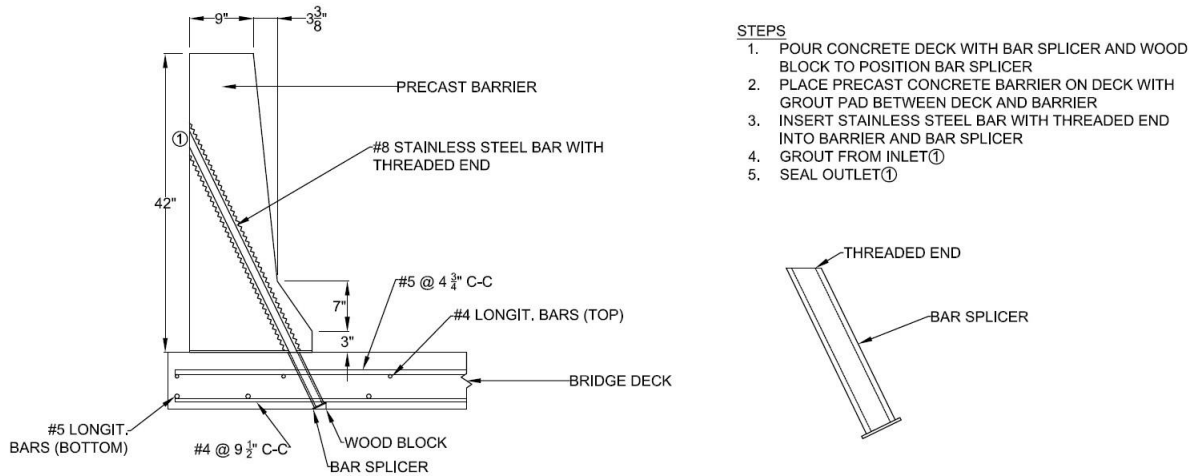

Figure 6 Details of Connection using Stainless Steel Bar with Threaded End and Bar Splicer



Figure 7 Bar Splicer

The barrier-to-barrier connection detail includes four headed rods precast into the end of the barrier segment. The headed rods are inserted into a pocket in the adjacent barrier. Figure 8 shows this detail. Also, more detailed drawings of the barrier test concepts are included at the end of this report.

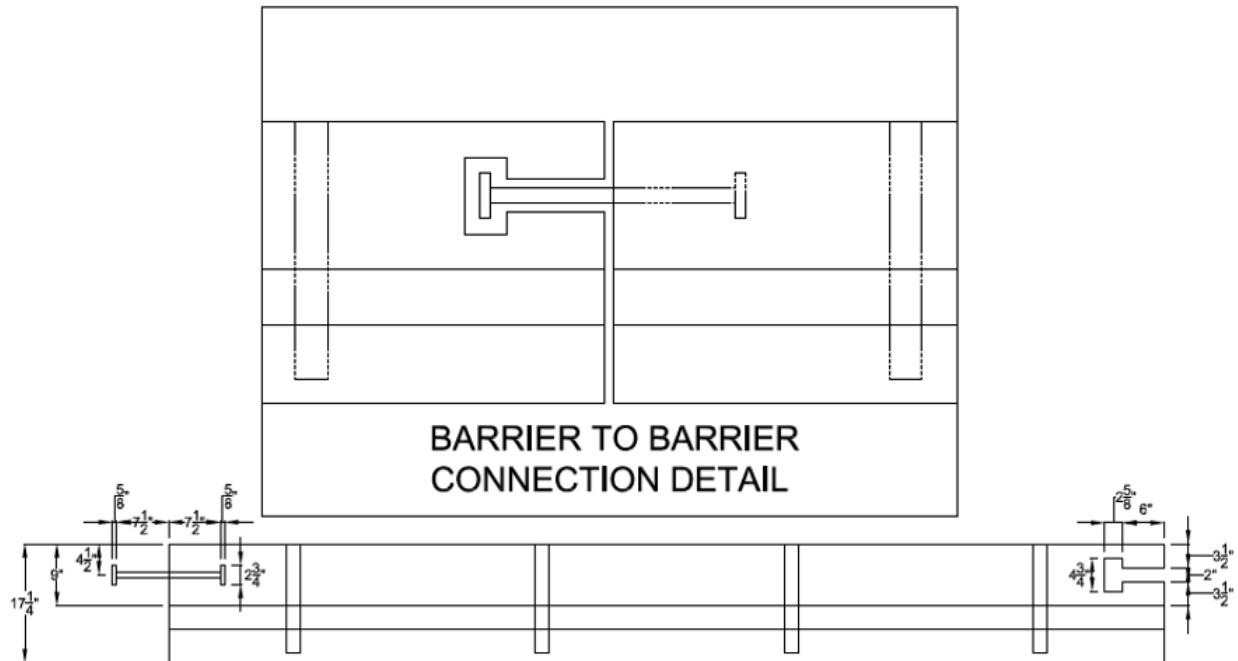

Figure 8 Barrier Connection Detail

The test level 4 design load of 54 kips was used to design the connections. To limit the damage to the barrier and bridge deck, the connections were designed to allow the connections to fail instead of the barrier and bridge deck.

Task 3: The two barrier connection systems shown above have been tested in the laboratory with quasi-static testing. The loads were applied cyclically using a hydraulic actuator. The systems will be evaluated based upon how they impact their individual strengths and how they impacted the performance of the deck overhangs used to support the railing. The actuator that will be used in shown in Figure 9.



Figure 9 Hydraulic Actuator

The barrier segments were tested individually to test the barrier to deck connection. Then they were connected and tested again. The force was applied at the joint to measure the force distribution. A ponding test will also be conducted on the connections to test for durability. A schematic drawing of the lab test set-up can be seen in Figures 10 and 11.

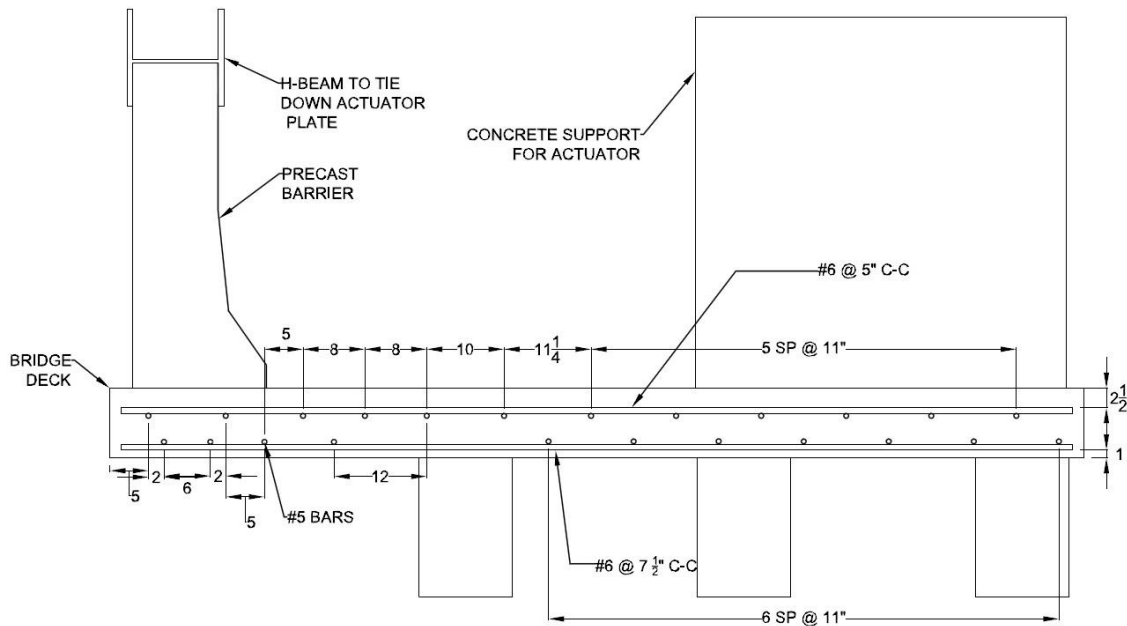

Figure 10 Lab Test Set-up

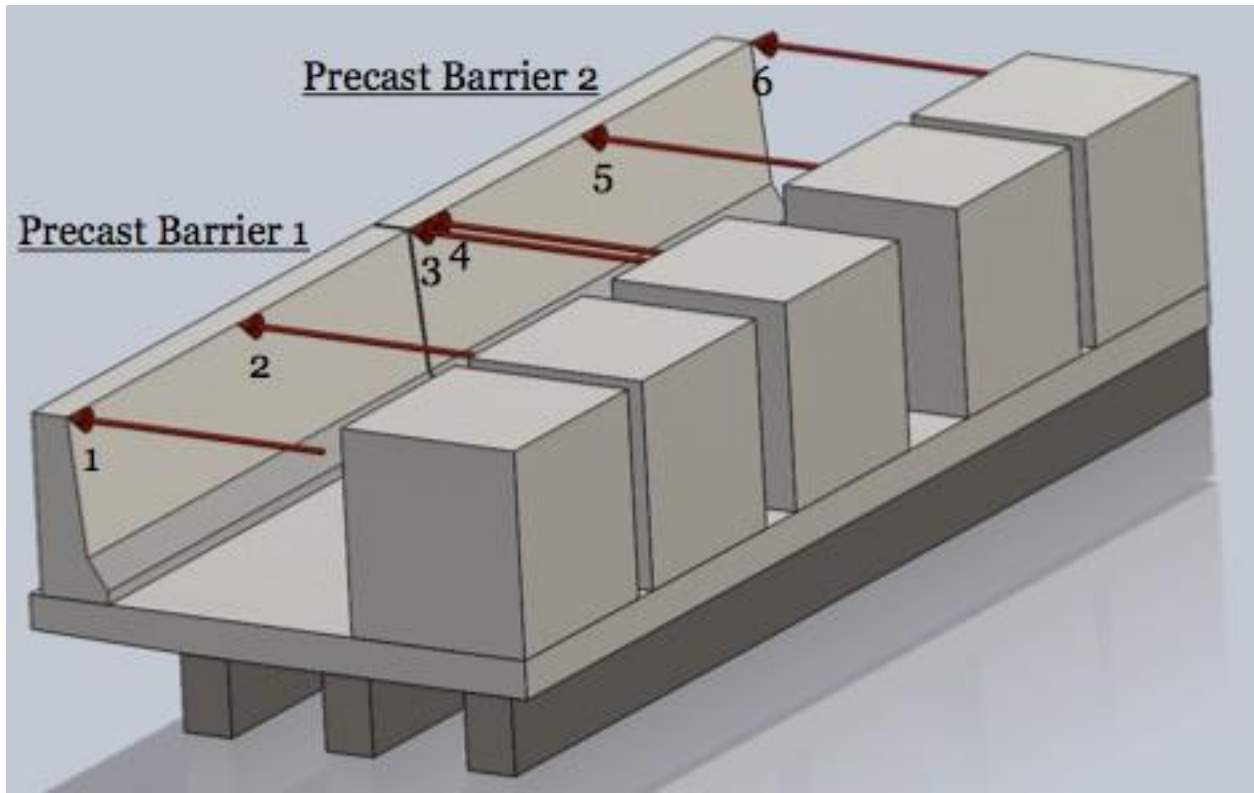

Figure 11 3D Model of Lab Set-up with Applied Load Locations

Three concrete beams support the deck slab. The deck slab will have an overhang of 3.5 feet. The hydraulic actuator was mounted onto the concrete block to apply load along the precast barrier segments. The concrete blocks are anchored into the lab floor. The concrete beams and the formwork for the suspended deck slab are shown in Figure 12.



Figure 12 Concrete Beams with Deck Slab Formwork

The construction of the barrier rails was fabricated by a precast plant in Omaha. They were delivered to the Iowa State Lab February of 2016. Images of the precast construction are shown in Figure 13.



Figure 13 Precast Barrier Fabrication

The construction of the deck slab and the loading block were done in the Iowa State University Structures Lab. The following images (Figures 14-16) display the progress in the lab.



Figure 14 Inclined Bar Connection in Bridge Deck



Figure 15 Pockets for U-bar Connection in Bridge Deck



Figure 16 Bridge Deck Prior to Concrete Pour

Laboratory testing began March of 2016. The first laboratory test was conducted on the precast barrier with the inclined rod connection, PBI. The loading block and actuator were set up to apply loads to the center of PBI. The test setup is shown in Figure 17. The push load was applied incrementally up to 54 kips. It was applied in six kip increments.



Figure 17 Test 1 (PBI Middle) Setup

The barrier performed as expected. Cracks developed along the deck around 18 kips. It wasn't until the loading reached 48 kips that diagonal, hairline cracks began to form on the barrier near the barrier-to-barrier interface. The maximum deflection of the barrier was measured at 0.807 inches. Photos of the barrier performance can be seen in Figures 18 and 19.

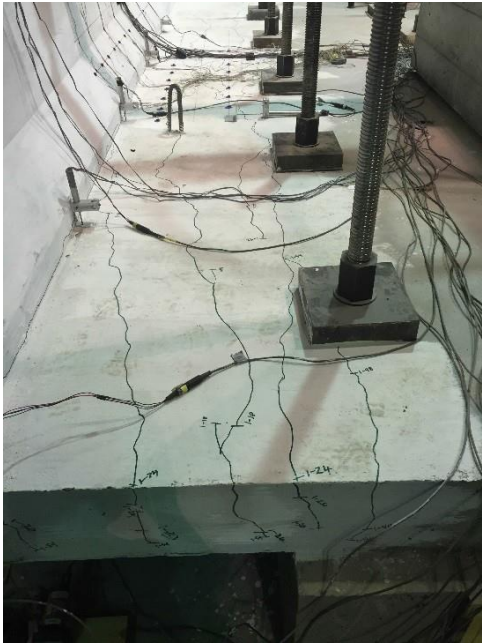

Figure 18 Test 1 (PBI Middle) Deck Cracks

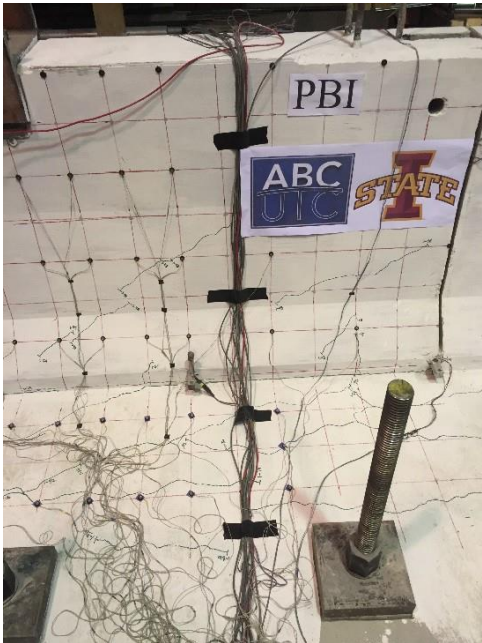

Figure 19 Test 1 (PBI Middle) Barrier Cracks

The second test was conducted on the precast barrier with the u-bar connections. The loading block and actuator were set up to apply loads to 3.5 feet in the center of the barrier. The purpose of this test was to examine the connection between the precast barrier and the bridge deck. The connection consisted of a u-shaped rebar inserted through the bridge deck into the barrier. The loading was planned to be applied up to 54 kips in 6 kip increments. After a few increments the barrier stopped holding the load. The barrier was loaded up to 36 kips in 6 kip intervals. The first three intervals, up to 18 kips, performed very similar to Test 1. New deck cracking began around 18 kips. At this point the barrier was deflected 0.164 inches. At 24 kips, a crack became visible along the entire length of the grout pad between the barrier and the bridge deck, see Figure 20. The existing cracks continued to widen up until about 36 kips. Around 36 kips some softening was observed and the barrier was no longer holding the load. The barrier deflection reading after the maximum load was 0.8 inches.

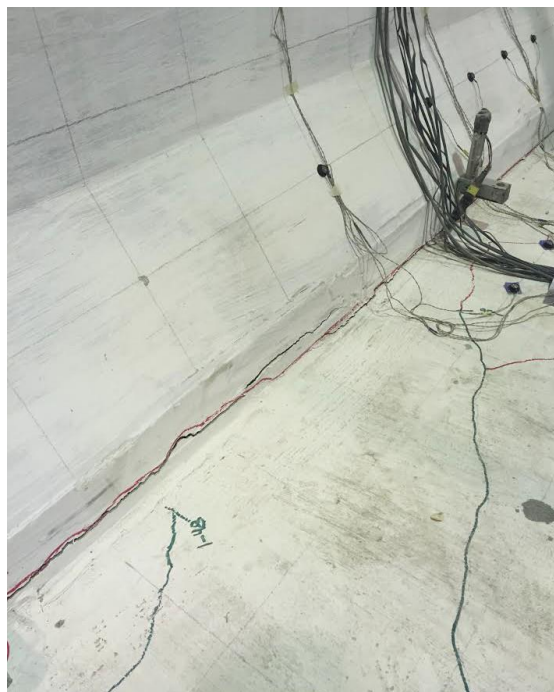

Figure 20 Crack at barrier and deck interface during Test 2

The third test was conducted on the precast barrier system between the two barriers. The loading block and actuator were set up to apply loads to 3.5 feet in the center of the entire test unit. The purpose of this test was to examine the connection between the precast barriers. Before testing could begin, the connection between the barriers was grouted. In the early stages of testing, no

new cracks developed but old cracks began to open up. Around 30 kips a new crack appeared on the side of the bridge deck on the PBI side. It wasn't until 48 kips when cracks began to show on the barrier with the inclined connection. The cracks were diagonal cracks going in the opposite direction as the Test 1 cracks, see Figure 21. The center was able to hold a load up to 60 kips before it started dropping. The load was then released. The cracks along the grout between the barriers and the deck remained. The crack on the inclined barrier side of the grout pad was measured at a width of 0.005 inches. The u-bar side was measured at a width of 0.07 inches. The majority of the cracks appeared on the inclined connection side, no cracks appeared on the u-bar connection barrier. The inclined connection barrier was most likely taking all the load.

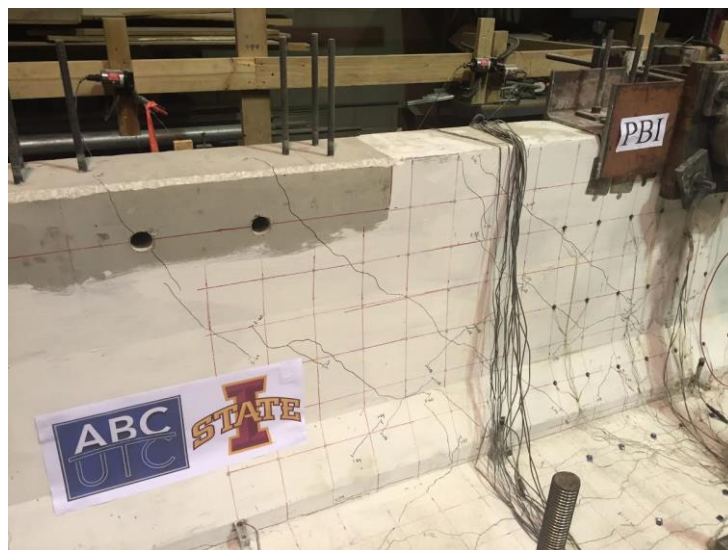

Figure 21 Diagonal cracks during Test 3

For Test 4, the loading beam was placed to the inclined connection side of the barrier-to-barrier connection. The center of the load was about three feet from the barrier-to-barrier connection. The purpose of the test was to observe the force distribution about the barrier-to-barrier connection and to fail the center connection. Before this test was performed, a beam was placed on the u-bar side to brace the barrier and keep it from deflecting. This brace beam can be seen in Figure 22.



Figure 22 Beam used to brace the u-bar connected barrier during Test 4

Hairline cracks didn't form on the grout between the barrier until 24 kips was applied. Other previous cracks just extended and opened up. At 48 kips, a crack developed on the front face of the grout between the barriers. A crack formed on the back of the barrier-to-barrier grout at 54 kips. This crack started at the bottom of the barrier. As the loads were increased, cracks continued to extend. At 72 kips, new cracks developed on the top of the barrier-to-barrier grout. The load was increased up to 81 kips before it started dropping. The test continued until the deflection was measured at 1.5 inches. Large cracks developed along the barrier under the loading beam, see Figure 23, and the barrier-to-barrier grout broke all the way along the top to the back, see Figure 24.



Figure 23 Cracking on barrier due to loading during Test 4

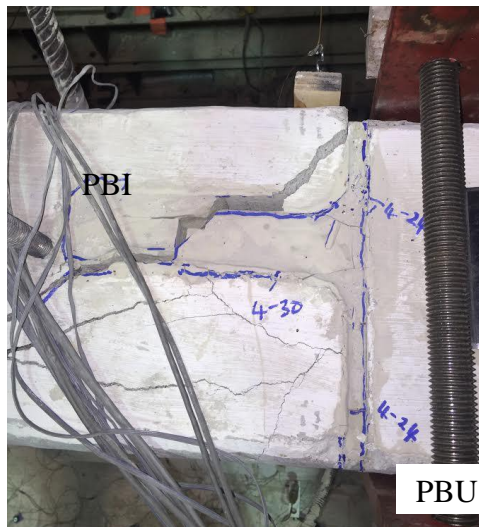

Figure 24 Failure pattern of barrier-to-barrier grout after Test 4

Conclusions drawn from this study are as follows. The two precast barrier systems did not have any construction challenges in the assembly. The barrier system connections were assembled as planned without any challenges. The construction of the inclined connection required minimal access to install the connection reinforcement. The u-bar connection required access from under the bridge overhang to install the u-shaped connection reinforcement. A summary of the loading and deflection of the barrier for each test is indicated in Table 2.

Table 1 Testing Summary

Test	Maximum Load	Maximum Displacement
PBI Middle (Test 1)	Push = 54 kips Pull = 2 kips	0.807 inches Final resting position = 0.26
PBU Middle (Test 2)	Push = 36 kips Pull = 4 kips	0.8 inches Final resting position = 0.3
Center – Attached (Test 3)	Push = 60 kips	0.56 inches Final resting position = 0.17
Off Center, PBI (Test 4)	Push = 81 kips	Loaded until 1.5 inches

When an isolated unit of the inclined connection was subjected to test level 4 loading, it performed satisfactory, which was expected. The barrier, deck and barrier to deck connection performed well with no elastic strains developing in the deck reinforcement. The deck began to

crack as the loading approached 18 kips. Hairline diagonal cracks were witnessed on the inclined connection barrier as the loading reached 48 kips. The cracking that developed on the deck was uniform and extended beyond the expected 45° force dispersion. As the applied load reached 54 kips, the top of the barrier experienced a total top lateral displacement of 0.81 inches.

During the isolated testing of the u-bar connection, Test 2, the barrier was able to resist 36 kips without experiencing significant rotations. Larger rotation occurred from this point onward with localized deformation concentrated at the bottom of the barrier. This was suspected to be due to insufficient development length of the top deck reinforcement.

The test conducted on the barrier-to-barrier connection, Test 3, also performed as expected. The barrier system was loaded up to 60 kips with the inclined connection supporting the majority of the load. The strain experienced in the inclined deck connections was significantly more than the strain experienced in the u-bar deck connections. Test 4 included loading on the inclined side of the barrier to barrier connection and demonstrated the force distribution about the barrier to barrier connection and the failure pattern of the connection.

In the design process, the impact force was expected to disperse at a 45° angle from the region where the load was applied. Results from this experiment demonstrated that the actual distribution angle was lower than 45°. Therefore, more of the barrier and bridge deck were engaged in resisting the load. The deck-cracking pattern observed during testing showed that engagement of the deck reinforcement was farther than the expected result. The strain experienced by the deck reinforcement was fairly uniform along the 45° dispersion indicating that reinforcement can be reduced in this area by at least 30%.

The inclined reinforcement connection proved to be sufficient for a Test Level 4 barrier systems. The u-bar connection will be revised and appropriate details will be presented as part of this project.

Task 4: A final report will be developed that documents the entire project with a special emphasis on the results of Task 3. More importantly, recommendations for rails on which full-

scale crash testing should be conducted will be made. If appropriate, the research team will make recommendations for potential modifications to the details.

The final report will be submitted December of 2016.

A.4. EXPECTED RESULTS AND SPECIFIC DELIVERABLES

The primary deliverable resulting from this work will be barrier rail recommended to undergo full-scale crash testing.

References:

- Artimovich, Nicholas. "Concrete Barriers." – *FHWA Safety Program*. Web. Feb. 2014.
- AASHTO LRFD Bridge Design Specifications, Customary U.S. Units*. Washington, DC: American Association of State Highway and Transportation Officials, 2012. Print.
- Artimovich, Nicholas. "Concrete Barriers." – *FHWA Safety Program*. Web. Feb. 2014.
- Barker, R. M., and Jay Alan. Puckett. *Design of Highway Bridges: An LRFD Approach*. Hoboken, NJ: John Wiley & Sons, 2007. Print.
- "Bridge Railings – Safety | Federal Highway Administration." *Bridge Railings – Safety | Federal Highway Administration*. N.p., 30 Sept. 2015. Web. Oct. 2015.
- Clampcrete Construction Systems*. Clampcrete, Web. Feb. 2014.
- Florida DOT Design Standards*. Index No. 414. 2006.
- Manual for Assessing Safety Hardware*. Washington, DC: Association, 2009. Print.
- Patel, Gaurang, Khaled Sennah, Hossein Azimi, Clifford Lam, and Reza Kianoush. "Development of a Precast Concrete Barrier Wall System for Bridge Decks." *PCI Journal* (2014).
- Roadside Design Guide*. Washington, D.C.: American Association of State Highway and Transportation Officials, 2011. Print.
- Rosenbaugh, Scott K., Ronald K. Faller, Robert W. Bielenberg, Dean L. Sicking, and John D. Reid. *Phase I Development of an Aesthetic, Precast Concrete Bridge Rail*. Rep. Lincoln, NE: Nebraska Department of Roads, 2012. Print.